



OVERVIEW

Please provide feedback on this document via email - info@thonk.co.uk

This document provides key information for building the 258J Oscillator component kit as available from Thonk. These notes are not written for complete beginners but a more detailed build document will follow eventually.

This BOM will work with any revision of the J3RK 258J board, however the images in this document are specific to the boards which are marked REV 1-28-2013.

Older PCB revisions did not have revisions marked and some required modification to work correctly. Refer to the thread linked below to determine which board you have – In particular there was a run of boards in late 2012 which required a trace being cut and a jumper wire adding – <http://www.muffwiggler.com/forum/viewtopic.php?t=66072&start=142>

DOCUMENT HISTORY

v1.0 – March 6th 2013

v1.1 – May 19th 2013

- Wiring diagram now specific to Clarke68 euro panel.
- Ground output was titled incorrectly in the 'Test Wiring' section.



For most experienced DIYers this image below should provide **most** of the information about orientation you should require, the following pages provide more detail. Note: I haven't provided the power connection header in the kit.

Note that this image is of a board which has been **hardwired to a sawtooth output waveform**. It is possible to make this switchable between sawtooth and square and I have provided all the resistors required for this. Switching details are provided at the end of the document.

TAKE CARE! THE ORIENTATION OF THE SILVER NTE129 IN PARTICULAR NEEDS TO BE NOTED AS THE PIN ORIENTATION IS DIFFERENT ON THE PCB AND THE PACKAGE. SEE PAGE 7

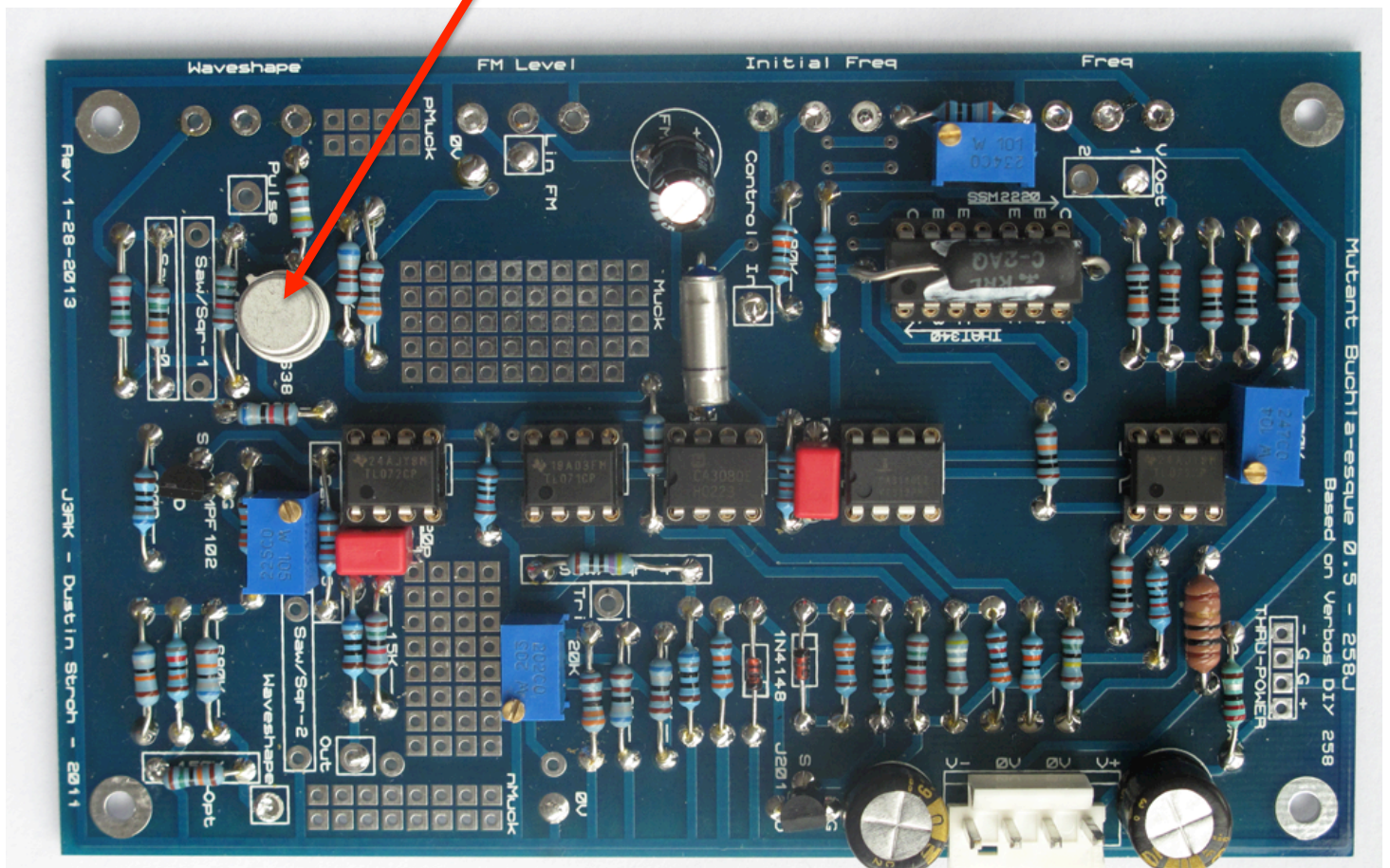

This PCB is not just for show! you can hear this very board in action here <https://soundcloud.com/thonksynth/thonk-258j-pcb-parts-kit-quick>



BILL OF MATERIALS

This is an illustrated BOM which is written in the order that I suggest you build in. As this PCB is designed to be used with different component options there are some parts which end up more tightly packed than others. By following this BOM in this order I will highlight where you need to take care to allow parts to fit well.

BAG A

MATCHED COMPONENTS FOR SINE SHAPER

Note: All resistors are 0.25W apart from the 10R and 2.2R resistors which as specified are provided as 0.5W and 0.6W respectively.

We will start by identifying the three smaller ziplock bags in **BAG A** which are marked as having **pairs of matched components**. Note that there are also bags of resistors of the same value which **ARE NOT MATCHED**. Leave these until later.

| Component | # in kit | Notes |
|-------------------------|----------|--|
| 1N4148 Diodes (Matched) | 2 | See image below for orientation Can be damaged with excessive heat |
| 330K 1% (matched) | 2 | See image below for orientation |
| 680R 1% (matched) | 2 | See image below for orientation |

The 6 components for the sine shaper

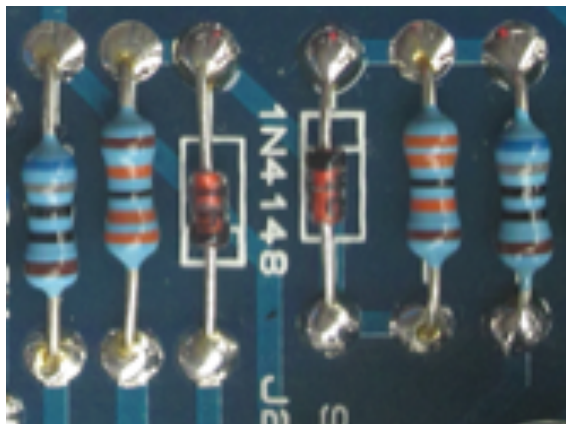



RESISTORS FOR SWITCH AND OPTIONAL 150K RESISTOR

You should next take the following bags are reserve one of each for the sawtooth/square selection which we will approach after everything else is done.

| Component | # in kit | Notes |
|-----------|----------|--|
| 150K 1% | 2 | INCLUDES 1 RESISTOR FOR SWITCH #0 AND ONE OPTIONAL RESISTOR |
| 330K 1% | 2 | INCLUDES 1 RESISTOR FOR SWITCH #1 Make sure you leave enough room to seat the 1M trimmer. |
| 680K 1% | 3 | INCLUDES 1 RESISTOR FOR SWITCH #2 |
| 820K 1% | 2 | INCLUDES 1 RESISTOR FOR SWITCH #3 |

The other 150K resistor is optional and is concerned with the range of voltage required for the waveshape modulation input. In a Eurorack system for example installing this resistor will provide a good compatible modulation range. In other systems you may want to leave it out until you have tested if your CV modulation is working across the entire range. If you don't install it it's fine to leave this space on the PCB empty, it doesn't need a jumper wire.

Then the following resistors are reserved entirely for the Sawtooth/Square selection – put them also to one side for now.

| Component | # in kit | Notes |
|-----------|----------|---------------|
| 2.2K | 1 | For SWITCH #4 |
| 470R | 1 | For SWITCH #4 |



REMAINING RESISTORS

The remaining resistors can all now be soldered to the positions as indicated on the PCB.

| Component | # in kit | Notes |
|-----------------|----------|--|
| 1.5M 1% | 1 | |
| 390K 1% | 1 | |
| 180K 1% | 1 | |
| 100K 1% | 6 | |
| 68K 1% | 2 | |
| 33K 1% | 1 | |
| 15K 1% | 4 | |
| 10K 1% | 4 | Loose - not bagged Take care to allow the 100pF capacitor to fit between the 10k resistor and IC sockets. |
| 6.81K 1% | 1 | |
| 6.8K 1% | 2 | |
| 4.99K 1% | 1 | |
| 3.3K 1% | 2 | |
| 2.49K 1% | 1 | |
| 1.8K 1% | 1 | |
| 680R 1% | 2 | |
| 390R 1% | 1 | Take care to leave enough room for the 100R trimmer |
| 10R (0.5 Watt) | 1 | |
| 2.2R (0.6 Watt) | 1 | Bag is not marked as (0.6 Watt, but it is) |



IC SOCKETS

Next you should solder all 6 IC sockets, taking care to align the notch in one end of the socket with the marking on the silkscreen. Note that the notch on the 14 pin socket should be aligned in the THAT340 direction.

| Component | # in kit | Notes |
|------------------|----------|-----------|
| 8 Pin IC Socket | 5 | |
| 14 Pin IC Socket | 1 | See image |

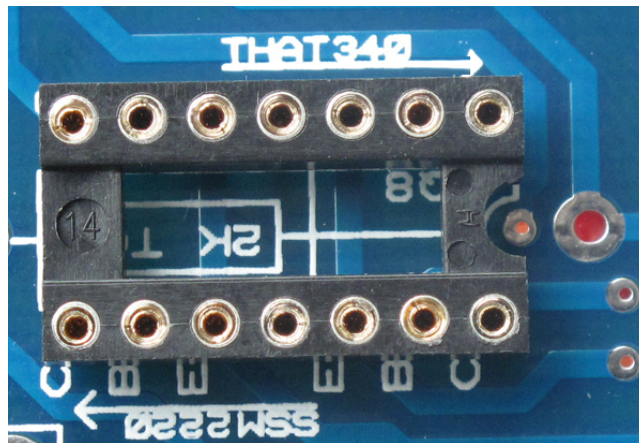

POLYSTYRENE AND POLYPROPYLENE CAPACITORS

| Component | # in kit | Notes |
|-----------------------|----------|--|
| 1 .0047uF Polystyrene | 1 | The Capacitor will be raised up from the board slightly, take care that its leads don't touch the body of the capacitor. |
| 1 220pF Wima | 1 | Tight fit, bent slightly to the side. |
| 1 100pF Wima | 1 | Tight fit, can happily sit above 10k resistor if necessary. |

Note these images below are from a fully completed board.

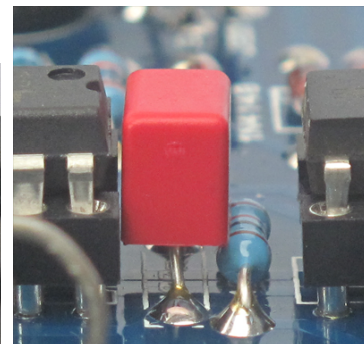
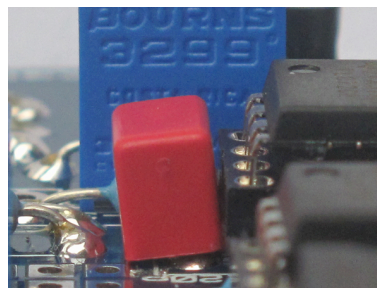
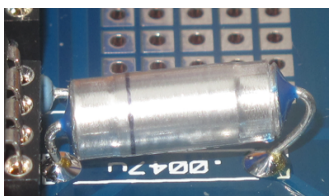



TRANSISTORS

| Component | # in kit | Notes |
|-----------|----------|---------------------------------------|
| 1 MPF102 | 1 | |
| 1 J201 | 1 | |
| 1 NTE 129 | 1 | READ BELOW! PCB label = 2N3638 |

The MPF102 and J201 are installed with the text on the component facing the D + G holes marked on the PCB and the curved back of the component facing the S pin. The S pin is bent slightly backwards so the three pins form a 'tripod' shape.

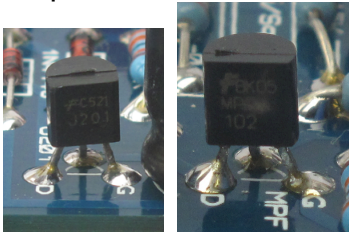

The NTE129 is one of many available high quality replacements for the obsolete 2N3638 as marked on the board.

To solder the NTE129 you need to bend the central 'B' pin back between the 'E' and 'C' pins.

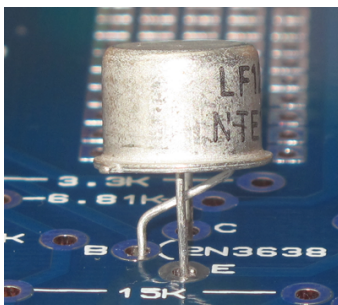

The image to the left shows you how you should insert the transistor once the middle 'B' pin is bent back.

You should position the NTE129 so it is positioned just above the resistor height and the 'B' leg should **NOT** contact the body. Refer back to page 2 for an overhead shot showing the orientation tag on the transistor body.



TRIMMERS

Next you can install the four blue Bourns trimmers. Look to the image on page 2 for suitable orientations.

| Component | # in kit | Notes |
|-------------|----------|-------|
| 1 100K Trim | 1 | |
| 1 100R Trim | 1 | |
| 1 1M Trim | 1 | |
| 1 20K Trim | 1 | |

ELECTROLYTIC CAPACITORS

Next you can install the three Electro Caps. Remember, the lead with the long lead goes to the hole marked + on the PCB. The negative side of the cap is marked with a contrasting thick coloured line on the body of the cap. Look to the image on page 2 for confirmation of orientation.

| Component | # in kit | Notes |
|----------------------|----------|-------|
| 1 15uF Electrolytic | 1 | |
| 2 100uF Electrolytic | 2 | |



SWITCH RESISTORS

There are five resistor positions on the board which determine whether the main waveshape output travels from either Sine -> Sawtooth or Sine -> Squarewave. This is achieved purely by one of two sets of resistors being present in these 5 positions.

The classic implementation was to have one oscillator PCB hardwired to Saw and the other hardwired to Square. This is achieved as below:

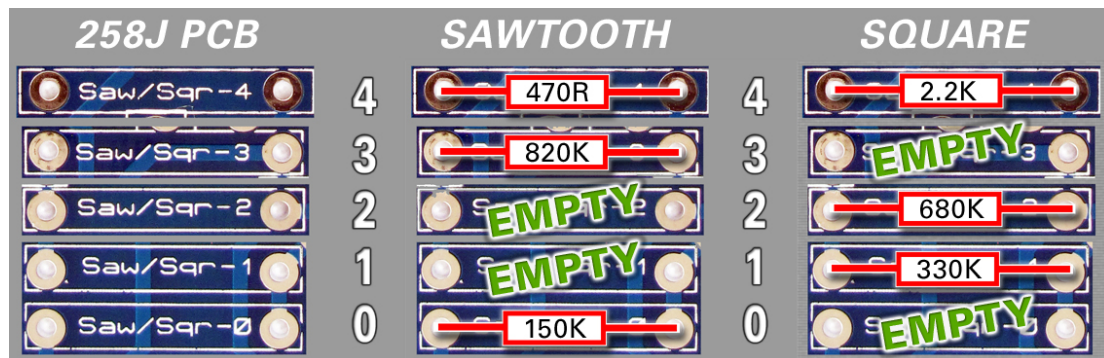

You may want to start your board by hardwiring to one waveshape first as you cannot test the board otherwise.

However you can also wire an ON-ON 3PDT switch so you can choose either Saw or Square at whim. Remember you **MUST** either hardwire **OR** wire the switch.

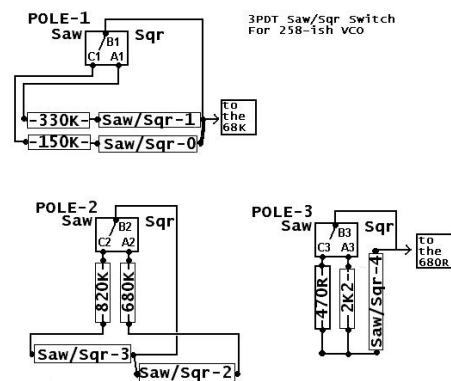

Toggle Switch (Rear View)

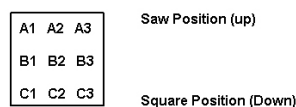

SWITCH CONTACT INFO:
Xn where "X" corresponds to position (A = Square; C = Saw; B = Common)
Xn where "n" corresponds to pole number (pole number n = 1, 2, or 3)



TEST WIRING

Ideally you shouldn't fit the ICs supplied until all soldering has been completed on the board. ICs can be damaged by excessive heat so the safe route is to do all wiring to the board first.

If you just want to test your board is working ok then the bare minimum you need to do is wire the 'Waveshape' and 'Freq' pots up, a jack on the main 'out' and your power connection.. A full wiring diagram is included at the end.

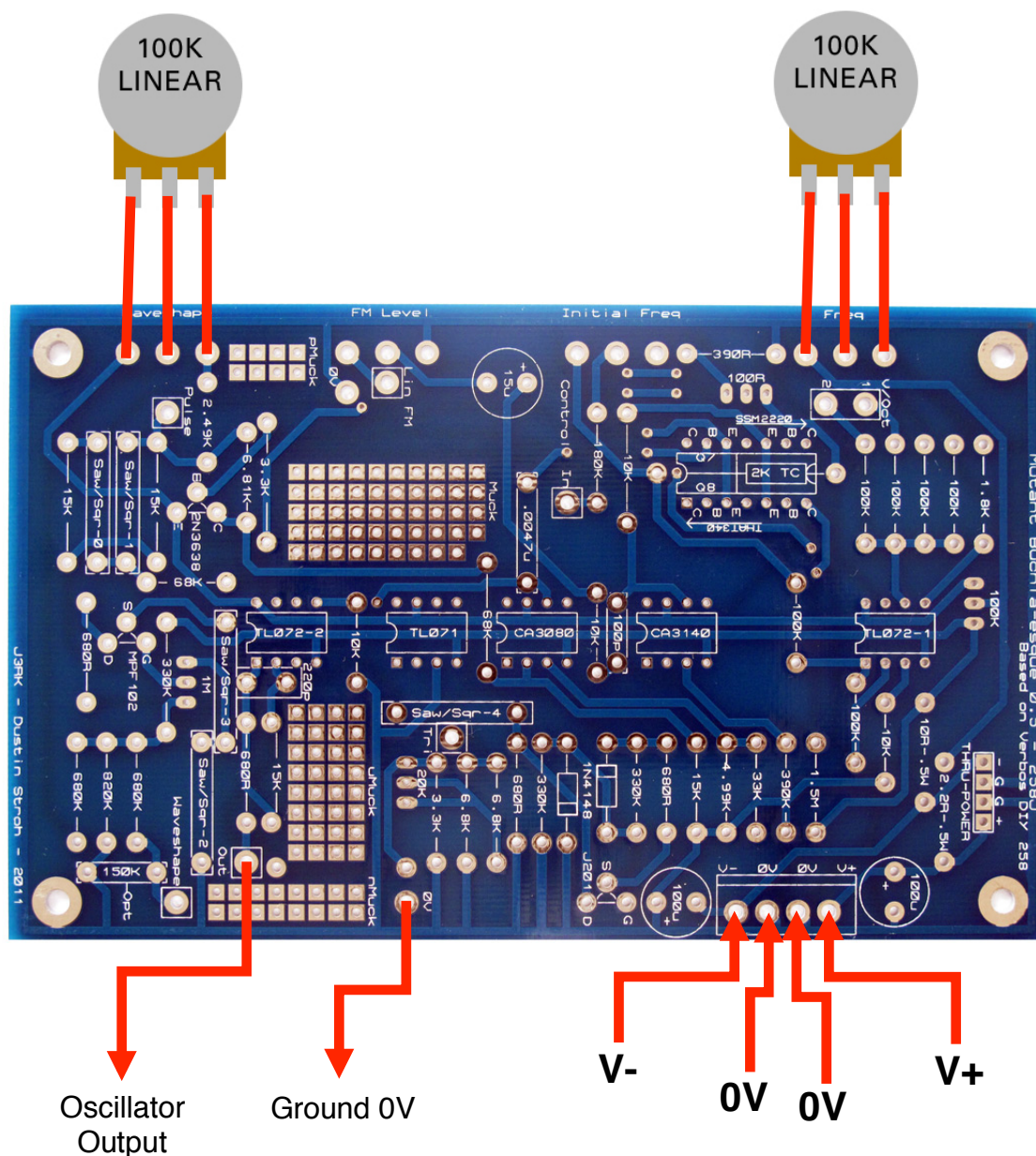



THAT340 and TEMPCO

| Component | # in kit | Notes |
|----------------------------|----------|-----------------------|
| 1 THAT340 | 1 | |
| Heat Transfer paste sachet | 1 | |
| 1 2K PTC Tempco (3500PPM) | 1 | SOLDER QUICKLY |

Next you should insert the THAT340 into the IC socket, apply a little heat transfer paste to the top face of the IC, then solder the 2K Tempco so it is resting on the far end of the IC as shown.

Take care to solder the Tempco quickly as you could damage the THAT340 if you heat it for too long.

Use the image below to make sure you position the IC the **correct** way round in the socket! The notch and circular indentation in the top of the IC should face towards the two Wima Redbox caps.

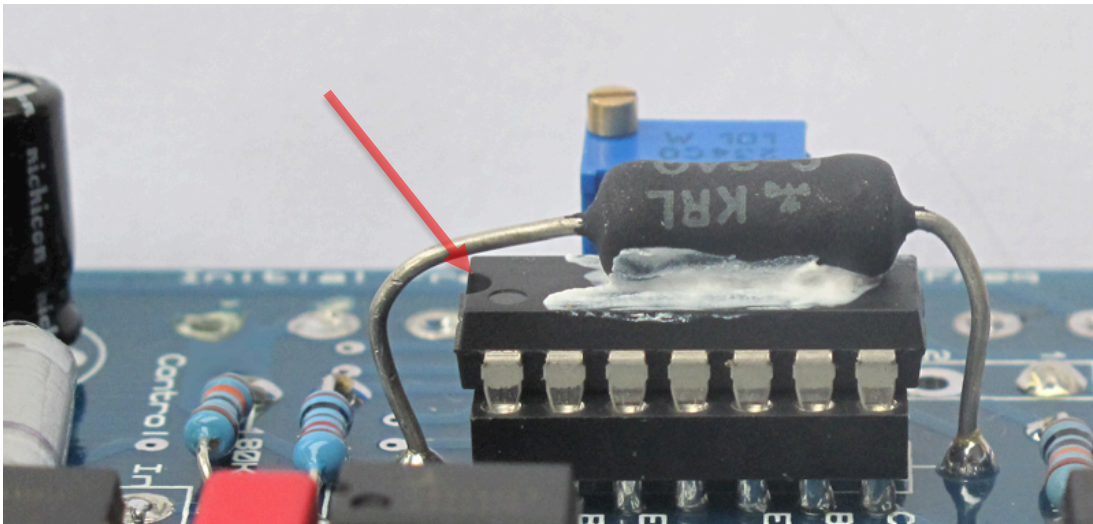

Wipe away any excess paste, make sure it's only on the top of the IC and the underside of the tempco. You really do only need a very small amount to make contact where the cylindrical body of the tempco meets the top of the IC.



REMAINING IC's

If you are finished soldering you can install the five smaller ICs.

| Component | # in kit | Notes |
|-----------|----------|-------|
| 2 TL072 | 2 | |
| 1 CA3080 | 1 | |
| 1 TL071 | 1 | |
| 1 CA3140 | 1 | |

TL072

TL071

CA3080

CA3140

TL072

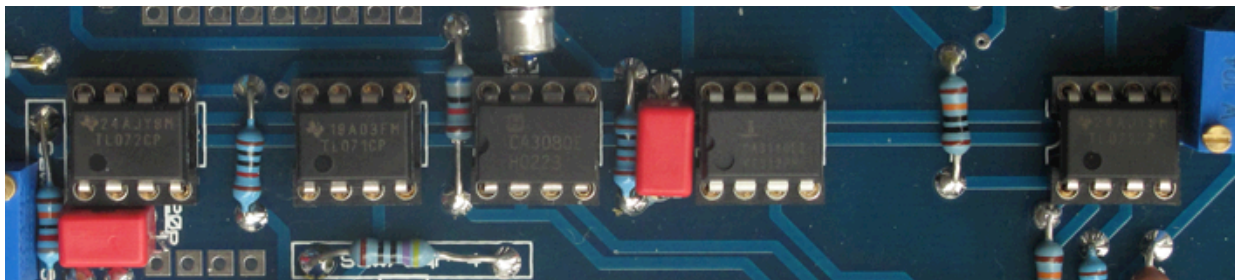



OTHER WIRING

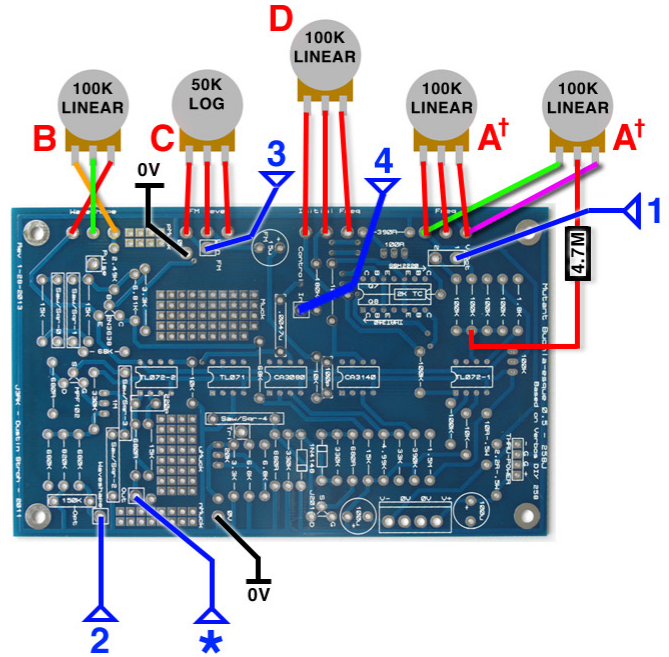

- * - FOR OUTPUTS 5&6 PLEASE READ SECTION "AMPLIFYING FOR EURORACK LEVEL OUTPUT"
 - † - YOUR CHOICE OF A1 OR A2 - SOME PREFER FINE FREQ ON LARGE KNOB FOR MORE SENSITIVITY IN FM TUNING.
- ALL JACKS SHOULD BE GROUND TO A 0V OUTPUT

TRIMMERS

- 100K Trim - Overall frequency range.
- 100R Trim - V/Oct Tracking
- 20K Trim - Sine shape
- 1M Trim – Waveshape fade

SCHEMATIC

The original Mark Verbos schematic is here: <http://www.simple-answer.com/258mod.jpg>