

Ljunggren Audio Roll Your Own Optodist

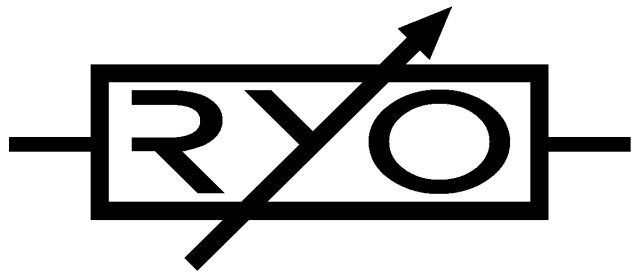

Version: Optodist/VCA 1.0
and Optodist/VCA 1.1

Bill Of Material

TYPE	PART	VALUE	PCS	NOTE
Resistor	R11,R12	10R	2	
Resistor	R5,R10	1K	2	
Resistor	R13,R14	10K	2	
Resistor	R1,R9	68K	2	If you want your Optodist to close better for VCA duties use 10K on R9. However, doing this will lessen the distortion effect.
Resistor	R2	100K	1	
Resistor	R3	100R	1	
Resistor	R4	4.7M	1	
Diode	D2,D3	SB130	2	or 1N5818. Schottky power polarity protection
Capacitor	C3,C4,C5,C6,C10,C11	100nF	6	Ceramic X7R 2.5mm
Capacitor	C2,C9	100pF	2	Ceramic C0G 2.5mm
IC Socket	IC1,IC2	8 pin	2	
OpAmp	IC1,IC2	TL072	2	or TL082
Optocoupler socket	LDR1 x2, LDR2 x2	2 pin	4	One for each side of the optocouplers.
Optocoupler	LDR1,LDR2	SR2/SR3	2	Silonex NSL-32SR2 or NSL-32SR3 "vactrol"
Electrolytic	C7,C8	10µF	2	2mm pin pitch, 5mm dia, 5mm height
Transistor	Q1	BC557B	1	
Transistor	Q2	BC547B	1	
Trimmer	TRIM1	2K	1	Gain range calibration
Jack	J1,J2,J3	3.5mm	3	PJ301BM
Rotary Pot.	POT1	100K lin	1	CV Att.
Rotary Pot.	POT2	22K lin	1	Or 25K lin. Gain
Rotary Pot.	POT3	100K log	1	Signal in Att.
Switch	SW1	SPDT	1	On-On
LED	D1	Orange	1	3mm
LED	D4,D5,D6,D7	Green	4	3mm, LED limiter, other colours may be used.
Power header	POWER	10 pin	1	boxed
Knobs	Small fluted skirtless	cream	3	
Screws	Black, Pozi	M3x6	2	Mounting screws
PCB			1	
Faceplate	PCB material (FR4)	black	1	
Power cable	Eurorack power cable		1	10pin ↔ 16pin

Changes from version 1.0 to 1.1

- The unused R8 resistor footprint is removed.
- The holes for the potentiometer housing pins is enlarged to accommodate both standard 9mm Alpha and custom pots.
- Square instead of round pads on the jack housing pins.
- Different PCB colour.

Please note: Text in red (same type of red as this text) indicates errors in the photos taken before final assembly instructions were written. These errors will be addressed in the next version of the assembly manual.

Assembly instructions

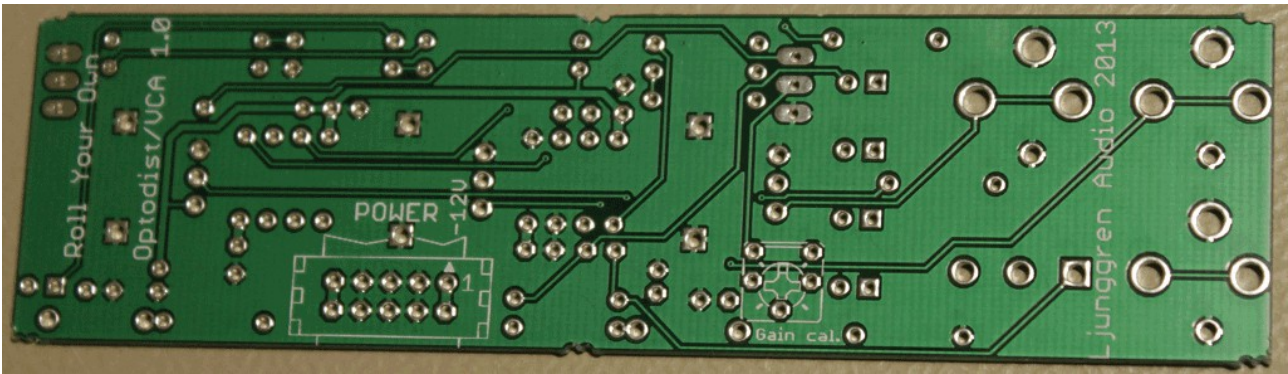

Empty PCB bottom Optodist 1.0

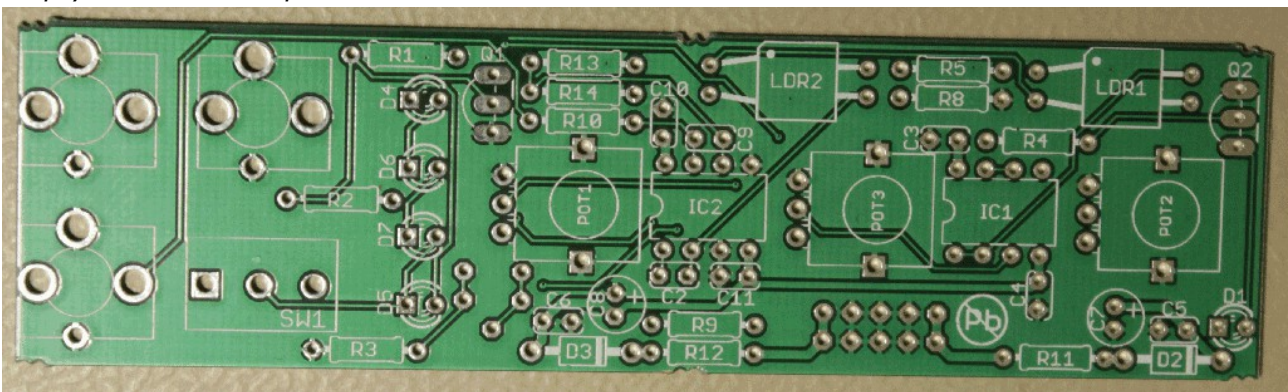

Empty PCB top Optodist 1.0

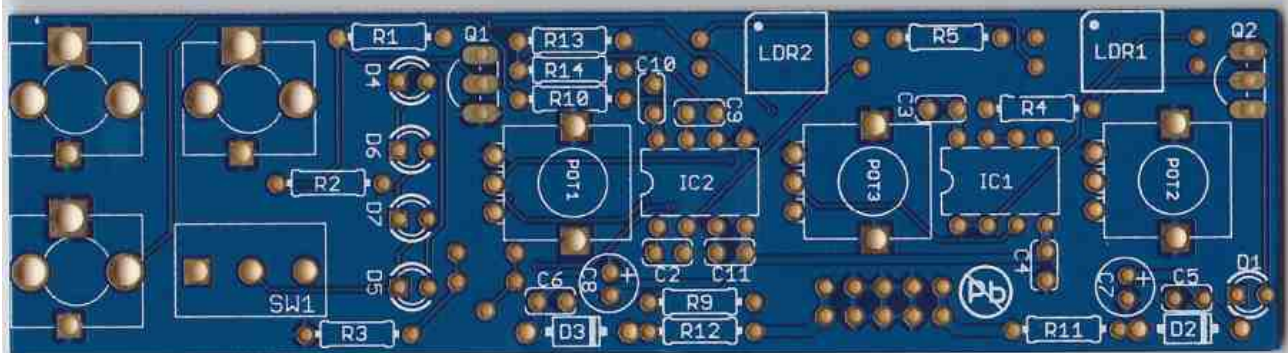
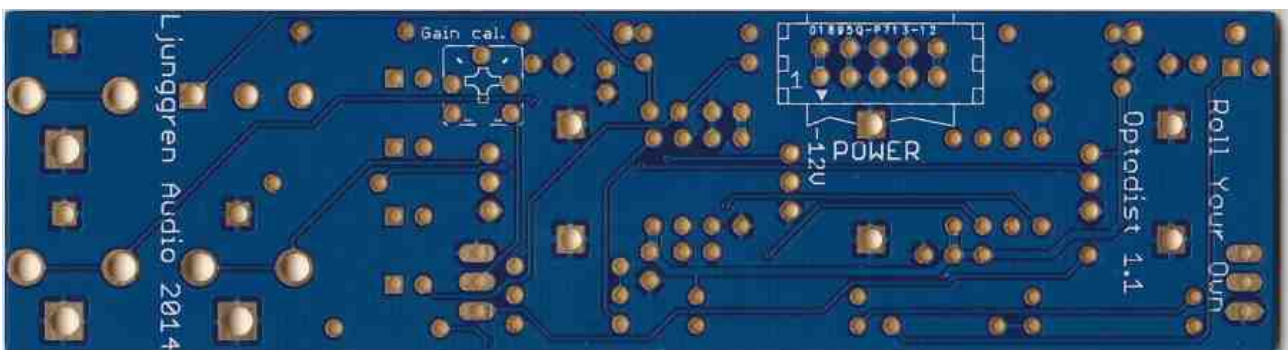

Empty PCB bottom & top Optodist 1.1

Step 1

Solder resistors. Resistors are not sensitive to mounting direction.

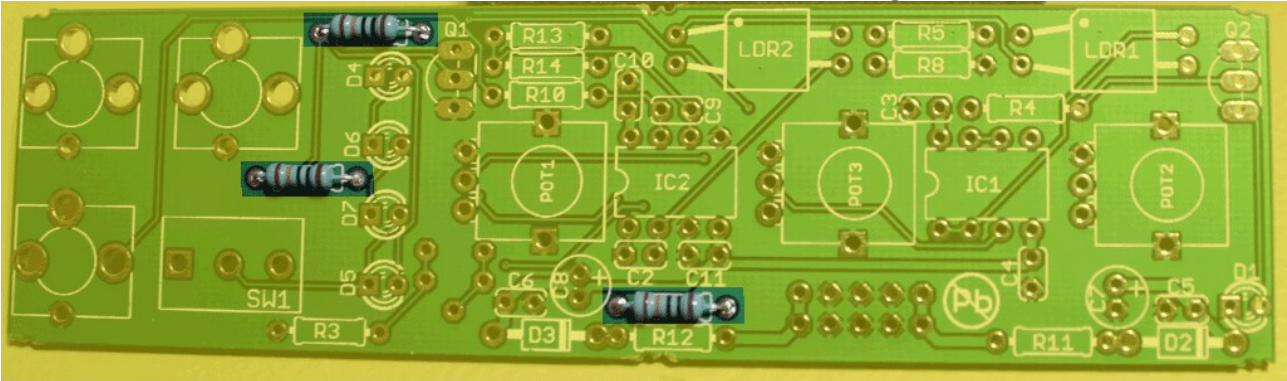

R1 68K, R2 100K, R9 68K

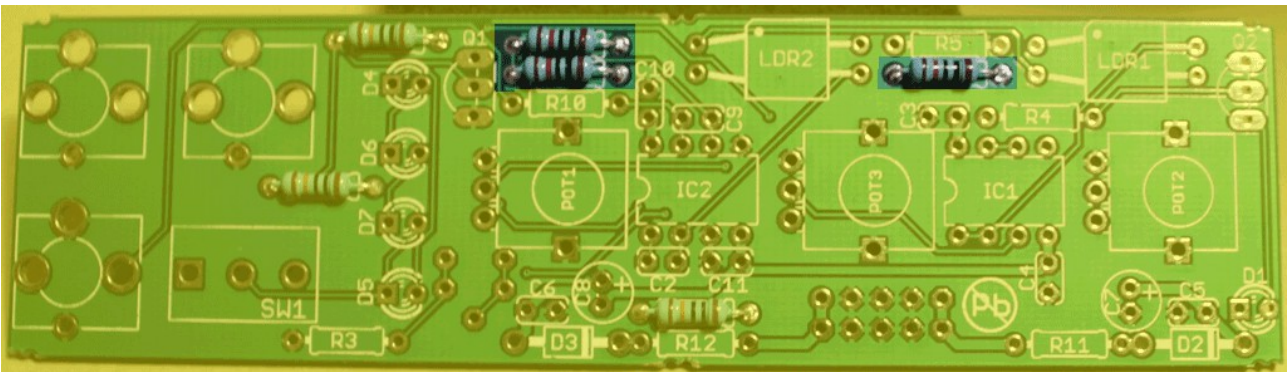

R8 skip this one, R13 10K, R14 10K

*R8 is unnecessary but present in all photos, don't solder it at all.
On version 1.1 this is removed.*

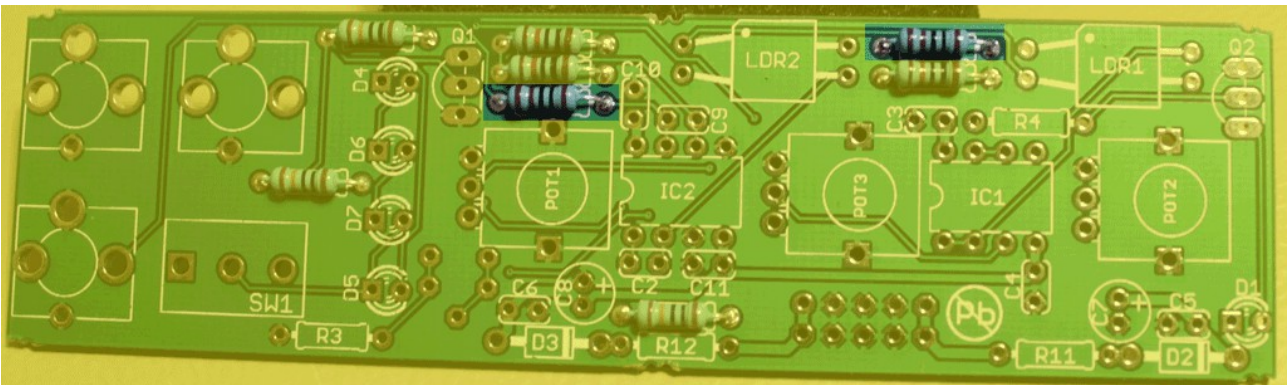

R5 1K, R10 1K

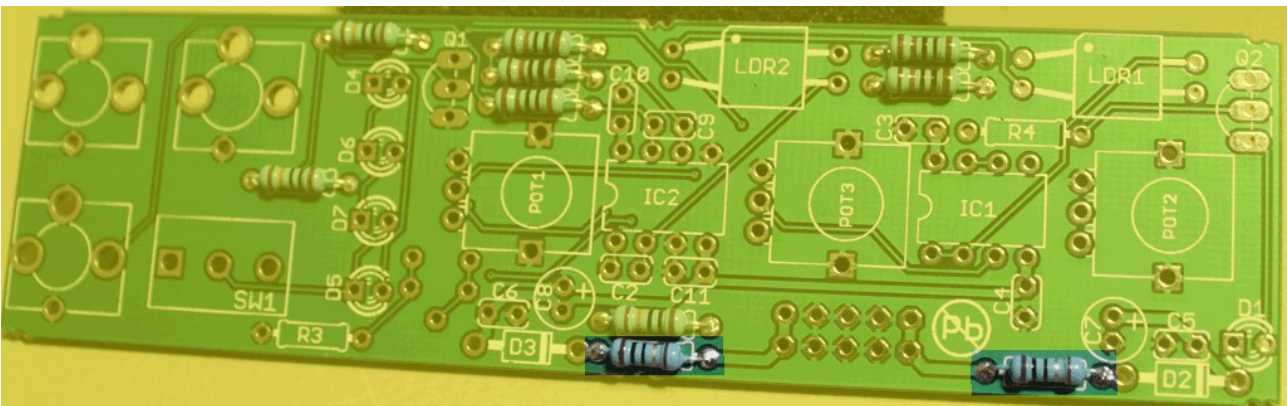

R11 10R, R12 10R

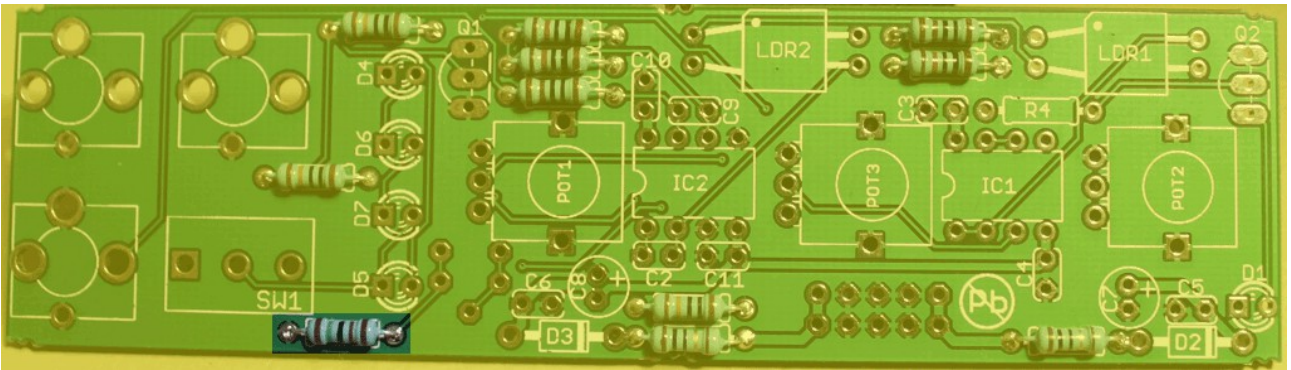

R3 100R

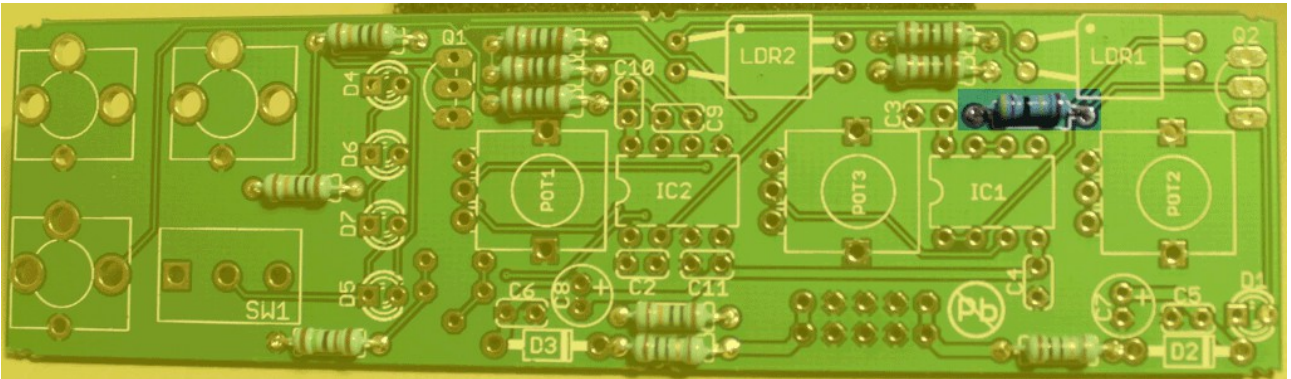

R4 4.7M

Step 2

Solder reverse polarity protection diodes. The stripe on the diodes must be on the same side as indicated in the silk screen.

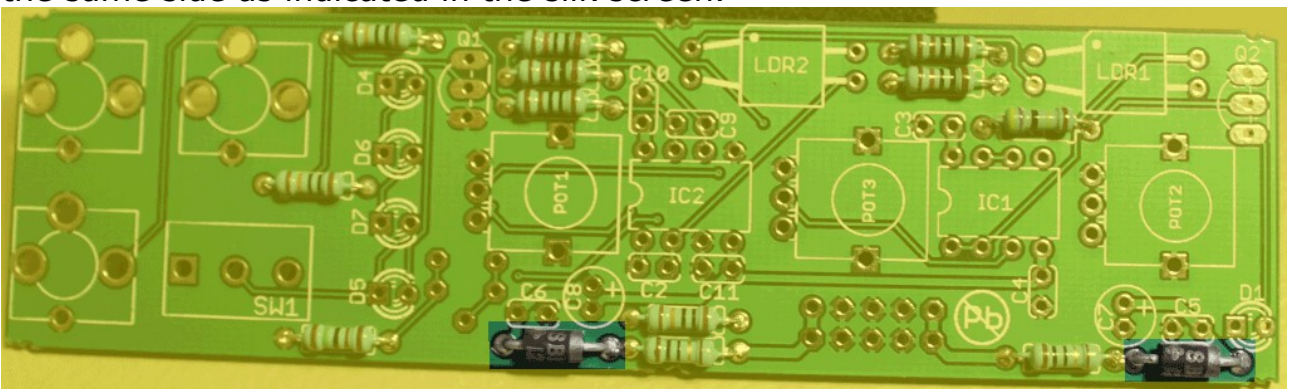

D2 SB130, **D3** SB130

Step 3

Solder ceramic capacitors. Ceramic capacitors are not sensitive to mounting direction.

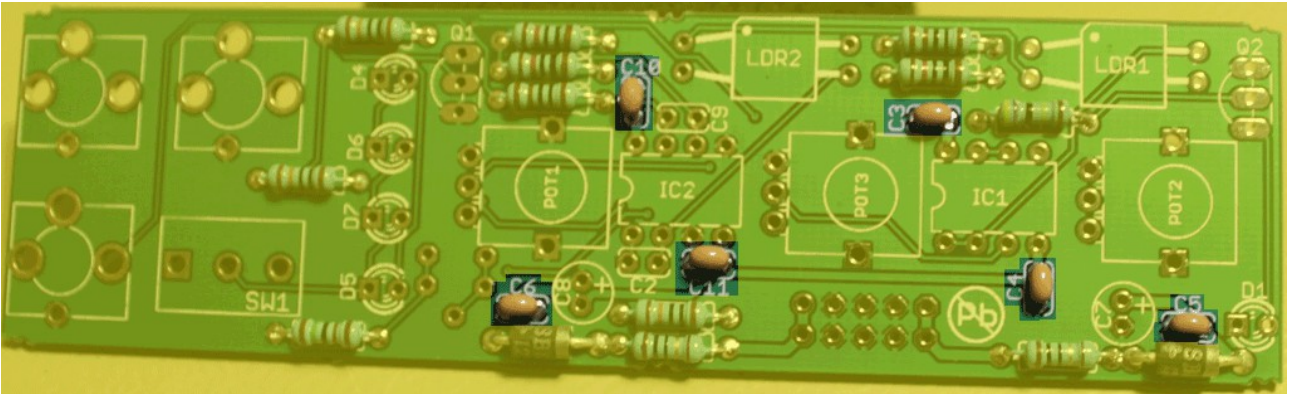

C3 100nF, **C4** 100nF, **C5** 100nF, **C6** 100nF, **C10** 100nF, **C11** 100nF

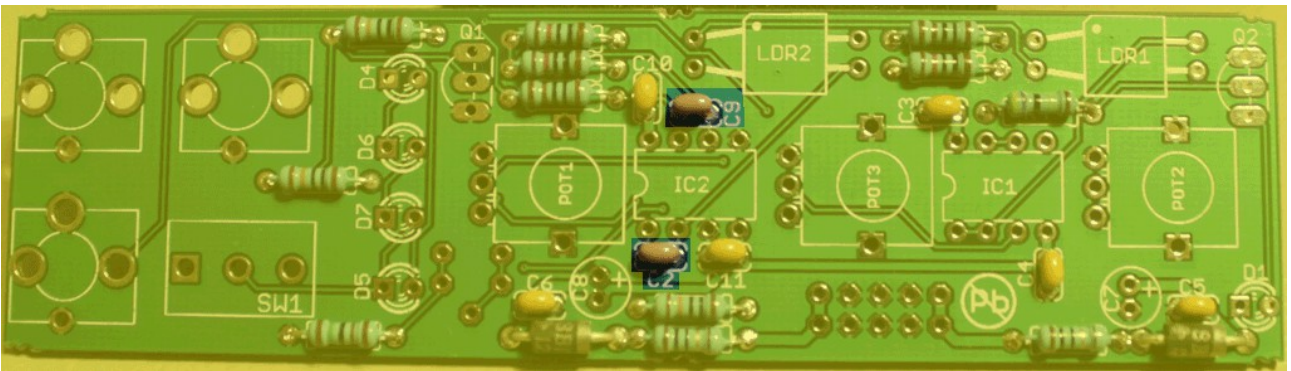

C2 100pF, **C9** 100pF

Step 4

Solder sockets. Match the IC sockets indent (pin 1) with the silk screens.

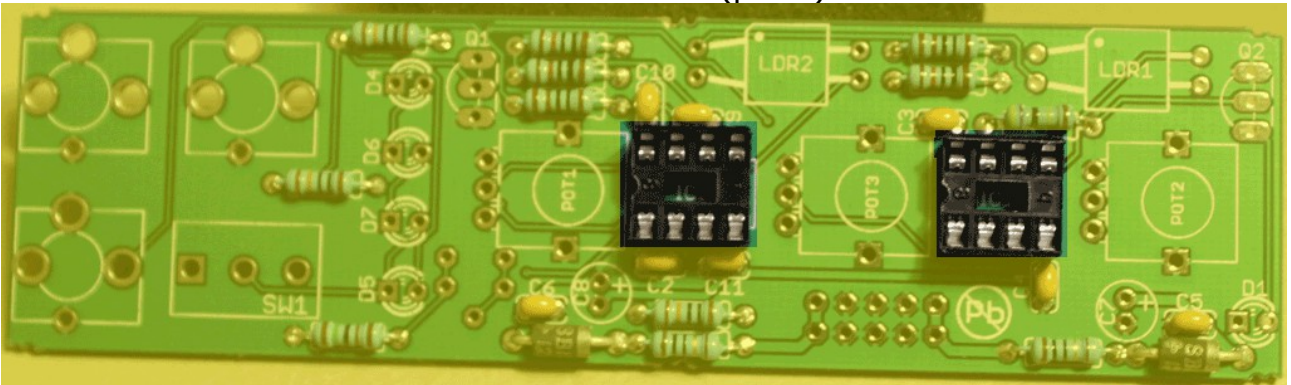

IC1, **IC2** sockets. IC's will be mounted later.

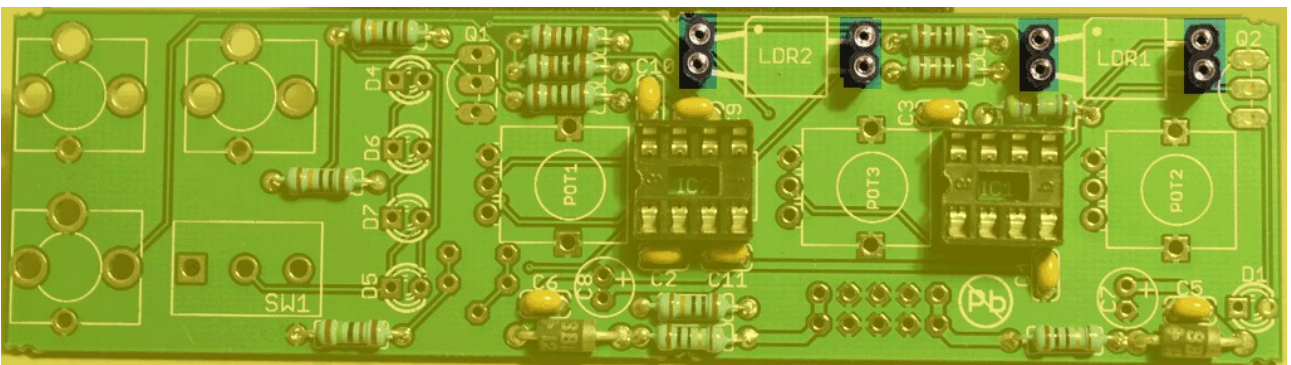

LDR1, **LDR2** sockets. Not sensitive to mounting direction. Optocouplers will be mounted later.

Step 5

Solder Electrolytics. Long leg is + (anode).

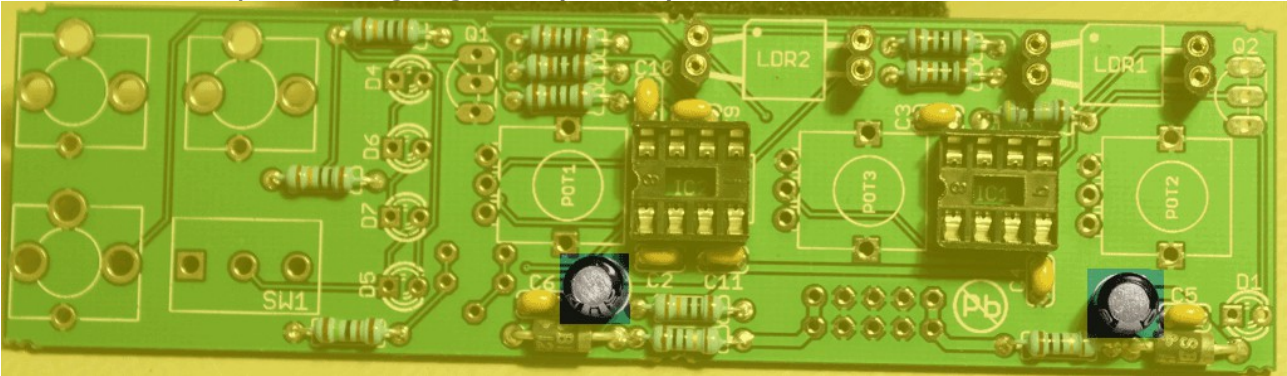

C7 10 μ F, **C8** 10 μ F

Step 6

Solder transistors. Match the curved side with the silk screen.

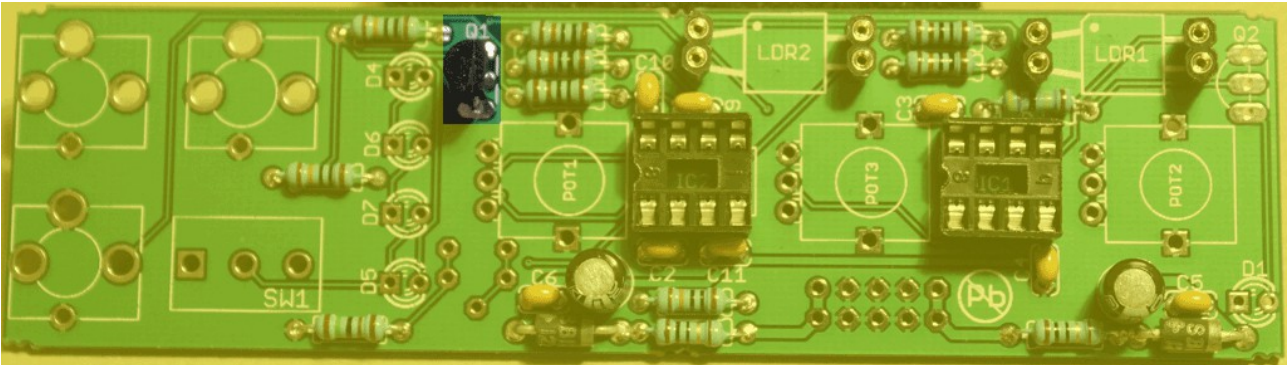

Q1 BC557B

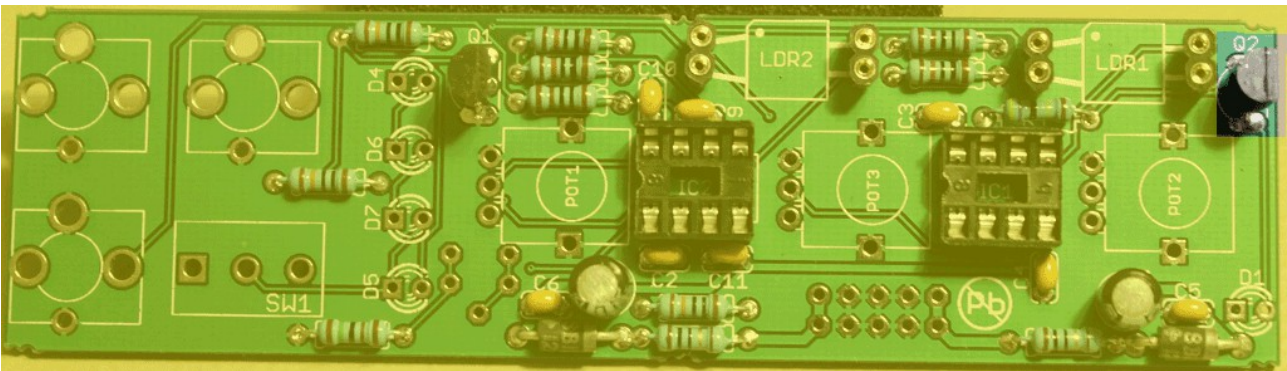

Q2 BC547B

Step 7

Solder trimmer. Only 3 of the 5 holes are used, the extra 2 holes are for fitting trimmers with different appearance.

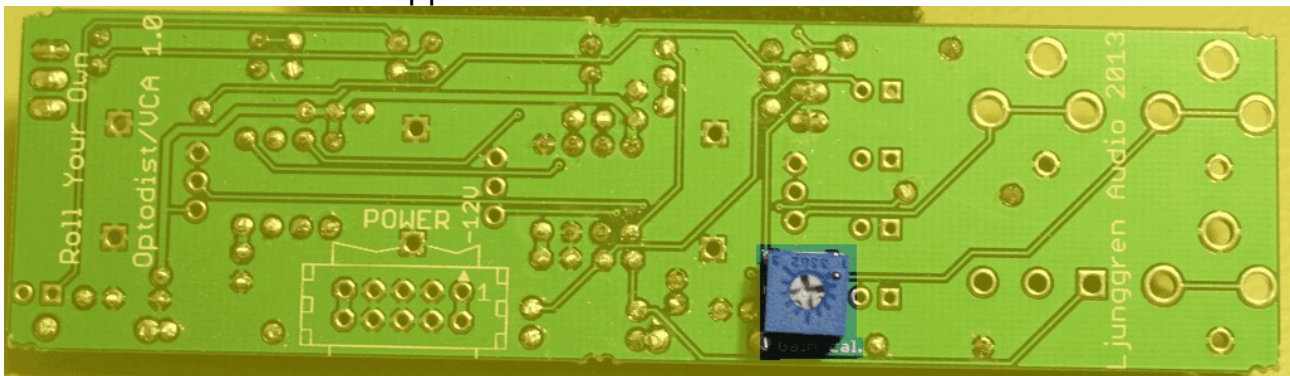

TRIM1 2K

Step 8

Solder jacks.

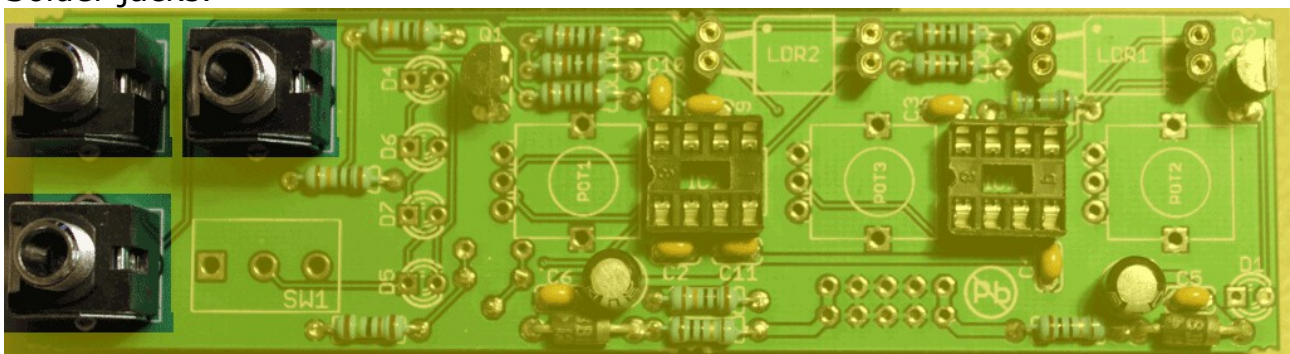

J1, J2, J3

Step 9

Remove the nuts and washers from the potentiometers. Cut off the small metal tab sticking out indicated by a red circle below and solder them in place. **Please pay attention that POT1, POT2 and POT3 is not placed in a linear order. The order from left to right (or bottom to top) is POT1, POT3, POT2.**



POT1 100K linear

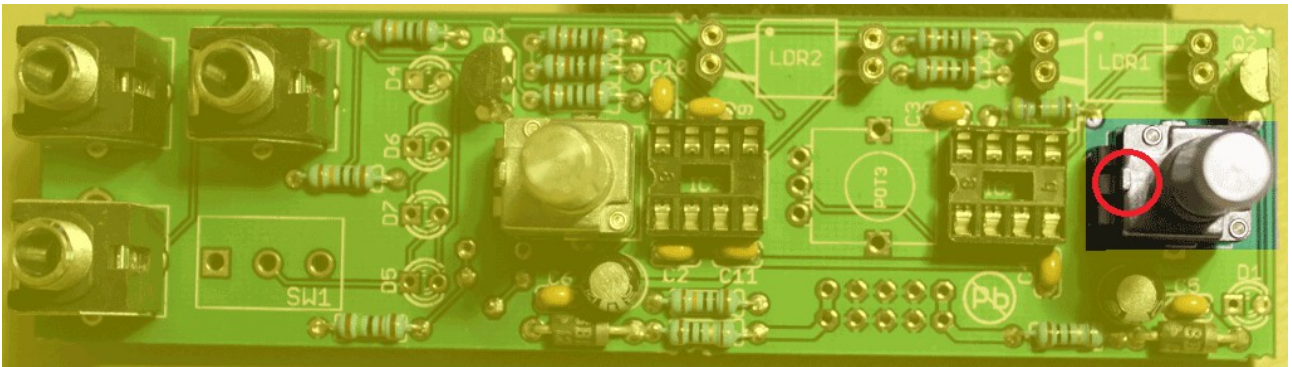

POT2 22K linear or 25K linear

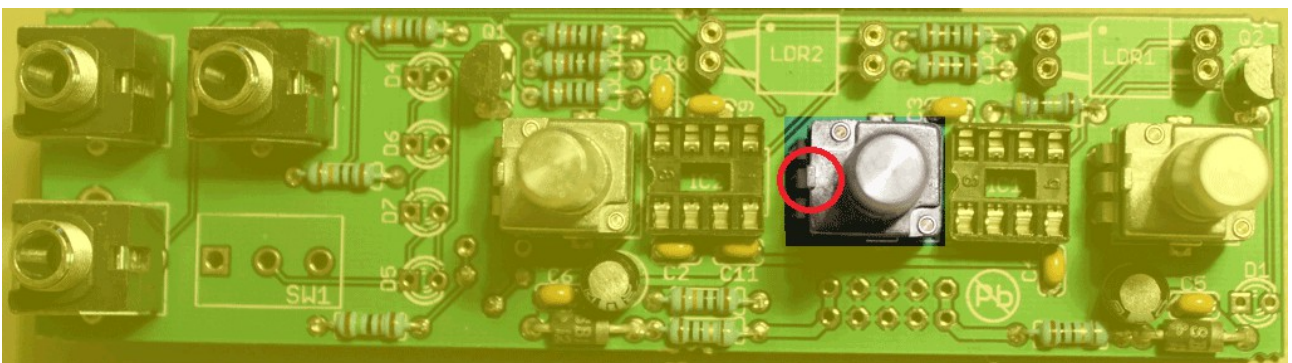

POT3 100K logarithmic

The following 2 steps (switch and LED's) can be done at the same time if you wish.

Step 10

Remove the nuts and washers on the switch. The nuts are very similar looking to the jack nuts but they are not the same. The jacks nuts will not fit on the switch but the switch nuts will fit on the jacks so be careful not to mix them up with each other.

Mount the switch without soldering it.



Mount the panel in the places shown in the picture above. You don't need to tighten the nuts very hard, use your hands, no tools needed.



If you have Alpha potentiometers like the one on the left you place **one washer under the panel and one nut over the panel.**

The last kits with these pots were shipped in May 2014 and is long gone by now.

If you have custom potentiometers like the one on the right you place **two washers and one nut under the panel** and **one washer and one nut over the panel.** This is what is included in our kits after May 2014.

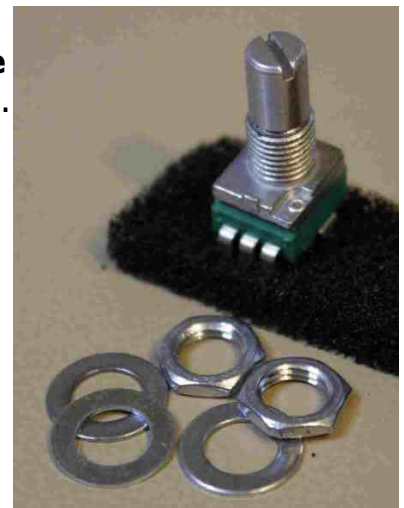

Now solder the switch in place and remove the panel afterwards.

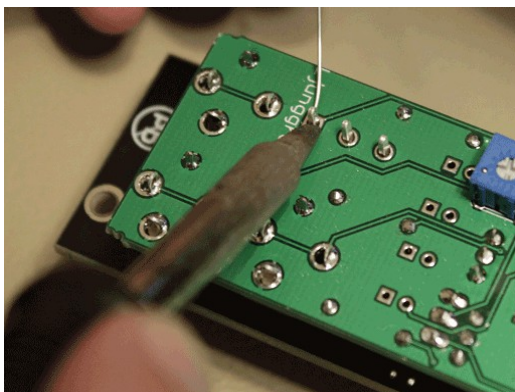

SW1

Step 11

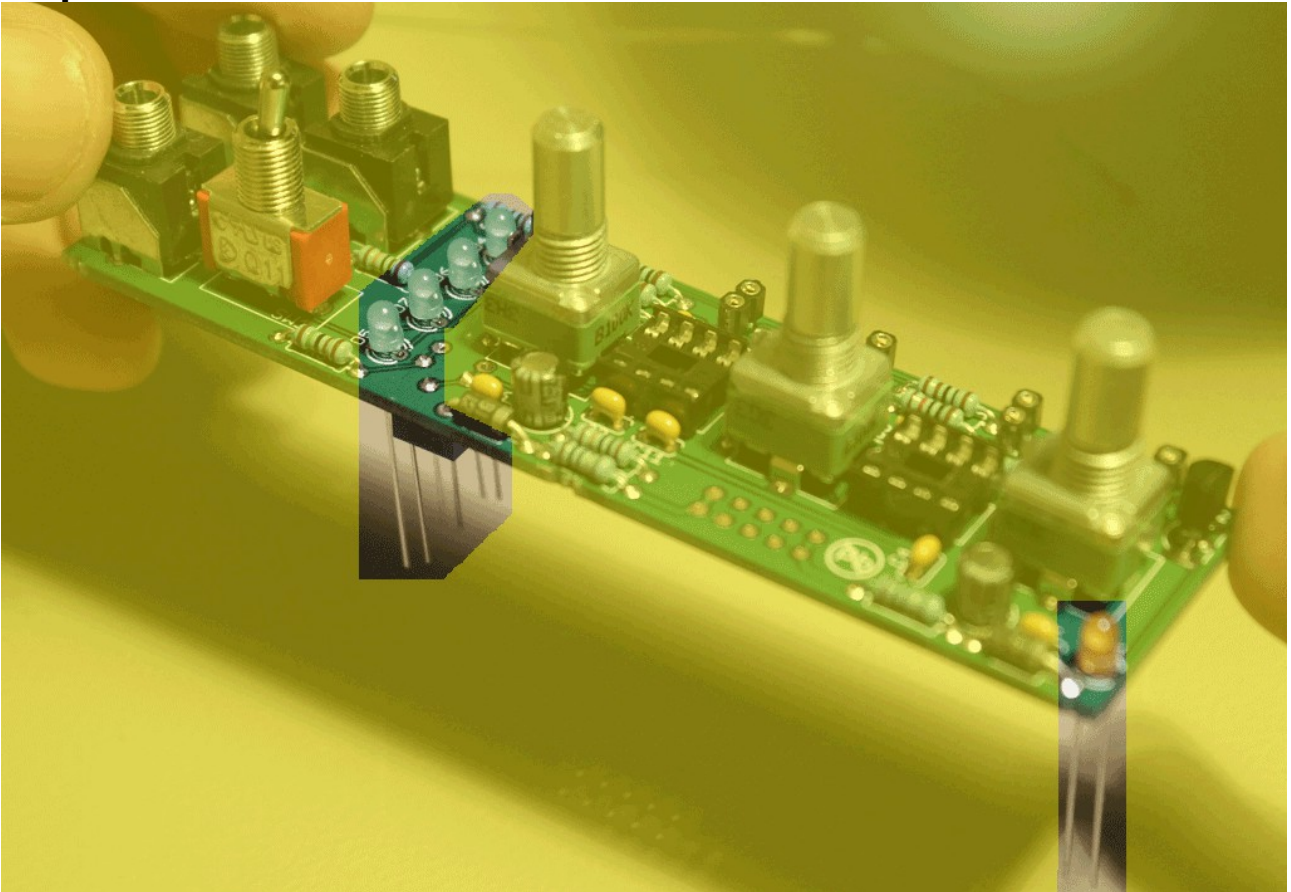

D4, D5, D6, D7 (LED limiter), **D1** (orange)

The long leg of the LED's (anode, +) goes in the square hole.
Put the LED's in place (don't solder yet) and temporary mount the panel the same way as in the previous step. Carefully flip the module over.

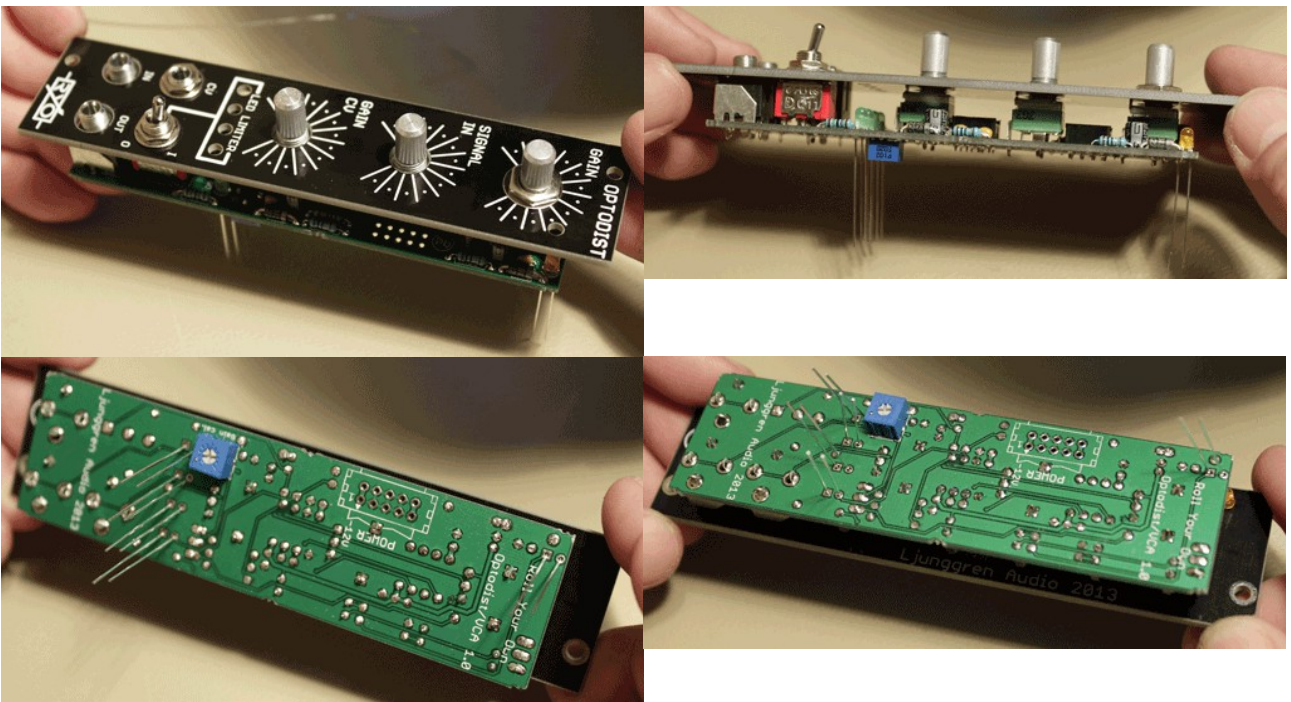

Correct the LED positions with your hands making sure each LED has slotted into their respective panel hole. Solder them in place.

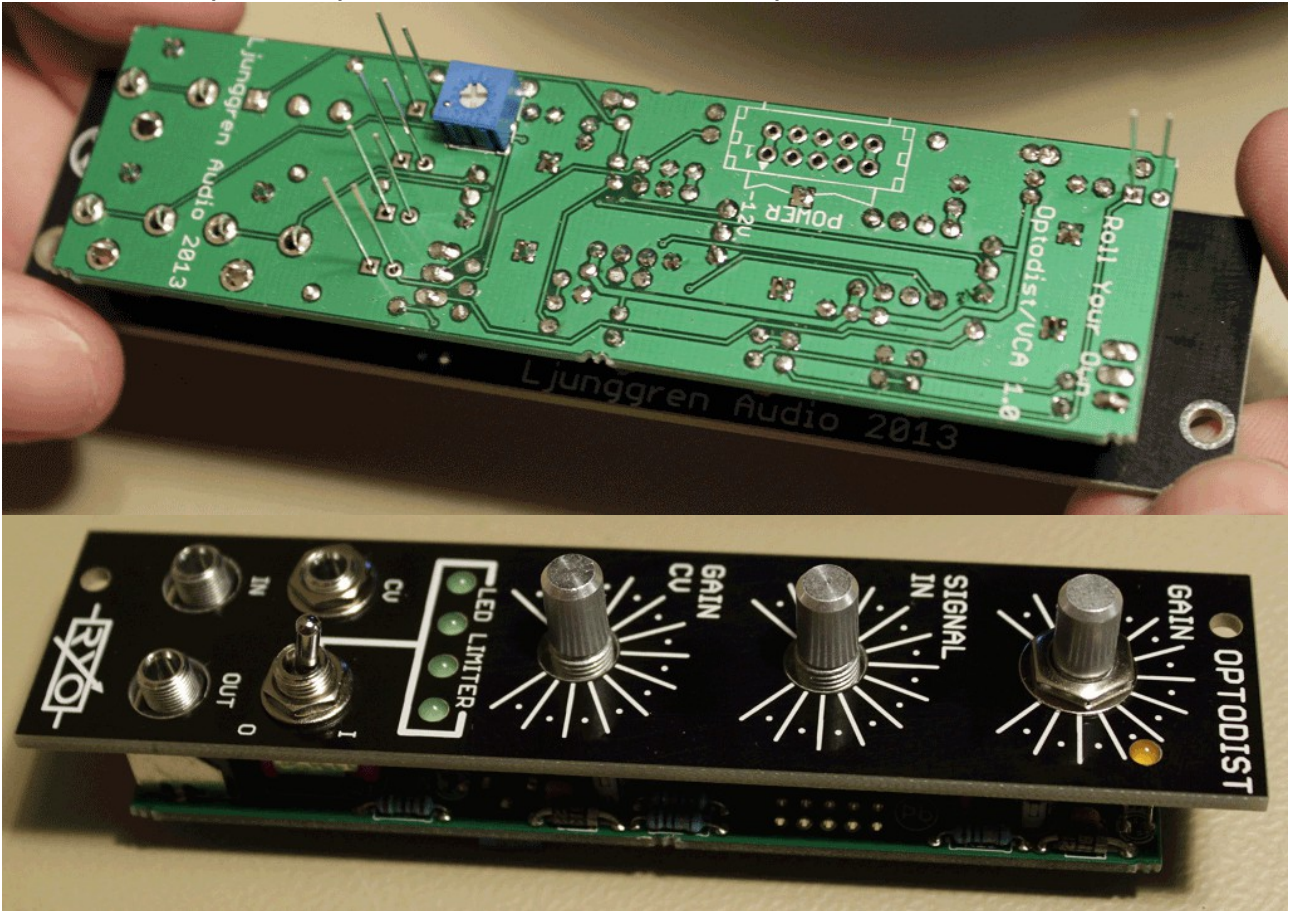

Step 12

Solder the keyed boxed power header. Pay extra attention to the direction. The triangle (pin 1) must be at the -12V side. In the picture below you can see the direction of the keyed opening in the boxed header.

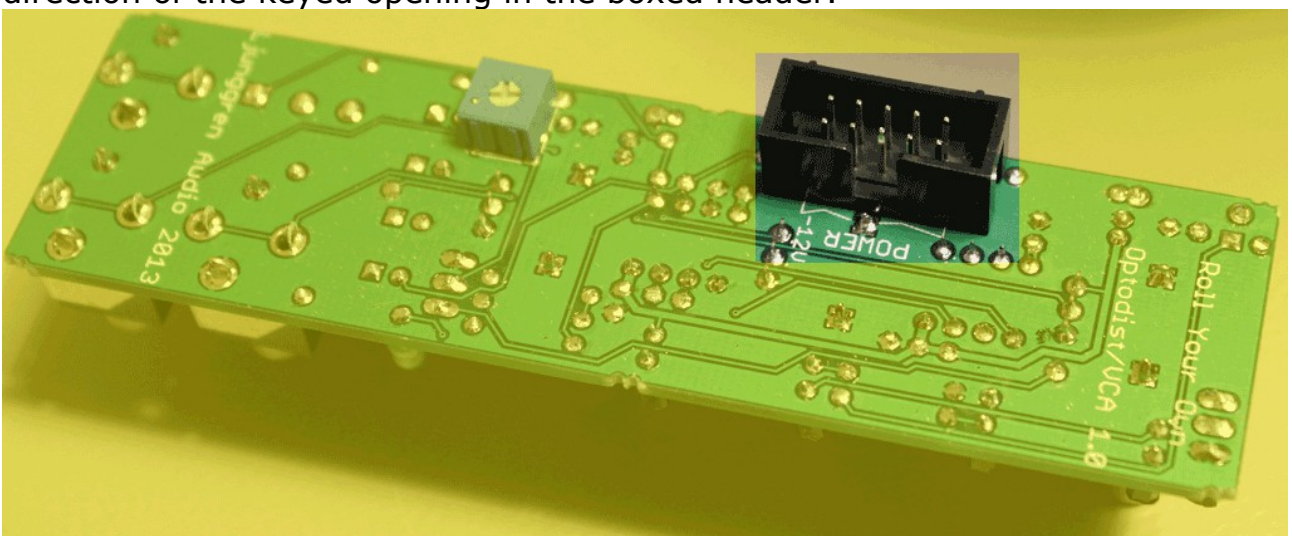

POWER

Step 13

Mount the IC's and optocouplers.

The IC's indent or dot marking pin 1 must match the silk screen direction. Be careful not to cut the legs too short on the optocouplers. Make sure the Optocouplers dot match the dot/bevel marking in the silk screen.

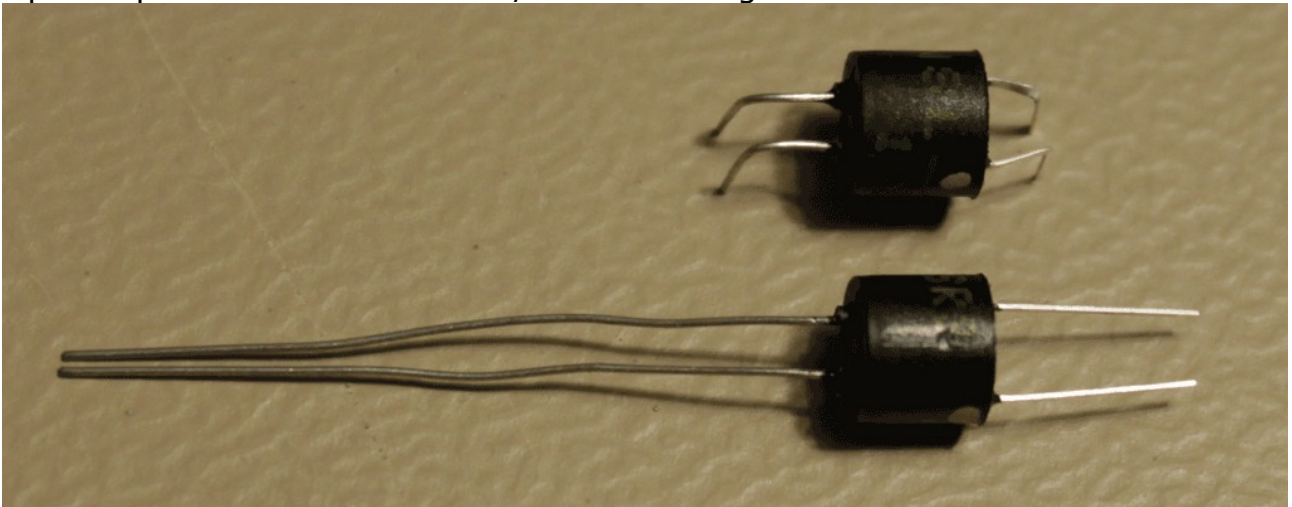

Step 14

Mount the panel. Use 8 mm wrench socket for the jacks and switch and 10 mm for the potentiometers.

Switch: Only use one of the originally attached switch nuts and none of the original switch washers. Instead use the same washer model as for the jacks (included in the switch bag). No washers under the panel.

Potentiometers: Use the washers that was originally attached to the potentiometers under the panel and the nut over the panel.

Jacks: No washers under the panel. One washer and one nut per jack over the panel.



Step 15

Mount the knobs on the potentiometers.

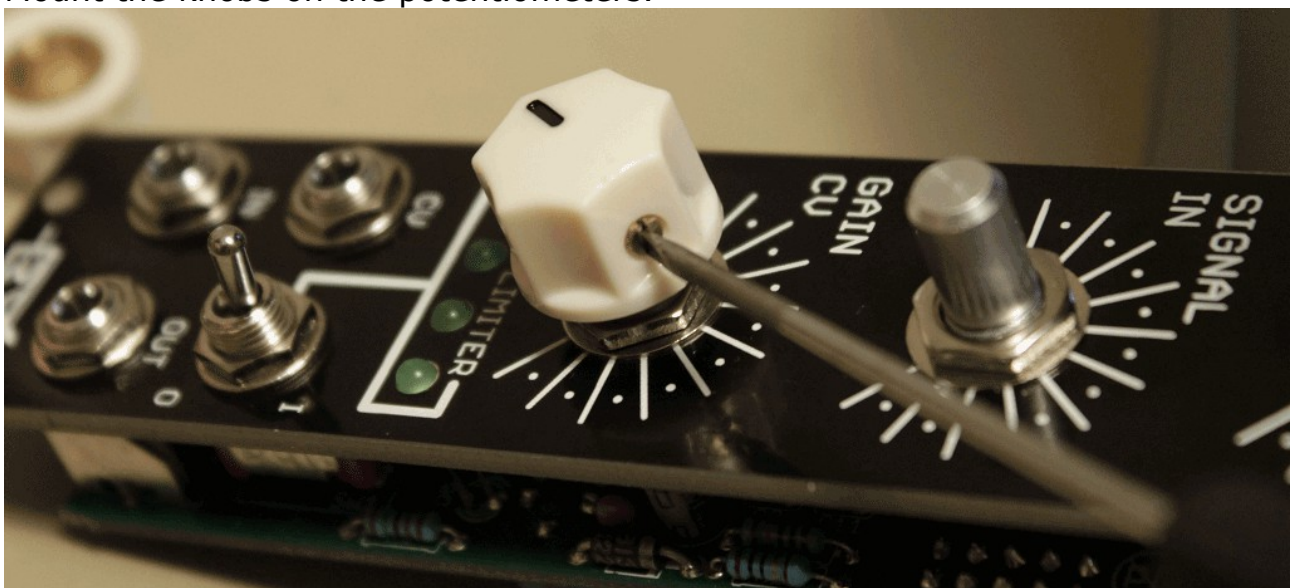

Calibration

1.

Patch an audio signal with a relatively clean waveform that is easy to hear when clipping starts on, for example a sine. Listen to the audio signal.

2.

Turn up Gain fully CW (clock wise, right) position.

Turn up Signal In to fully CW (clock wise, right) position.

Turn down Gain CV fully CCW (counter clock wise, left) position.

3.

Adjust trimmer until you are satisfied with the maximum gain amount. The output will be much louder with the LED limiter off than on.