

Multi Mode Transistor Ladder Filter

Build Guide

Dannysound

1 Introduction

2 Construction Tips

3 Parts Lists

4 Initial Resistors

5 Outer Board

6 Mid Board

7 Pots Board

8 Panel Components and Final Assembly

9 Testing and Calibration

10 Modifications

1 Introduction

The Multi-Mode Ladder (MML) Filter is based on the classic transistor ladder low pass filter by Dr. Robert A. Moog.

The MML Filter has been updated from the classic Moog design to provide Band Pass and High Pass filter responses as well as the traditional Low Pass filter, it also provides CV control over the resonance.

The circuit features a fully discrete transistor design with an op-amp buffered output, this allows soft saturation of the input to get the classic overdriven tones of the ladder filter.

A bass compensation circuit has been included to retain the bass response in Low Pass mode when the resonance is increased. The bass compensation also helps to improve the response of the High Pass filter.

The bass compensation can be removed if the user wishes to have a more classic response (see modifications section at end).

Features:

Low Pass, Band Pass and High Pass modes.

CV controlled resonance.

Bass compensation.

Soft saturation of input.

2 x frequency CV inputs.

Controls:

1 x Filter mode selector switch

1 x Frequency control pot

1 x Resonance control pot

Connections:

Inputs

2 x Frequency CV

1 x Resonance CV

1 x Audio

Output

1 x Filter Output

2 Construction Tips

These tools come in very handy, especially if you do a lot of DIY projects. They should be available from most electronics hobbyist stores.

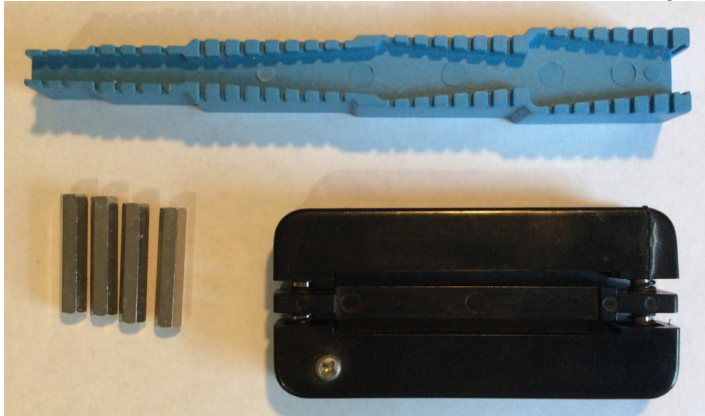

The blue bending gauge is for bending the resistor and diode legs to the right size.

The black IC straightener is for straightening pins of op-amps etc.

The silver standoffs are 25mm Female to Female.

You can use this setup with the 25mm standoffs for inserting the resistors and diodes.

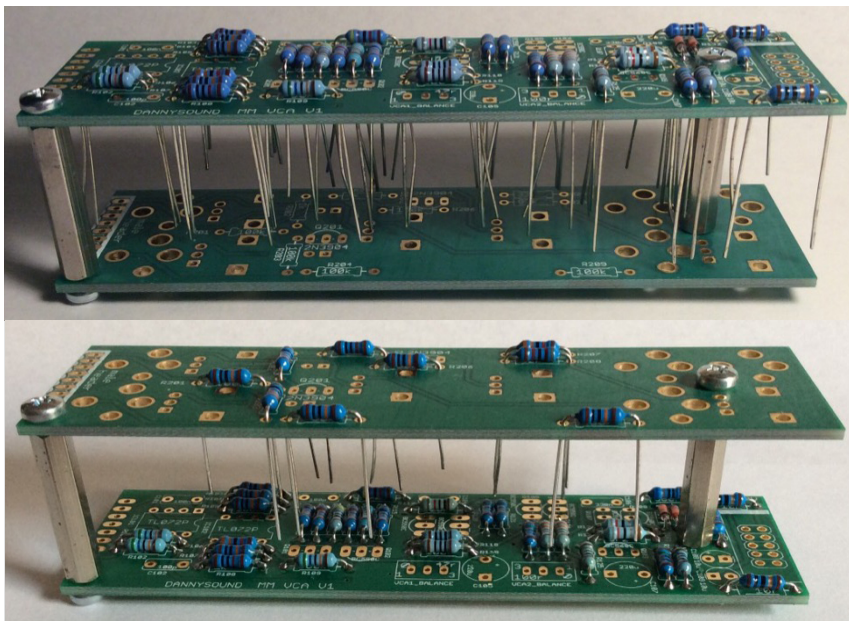

The top picture is for stuffing the Outer Board. It has the advantage of being much quicker to place all the resistors etc and it's easy to fix any mistakes. You can then solder everything from the top in one go (make sure you have decent temp. solder iron with not too fat tip!). Then unscrew the standoffs and clip all the legs. Reverse both boards as in the lower picture for the Pots Board.

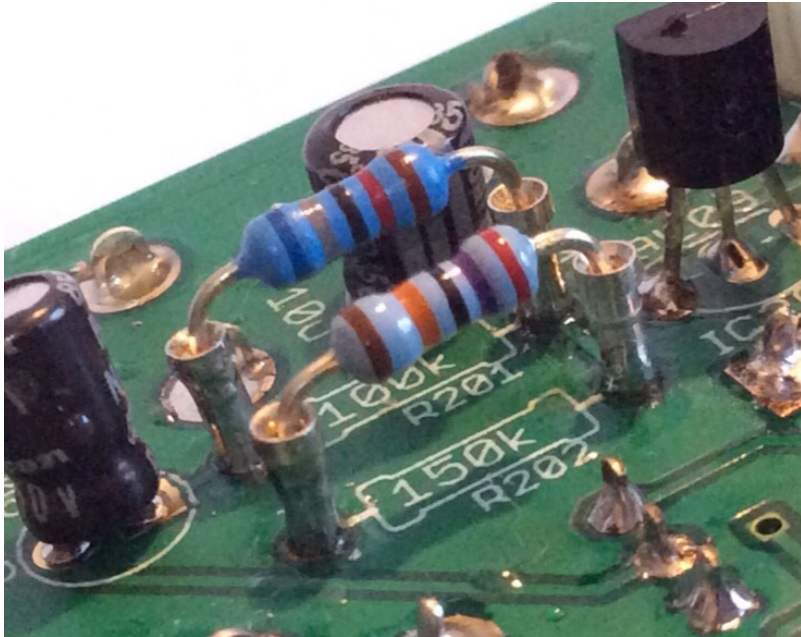

Cutting the pins from a SIL connector and soldering as shown above is useful for experimenting with different component values if you want to try out any of the modifications.

3 Parts Lists

MML FILTER OUTER PARTS LIST		
-----------------------------	--	--

RESISTORS		
10r	2	R100 R101
150r	4	R107 R109 R110 R112
200r	1	R104
220r	1	R111
330r	1	R123
470r	1	R105
680r	1	R102
820r	1	R106
1k	3	R113 R118 R122
1k2	1	R108
1k8	1	R121
2k2	1	R115
33k	1	R103
47k	2	R116 R120
68k	1	R114
220k	2	R117 R119

CAPS		
22n polyester box 5mm pitch leads	4	C104 C105 C106 C107
220n polyester box - 5mm pitch leads	2	C108 C109
680n polyester box - 5mm pitch leads	1	C112
10u electrolytic	2	C103 C110
100u electrolytic	3	C111 C100 C102
220u electrolytic	1	C101

VACTROL		
VTL5C3	1	U100

TRIMPOT		
4k7 OR 5k	1	RES

TRANSISTORS		
		Q102 Q103 Q104 Q105
BC550	6	Q106 Q107
BC550	2	Q108 Q109
BC550	2	Q100 Q101
BC550	2	Q112 Q111
BC550	2	Q110 Q113

MATCHED PAIR
MATCHED PAIR
MATCHED PAIR
MATCHED PAIR

REGULATORS		
78L05	1	Q114

HEADERS		
---------	--	--

1 X 6 FEMALE	1
1 X 5 FEMALE	1
1 X 4 FEMALE	1
Shrouded 2 x 5 power socket	1

MML FILTER MID PARTS LIST

RESISTORS		
330r	1	R215
1k TEMPCO small	1	R208
1k	3	R211 R214
1k2	1	R216
2k	1	R206
2k2	1	R201
10k	1	R218
22k	1	R222
39k	1	R221
47k	2	R209 R213
82k	1	R204
100k	4	R202 R203 R205 R223
120k	1	R217
150k	1	R219
180k	1	R220
220k	2	R210 R212
680k	1	R225
1M	2	R200 R207

CAPS		
100p 2,5mm pitch leads ceramic	1	C201
100n polyester box - 5mm pitch leads	1	C208
220n polyester box - 5mm pitch leads	2	C203 C202
680n polyester box - 5mm pitch leads	2	C205 C207
10u low profile	2	C204 C206

DIODES		
1N4148	1	D200

TRIMPOTS		
500r SIDE ADJUST	1	V/OCT
100k SIDE ADJUST	3	BPT HPT FRQ_TRM

TRANSISTORS		
2N3904	2	Q200 Q201
BC550	2	Q203 Q204
BC550	2	Q202 Q205

MATCHED PAIR
MATCHED PAIR
MATCHED PAIR

ICs		

DG202	1	IC201	PROGRAMMED
LF412	1	IC200	
PIC12F509	1	IC202	
TL072	1	IC203	

HEADERS	
1 X 6 MALE	1
1 X 5 MALE	1
1 X 4 MALE	1
1 X 8 FEMALE	1
1 X 6 FEMALE	1

MML FILTER POTS PARTS LIST

RESISTORS		
1k	4	R302 R303 R304 R305
100k	2	R300 R301

ALPHA POTS		
100k	2	FREQ RES

TALL TRIMMERS		
100k	3	IN_VOL CV1 CV2

LED		
AMBER 3MM	3	HP BP LP
RED 3MM FLAT TOP	2	CV1 CV2

TRANSISTORS		
2N3904	2	Q300 Q301

SOCKETS		
PJ301	5	

PUSH SWITCH		
TL2201 MOMENTARY	1	SW

HEADERS	
1 X 8 MALE	1
1 X 6 MALE	1

MML FILTER HARDWARE

STANDOFFS	
M3 MALE-FEMALE 12MM	3
M3 FEMALE 11MM	3

SCREWS	
--------	--

M3	6
----	---

KNOBS	
ROGAN SKIRT SMALL	1
ROGAN SMALL	1
RED BUTTON	1

MOUSER 611-PVRD

LIGHTPIPES	
3mm	3
5mm	2

MOUSER
VCC mouser 593-
LFC025CTP

4 Pot Board 1K resistors

Locate the Pots PCB

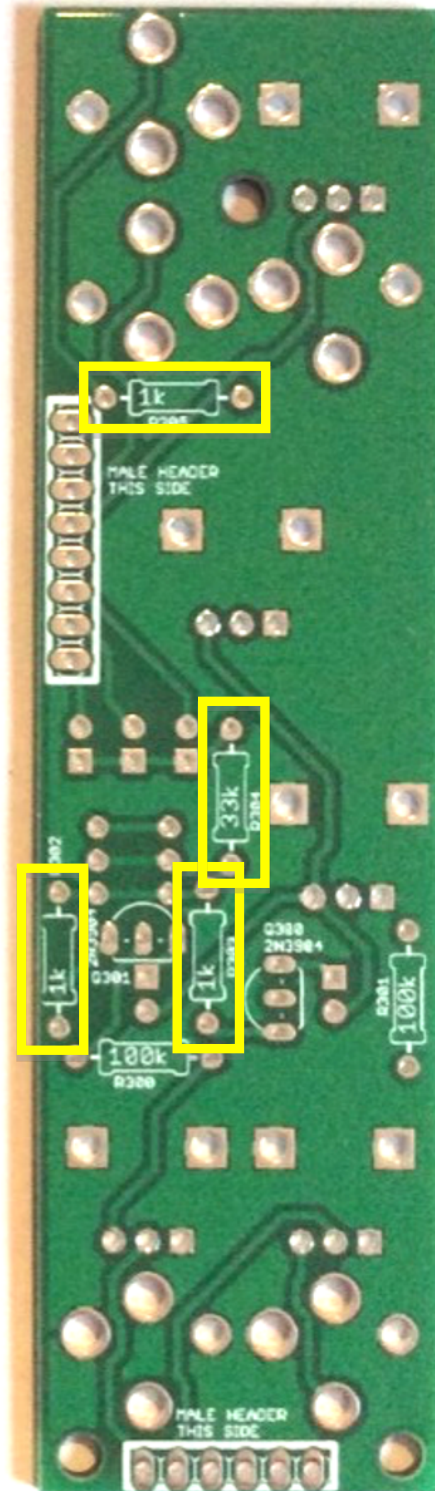

1) – 4 x 1k (R302, R303, R304, R305)

Note: On some PCBs from 2021 and earlier - R304 states 33K on the PCB, but 1K is the correct value to use.

Outer Board 1K resistors

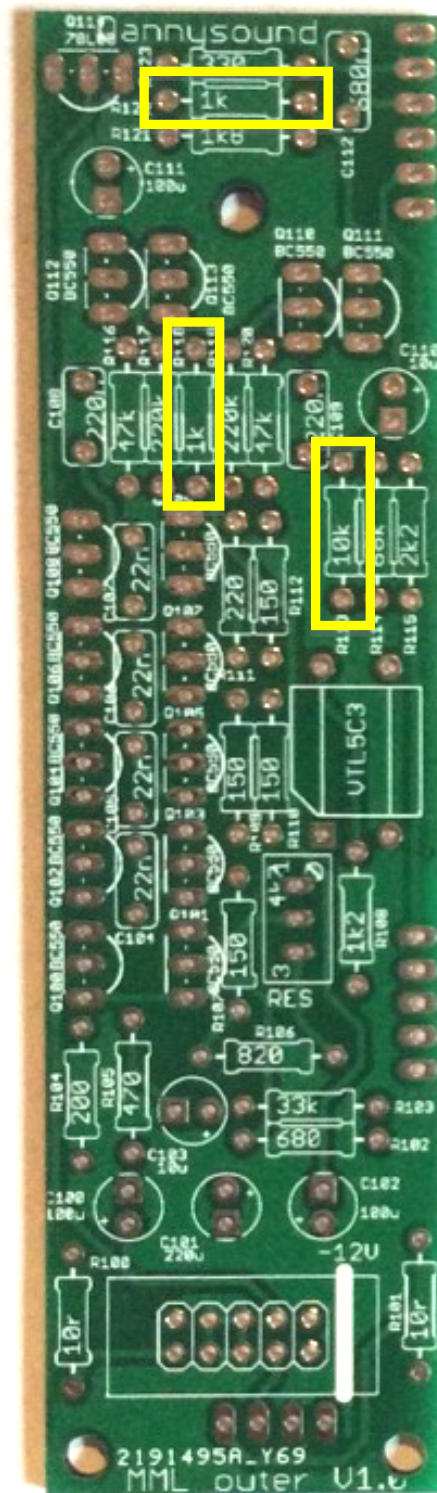

2) – 3 x 1k (R113, R118, R122)

Note: On some PCBs from 2021 and earlier - R113 states 10K on the PCB but 1K is correct

5 Outer Board

Now you can open the bag with the rest of the resistors inside

Locate the outer PCB

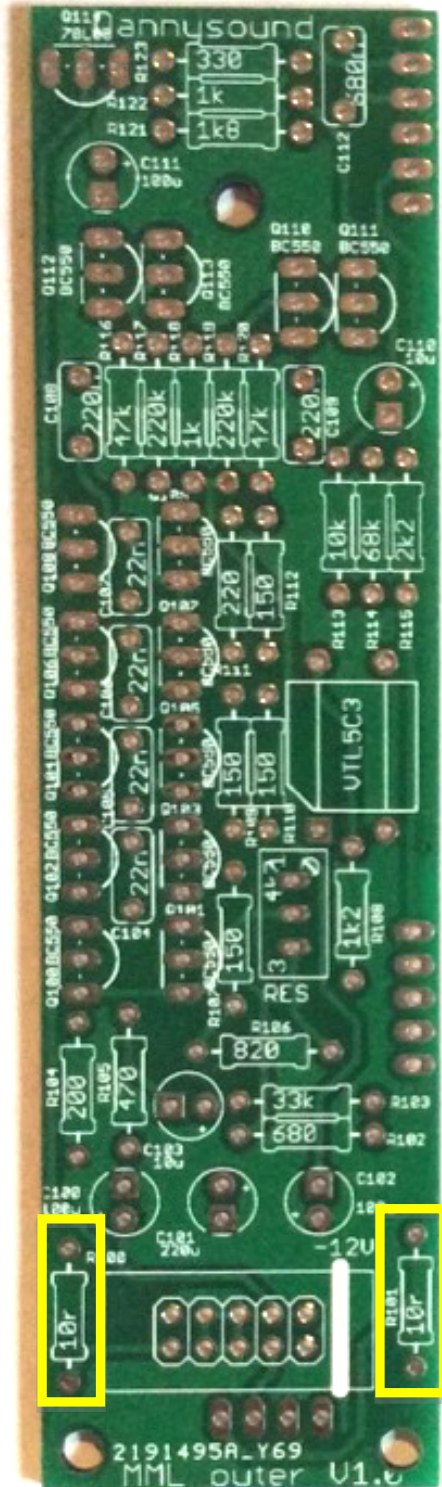

3) – 2 x 10r (R100, R101)

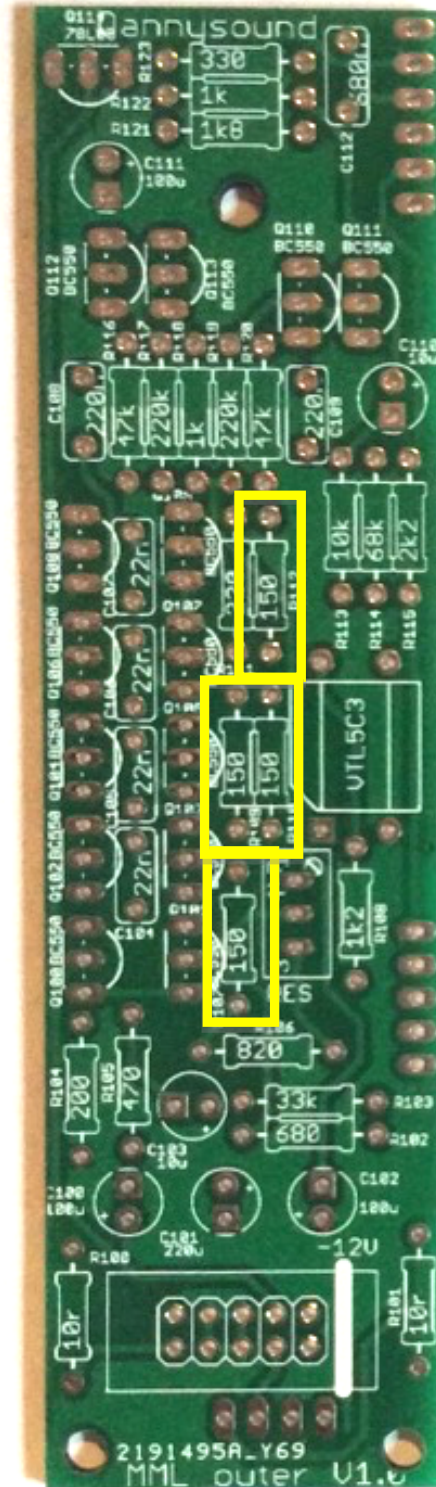

4) – 4 x 150r (R107, R109, R110, R112)

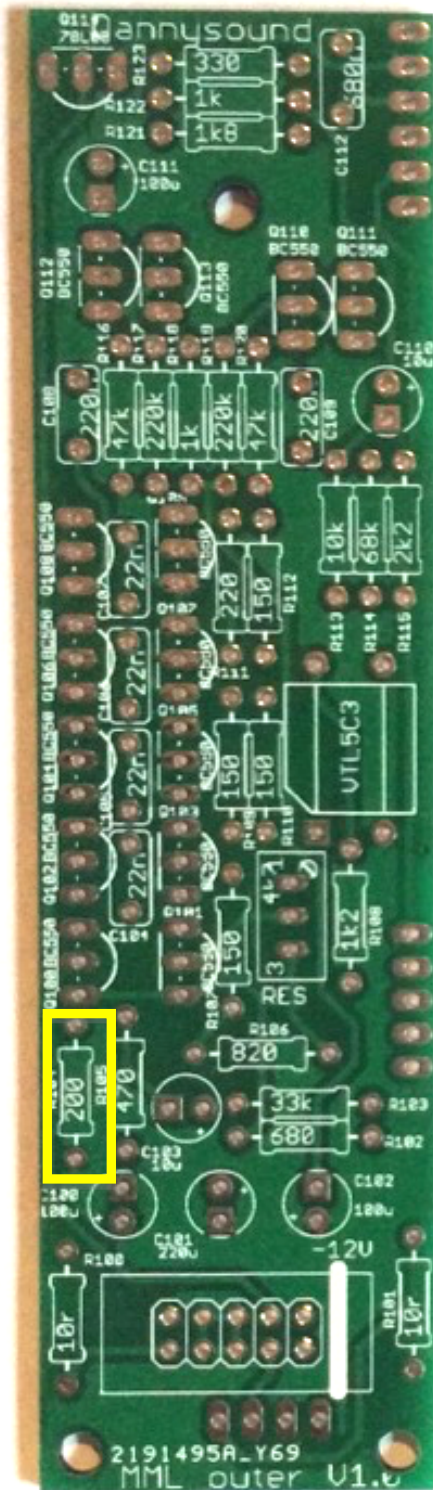

5) – 1 x 200r (R104)

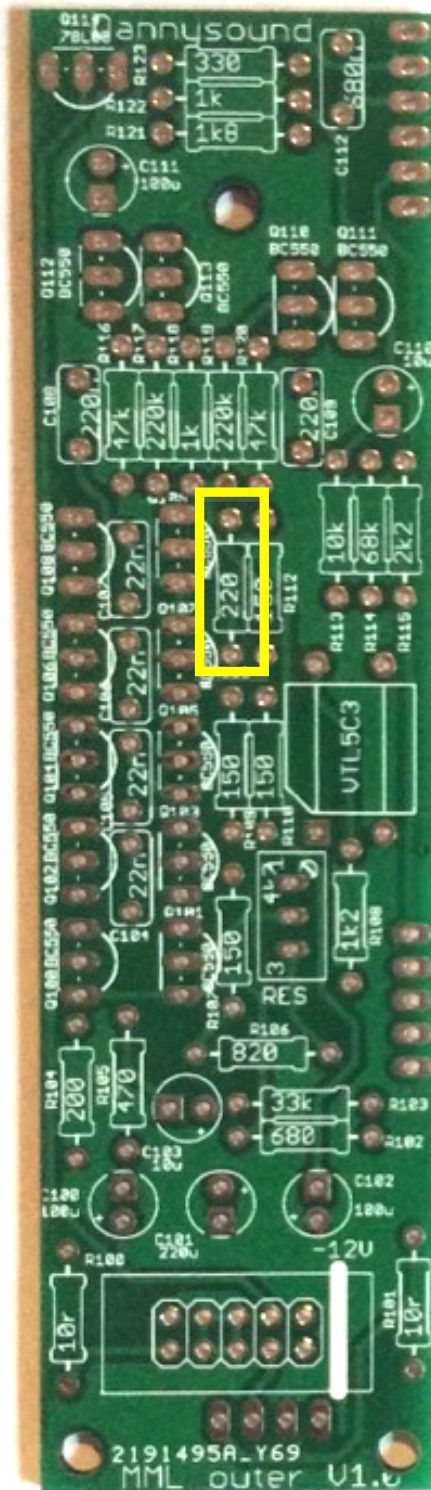

6) – 1 x 220r (R111)

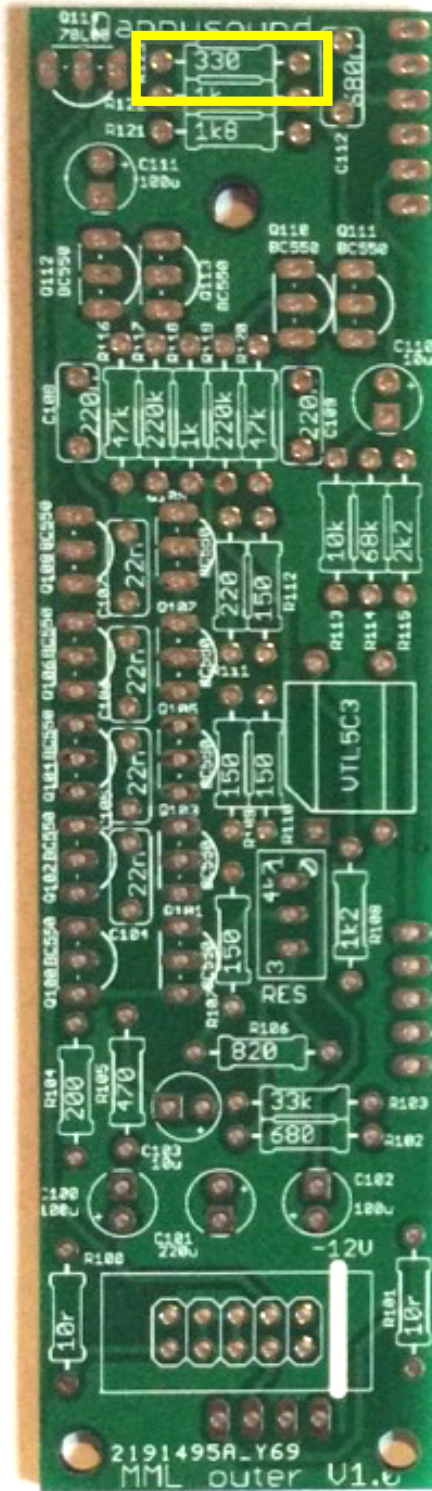

7) – 1 x 330r (R123)

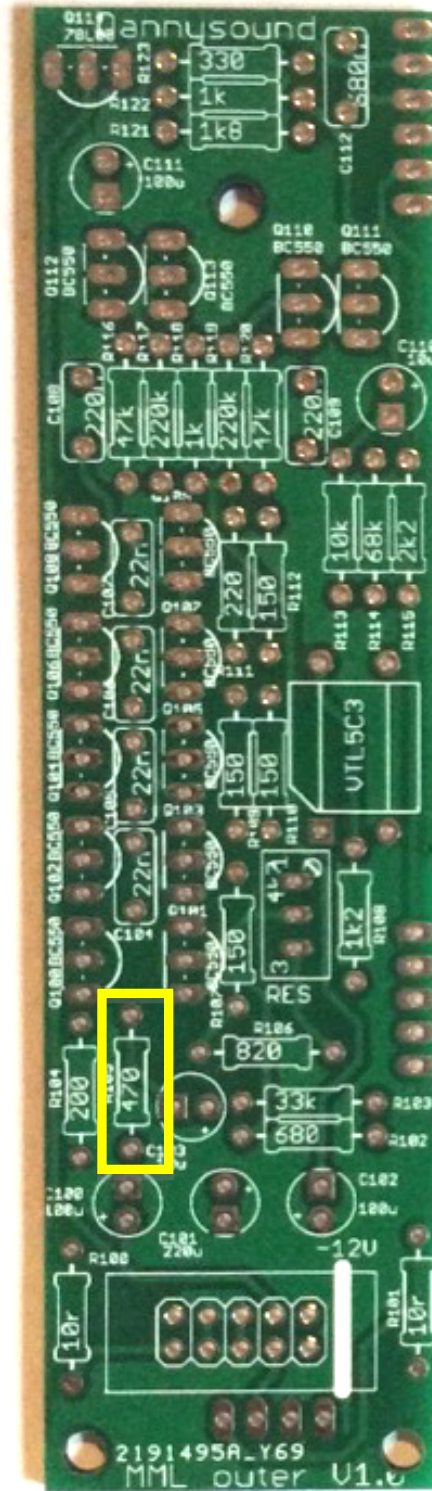

8) – 1 x 470r (R105)

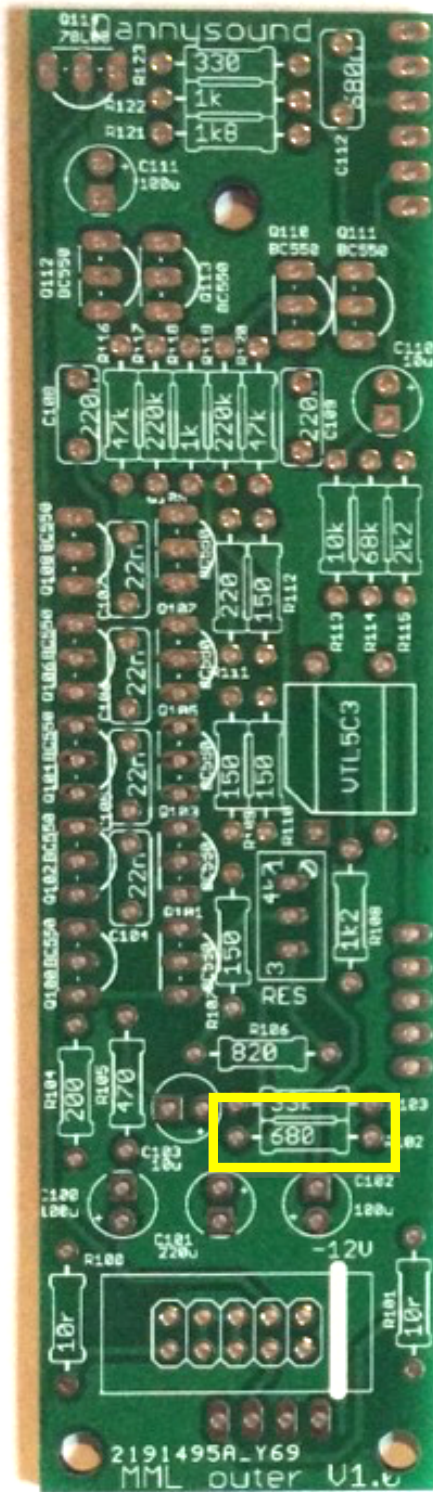

9) – 1 x 680r (R102)

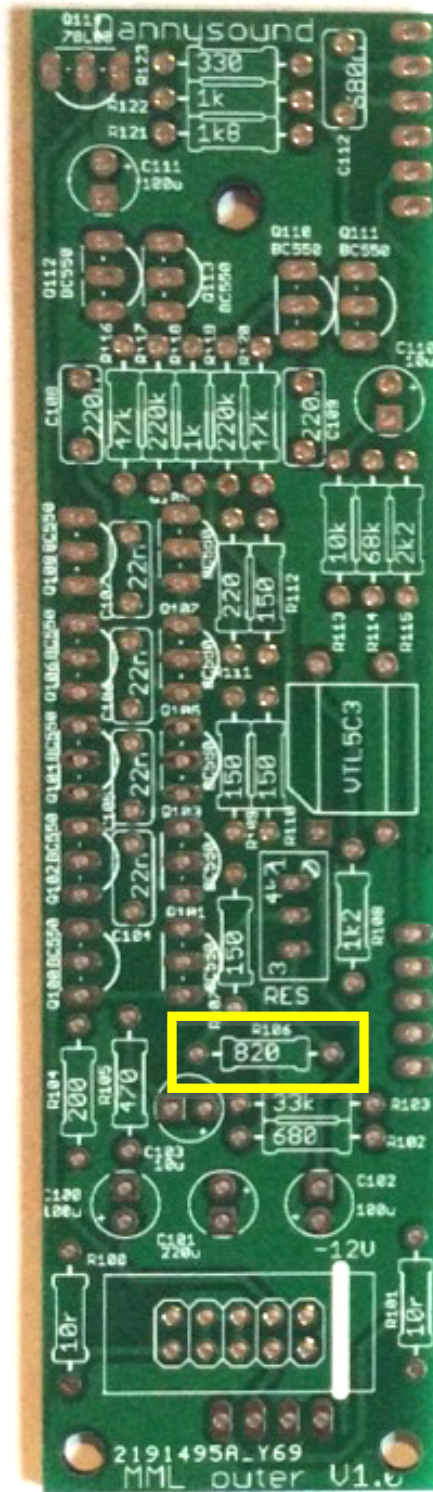

10) – 1 x 820r (R106)

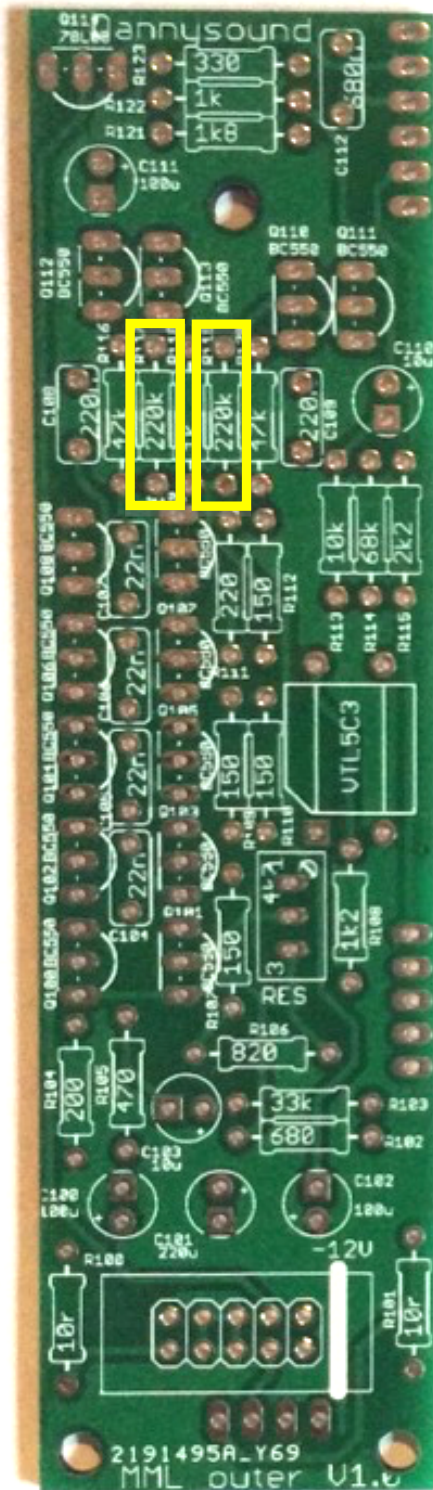

11) – 2 x 220k (R117, R119)

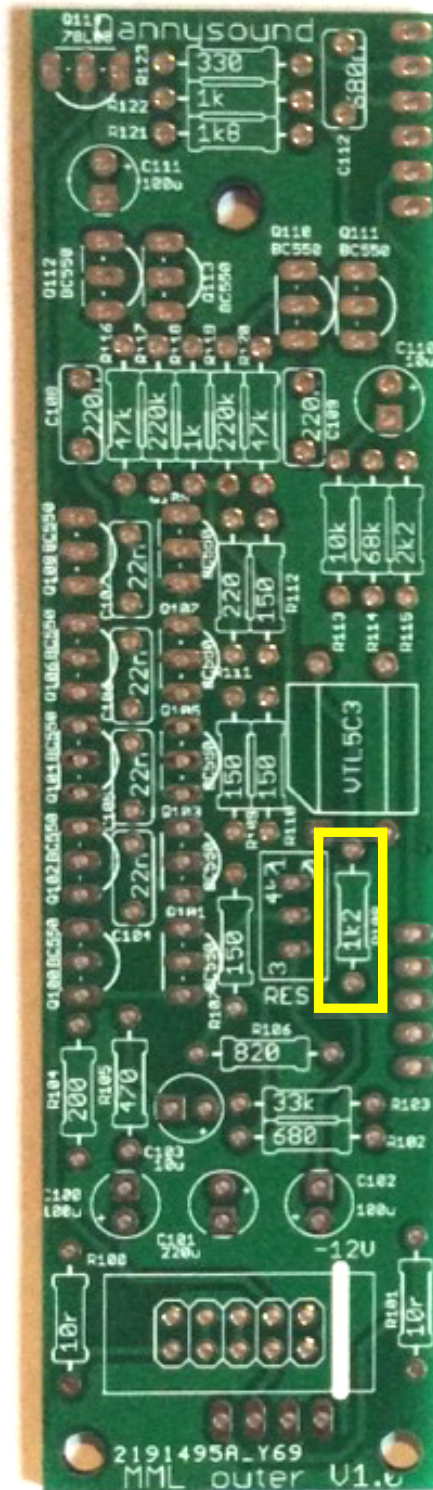

12) – 1 x 1k2 (R108)

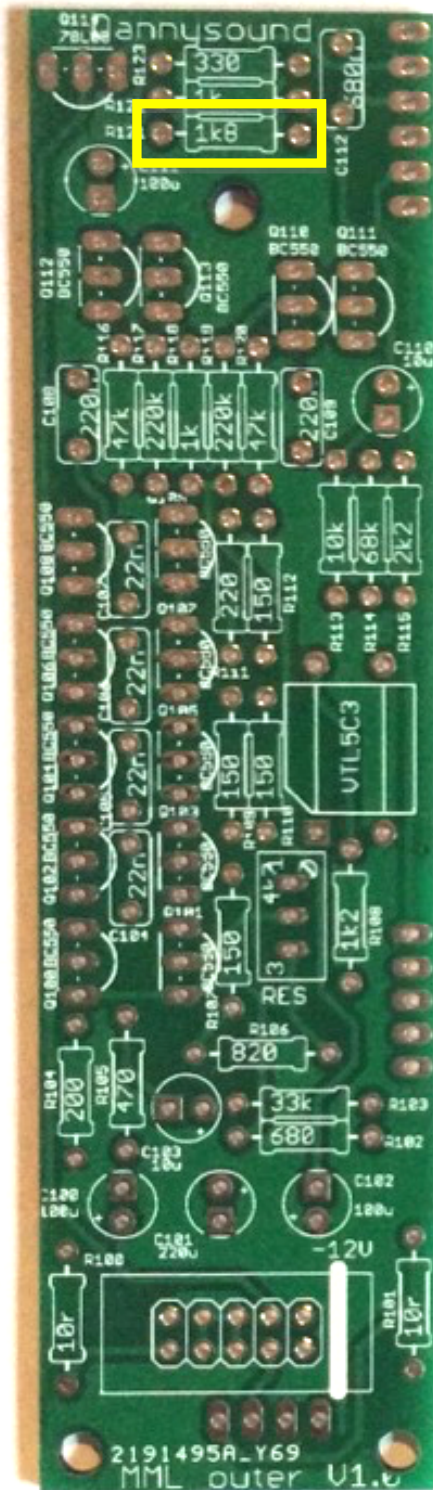

13) – 1 x 1k8 (R121)

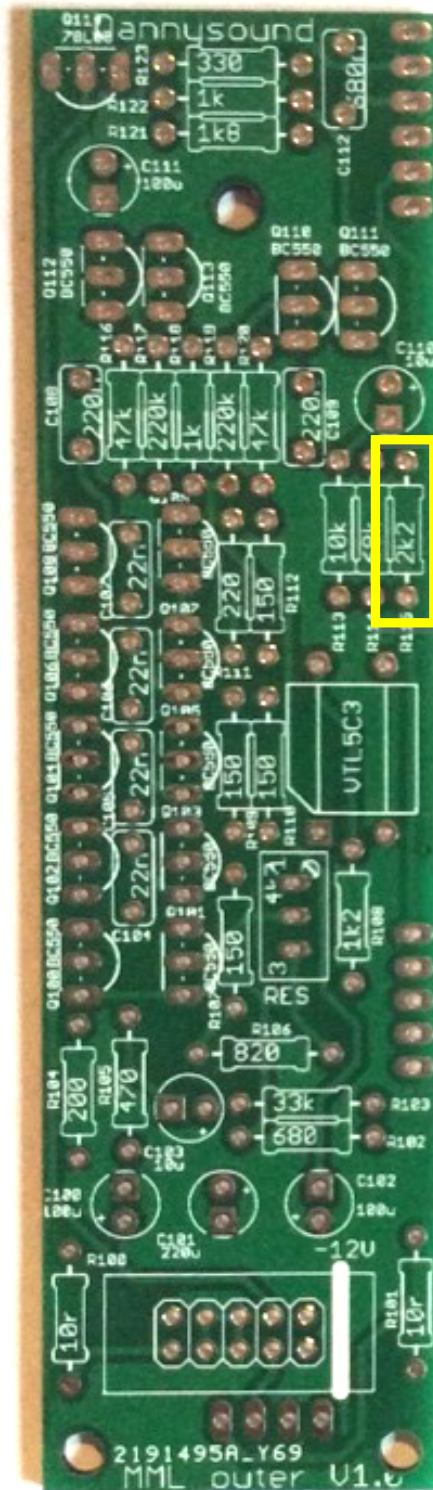

14) – 1 x 2k2 (R115)

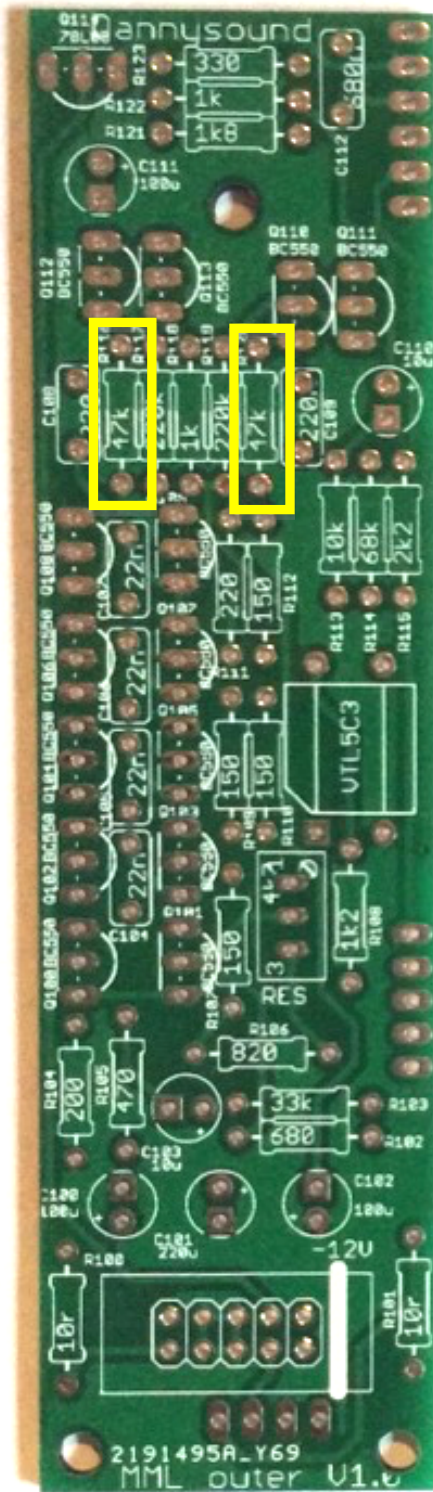

16) – 2 x 47k (R116, R120)

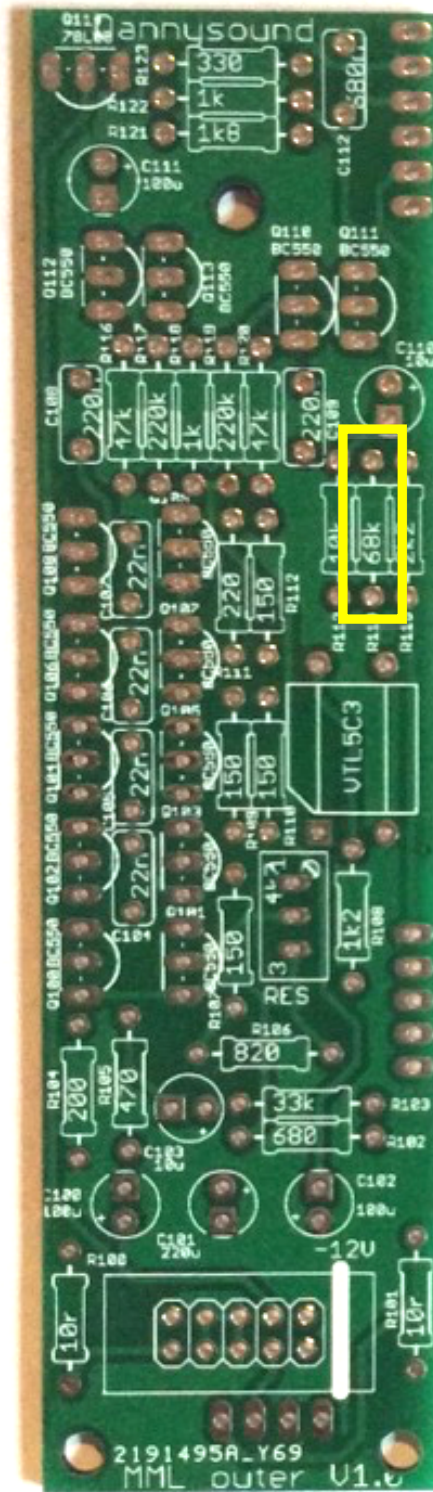

17) – 1 x 68k (R114)

CAPACITORS

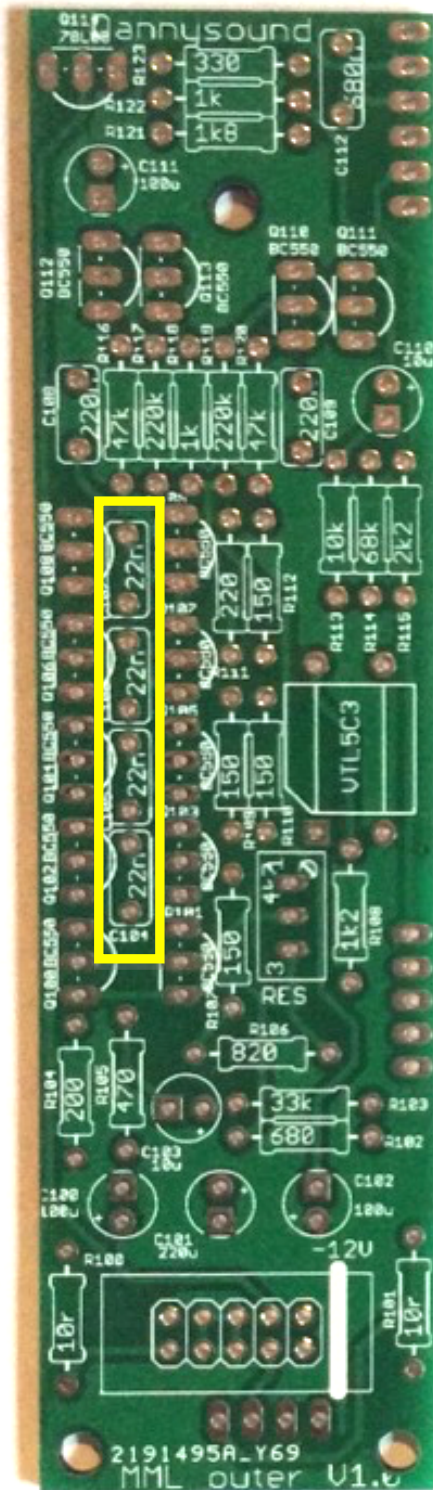

18) – 4 x 22n box caps
(C104, C105, C106, C107)

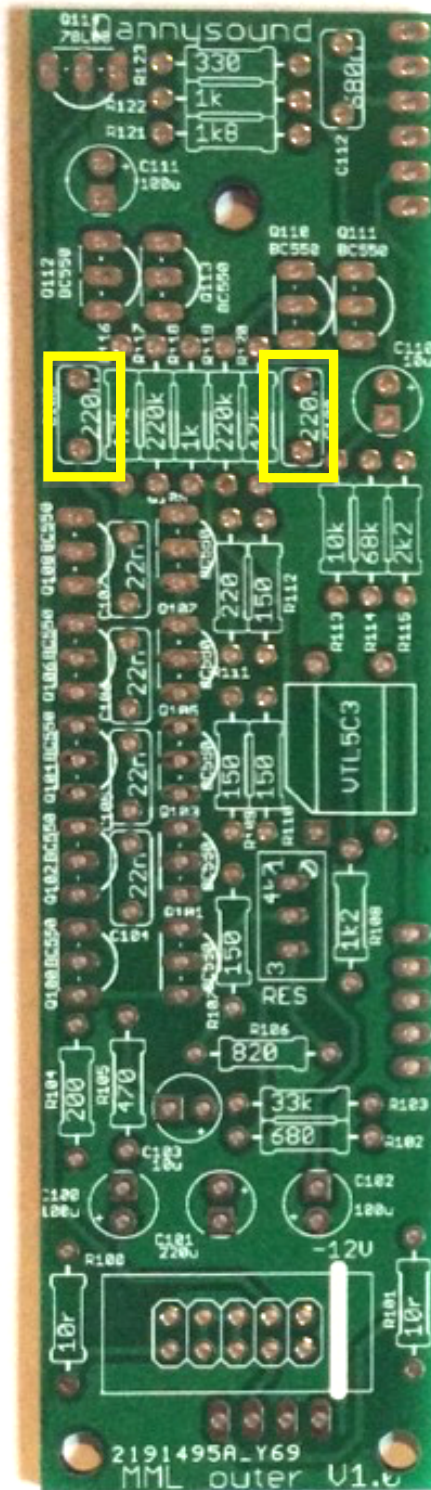

19) – 2 x 220n box caps
(C108, C109)

Note: these two values look very similar – be sure to check the part codes on the bag and correctly identify each part before placing.

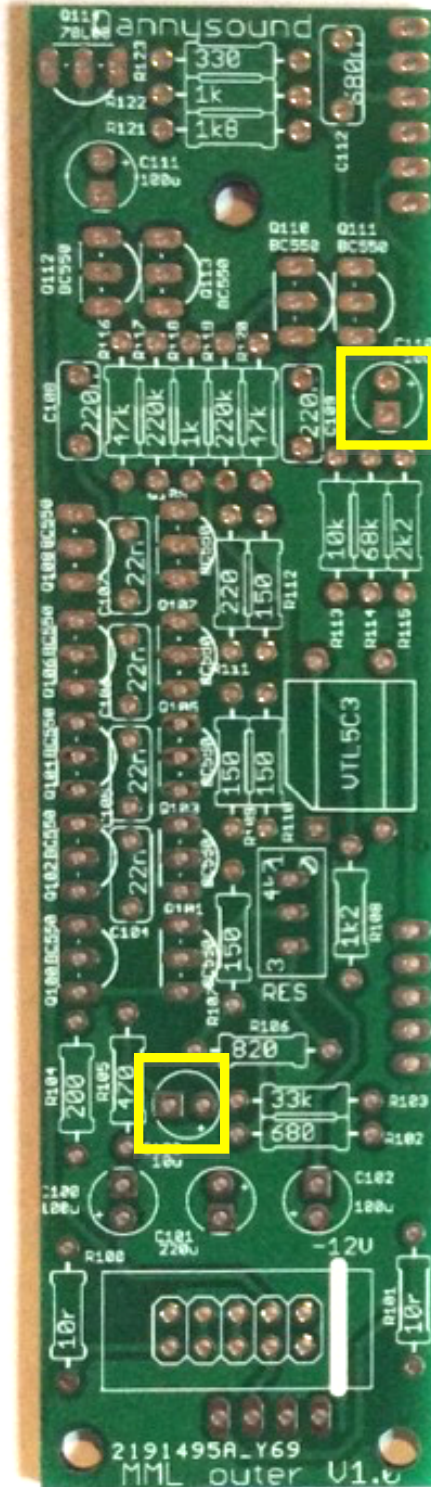
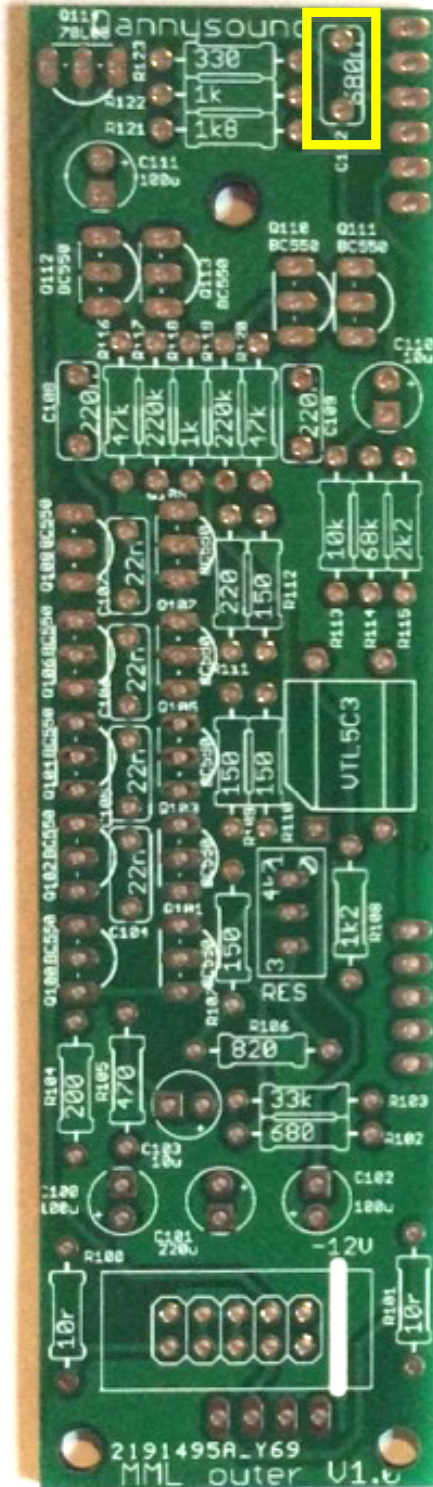

20) – 1 x 680n box cap (C112)

21) – 2 x 10u electro caps (C103, C110)

Note: mind polarity of the electro caps - the negative short lead should go to the square pad on the PCB

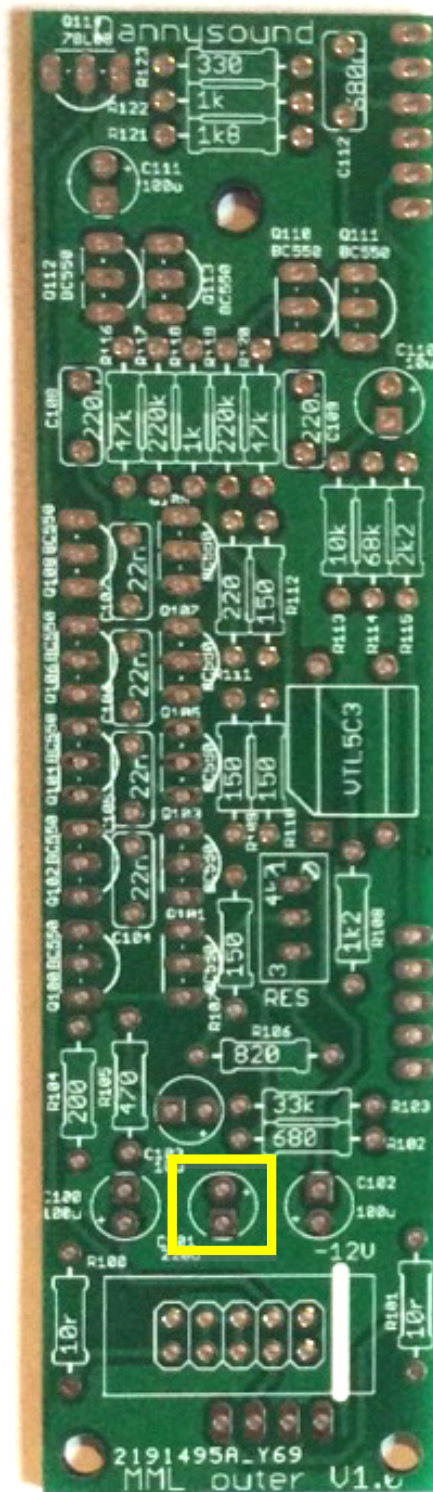
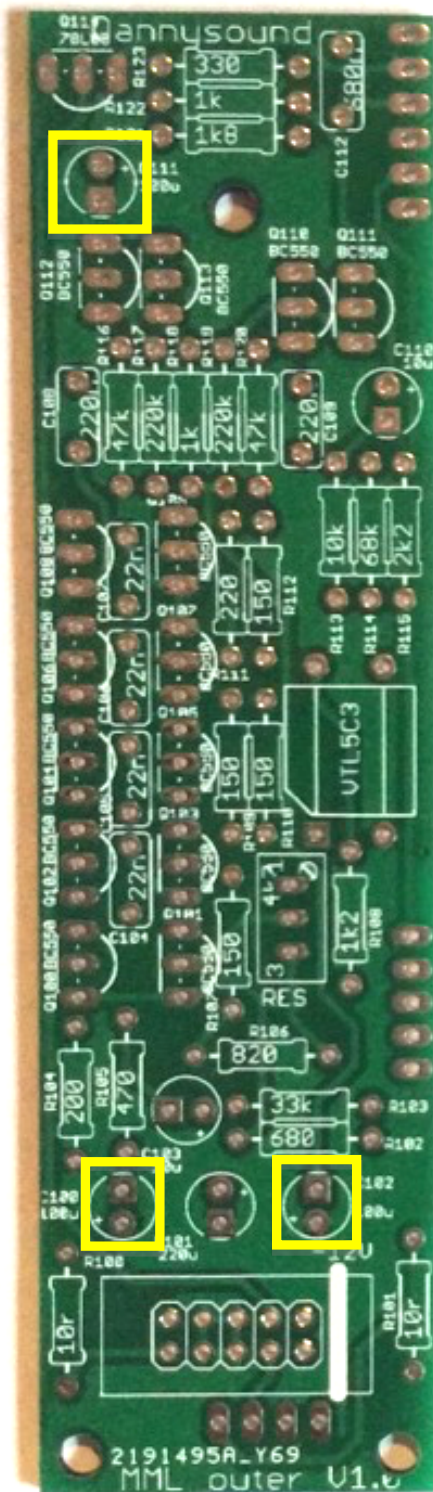

22) – 3 x 100u electro caps
(C111, C100, C102)

23) – 1 x 220u electro cap (C101)

Note: mind polarity - the negative short lead should go to the square pad on the PCB

TRANSISTORS

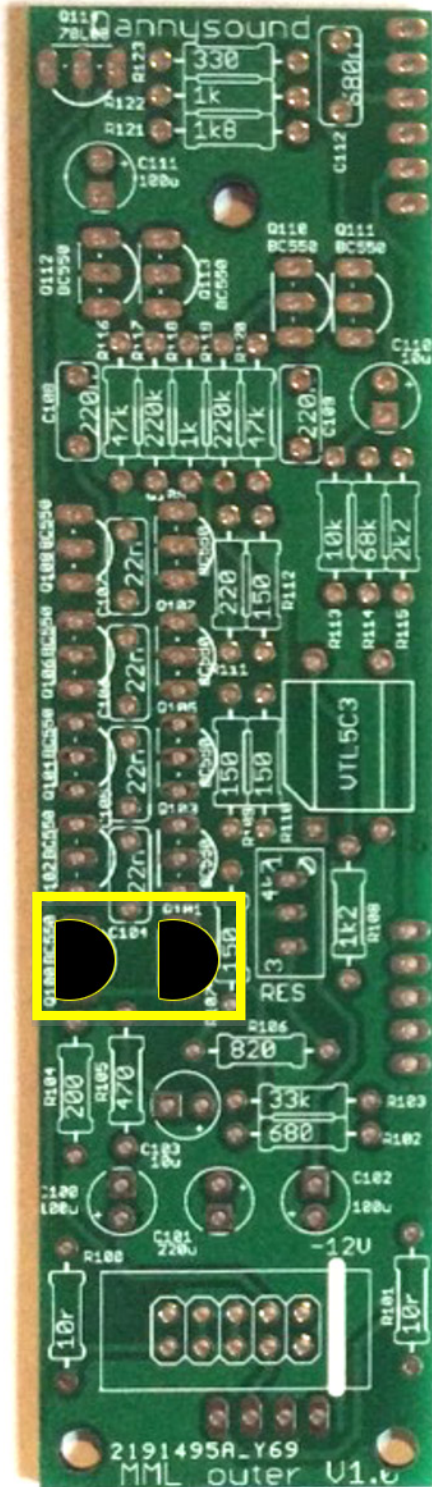

24) – BC550 MATCHED PAIR (Q100, Q101)

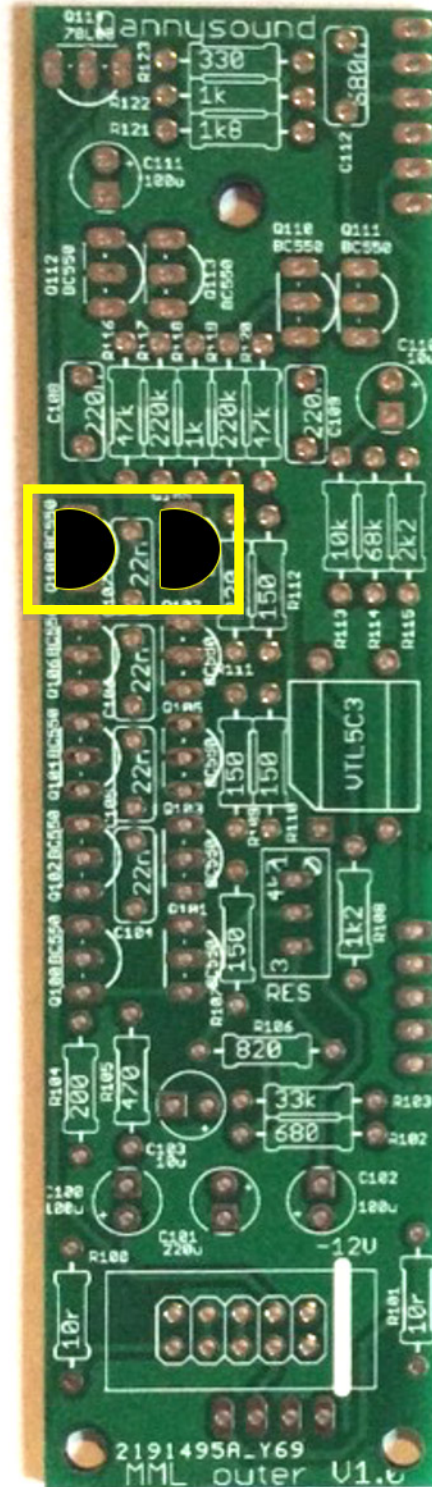

25) – BC550 MATCHED PAIR (Q108, Q109)

Note: BC550 matched pairs are located in the bag which contains the PCBs

--Do not confuse with 6 x unmatched transistors--

Note: mind polarity – match curve of each component with PCB silkscreen)

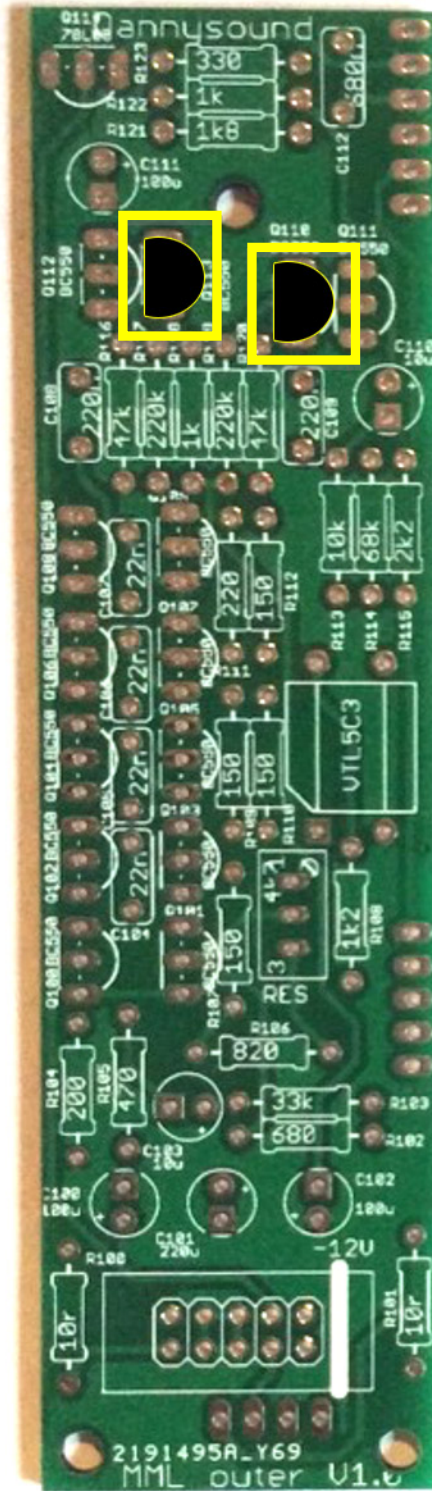
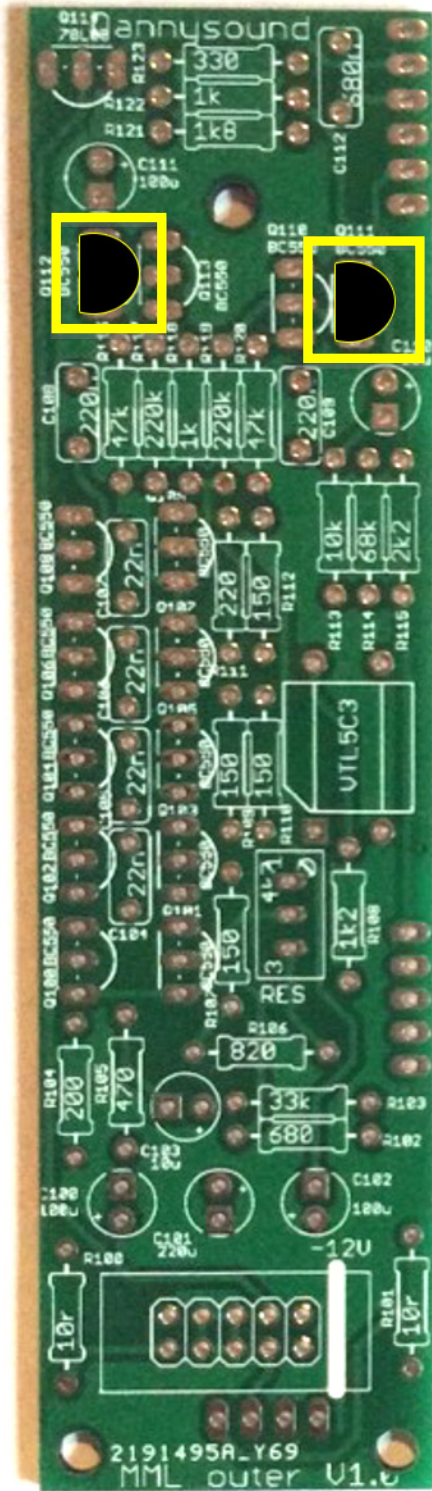

26) – BC550 MATCHED PAIR (Q112, Q111)

27) – BC550 MATCHED PAIR (Q113, Q110)

Note: BC550 matched pairs are located in the bag which contains the PCBs,
--Do not confuse with 6 x unmatched transistors--
Note: mind polarity – match curve of each component with PCB silkscreen)

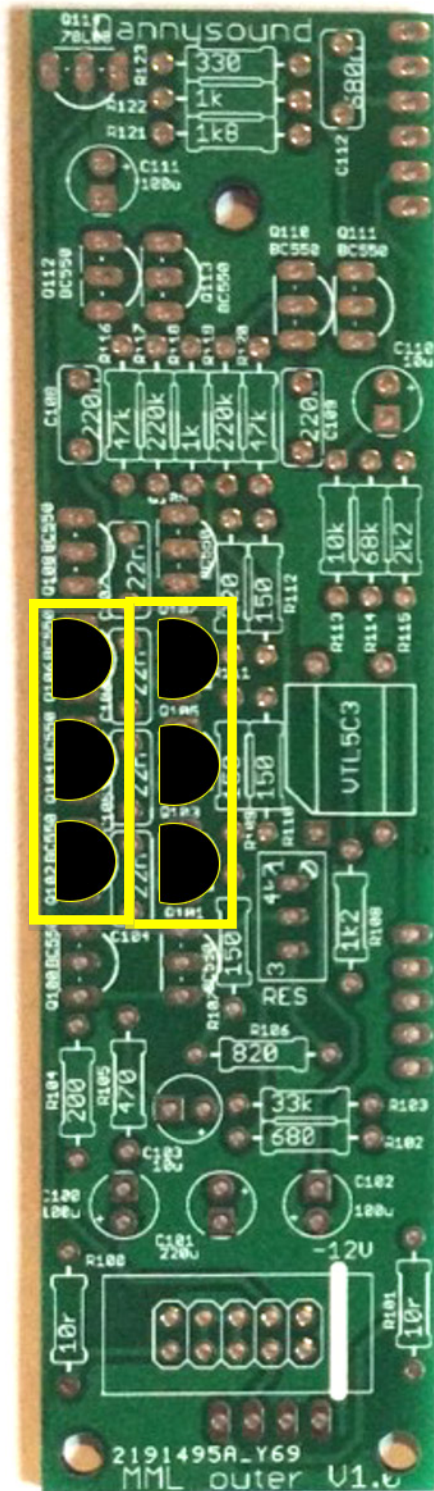

28) – 6 x BC550 (NOT MATCHED)

(Q102, Q103, Q104, Q105, Q106, Q107)

Note: Do not use matched pairs here

Note: mind polarity – match curve of each component with PCB silkscreen)

VOLTAGE REGULATOR AND VACTROL

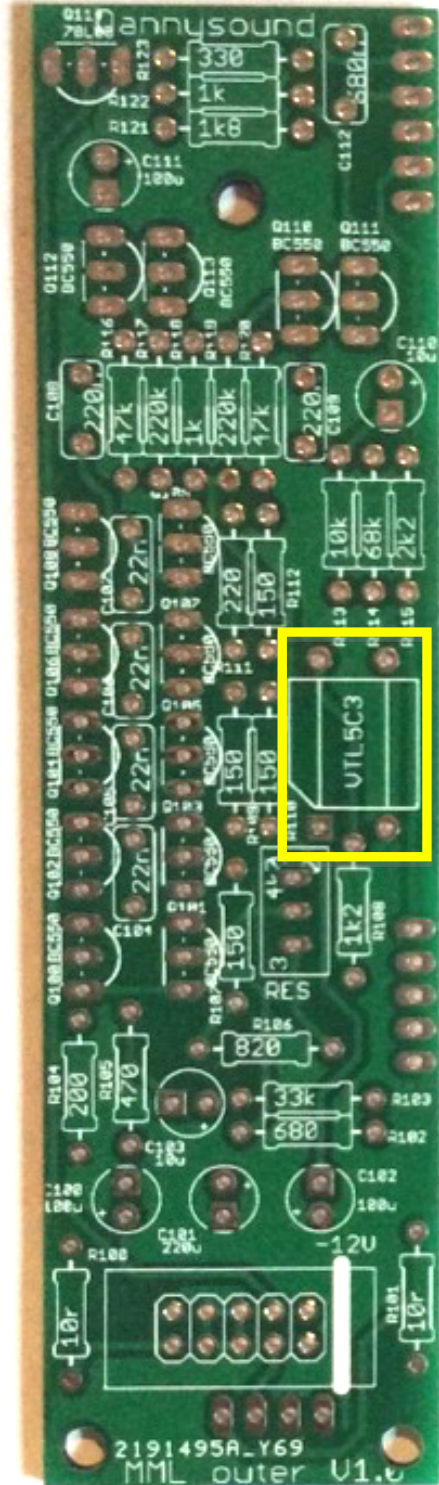
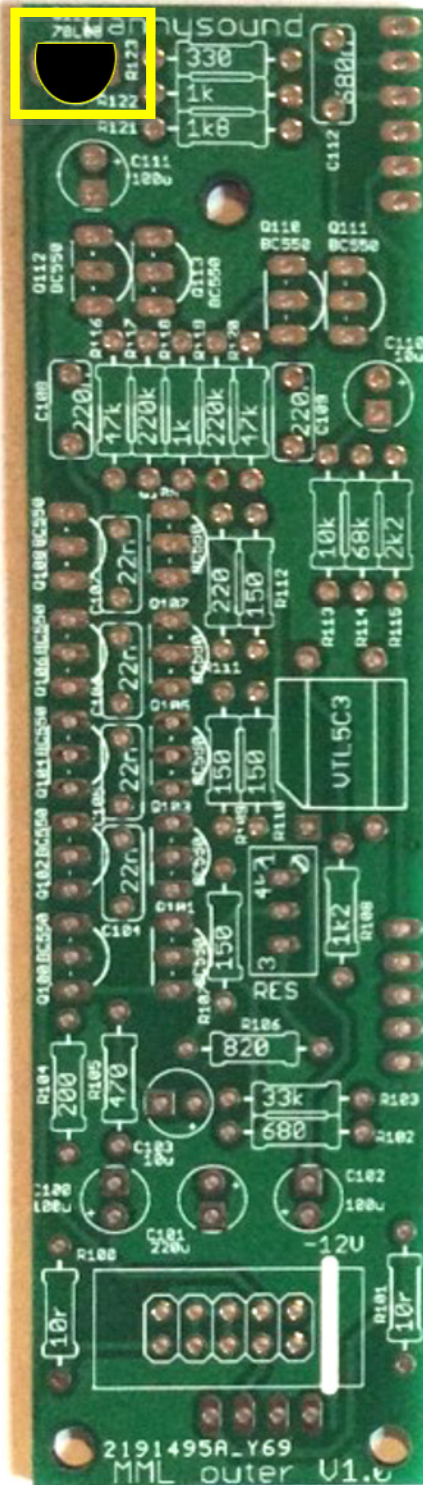

29) – 1 x 78L05 (Q114)

30) – 1 x VTL5C3 Vactrol

Note: mind polarity for both parts – match curve of 78L05 with PCB silkscreen. Match the slanted corner of the vactrol with the slant on the PCB silkscreen.

TRIMPOT AND POWER SOCKET

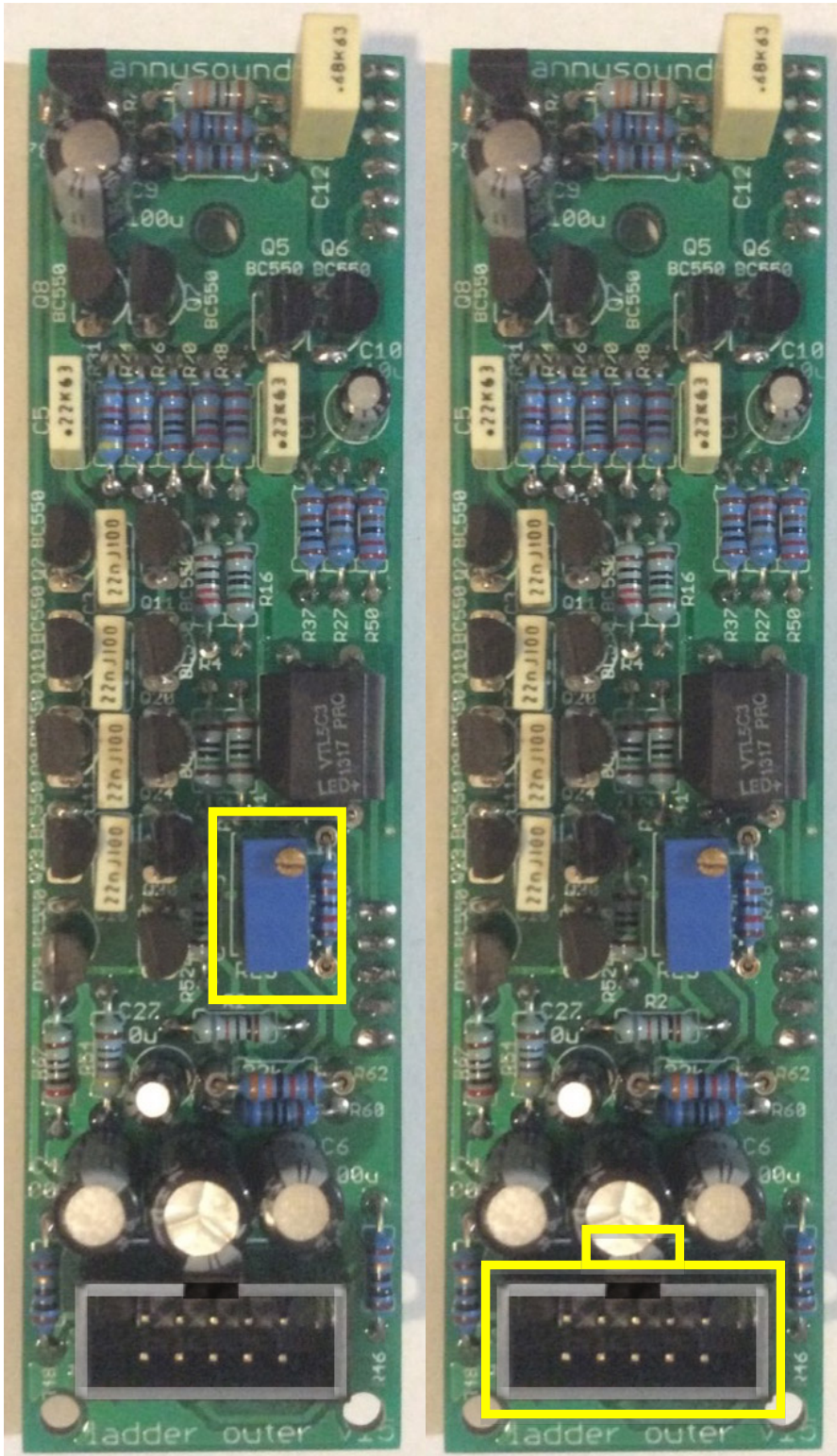

31) – 1 x 5k Trimpot

32) – 1 x 2x5 POWER Header

Note: orientation of header is vital! Be sure that the slot faces away from the edge of the PCB as indicated above.

FEMALE HEADERS

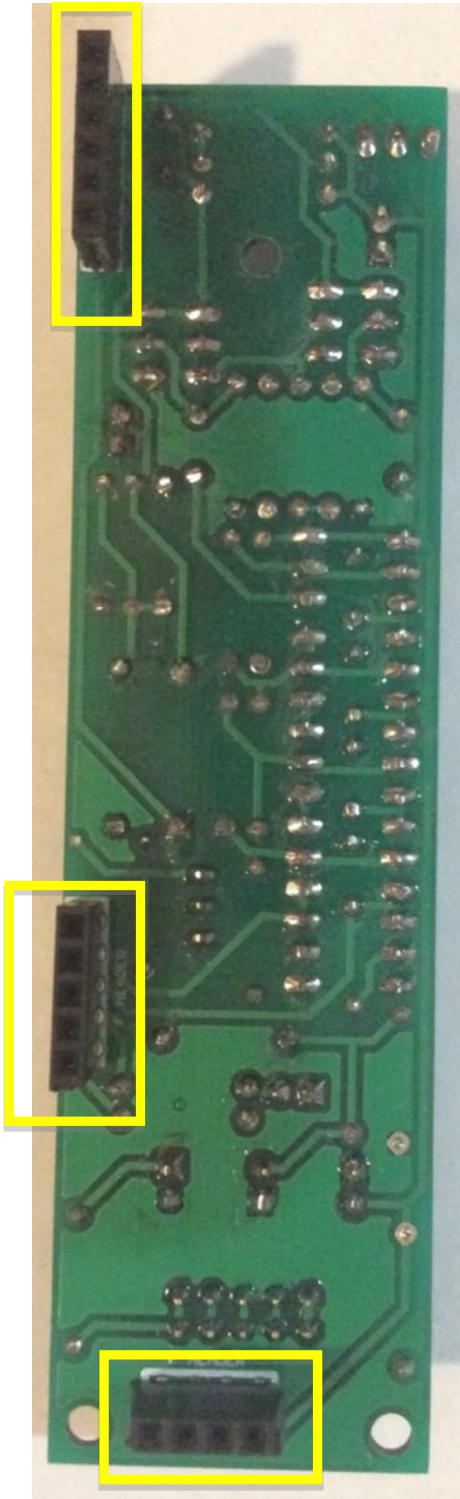

33) – 3 x FEMALE Headers

Note: these headers are placed on the opposite side to all previous components

How to cut female headers to size: <https://youtu.be/qDG3VFSMSPQ>

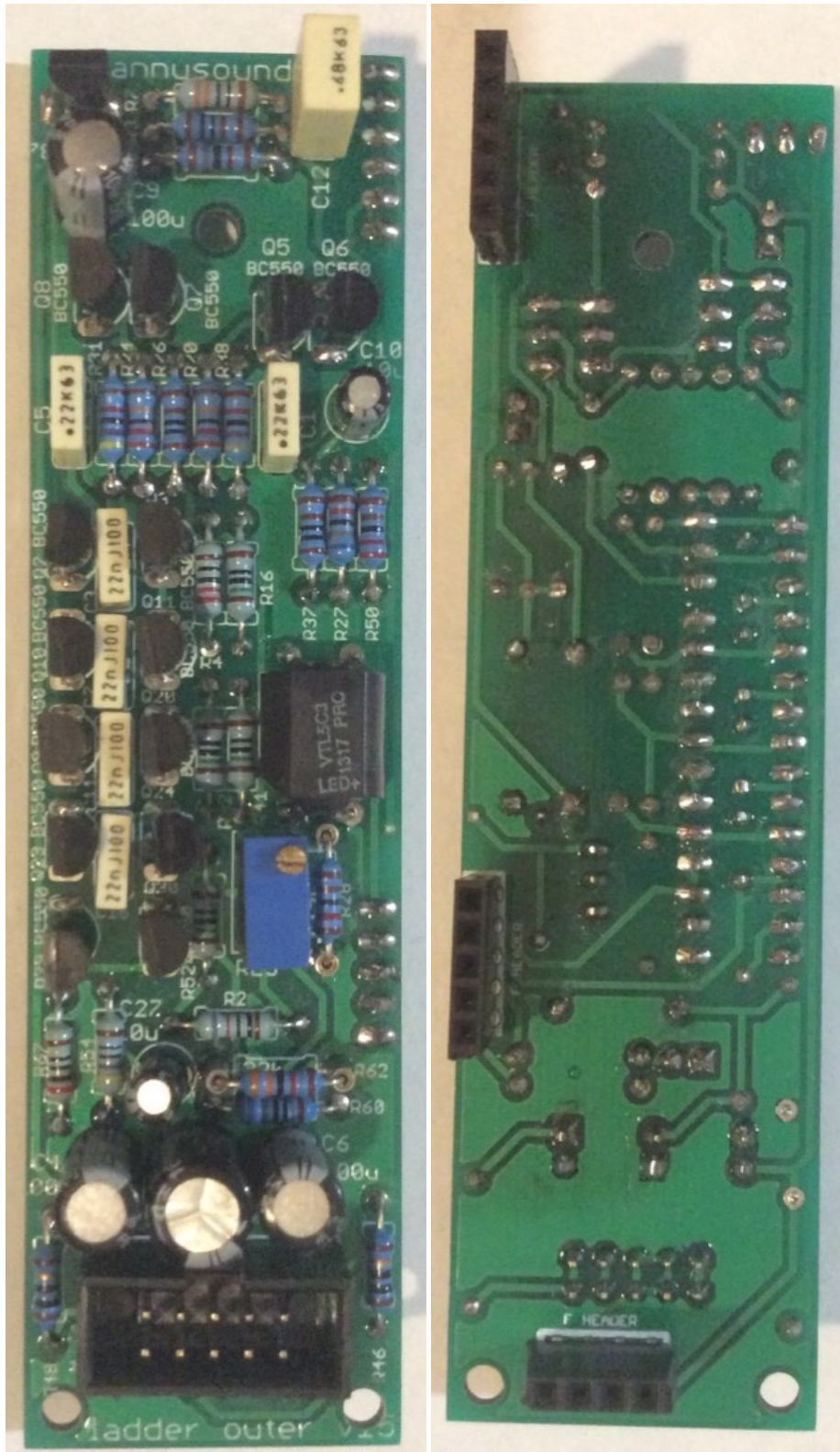

34) - The outer board is now complete!

6 Mid Board

DIODE and RESISTORS

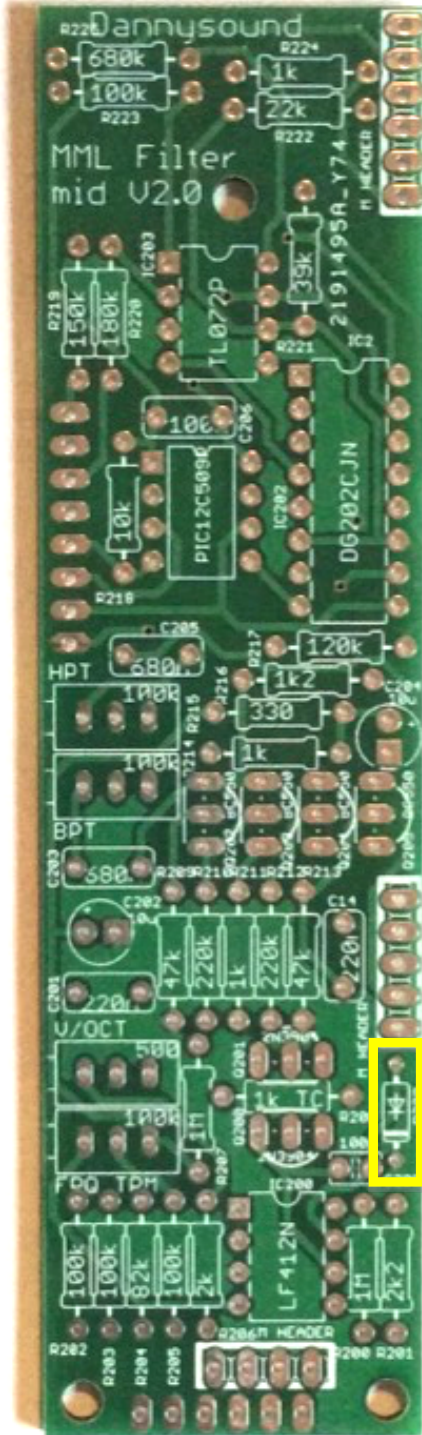

35) – 1 x 1N4148 diode (D200)

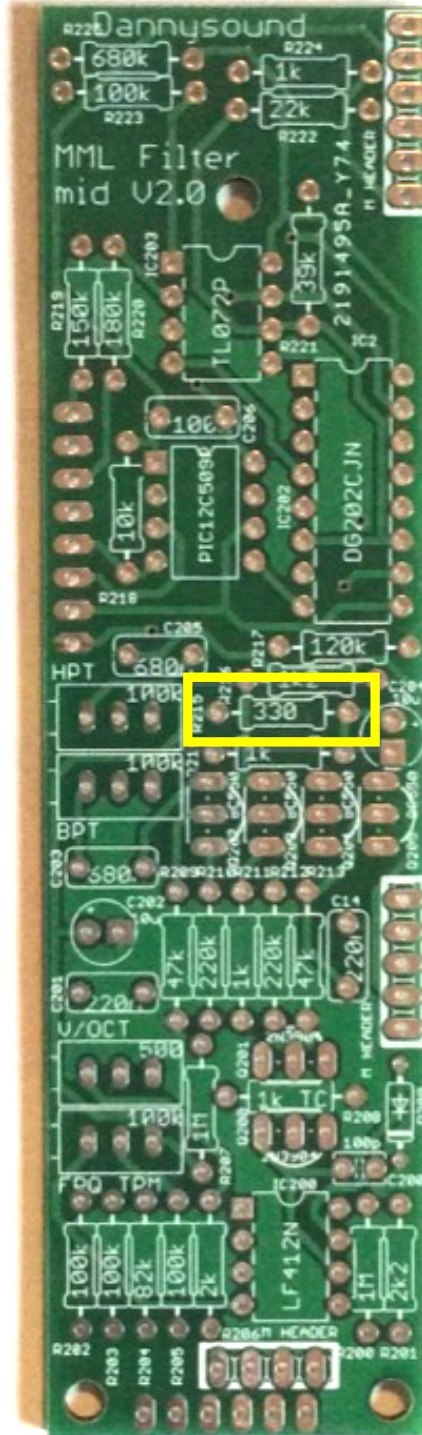

36) – 1 x 330r (R215)

Note: orientation of the diode is vital - be sure to match the line on the component with that on the PCB silkscreen

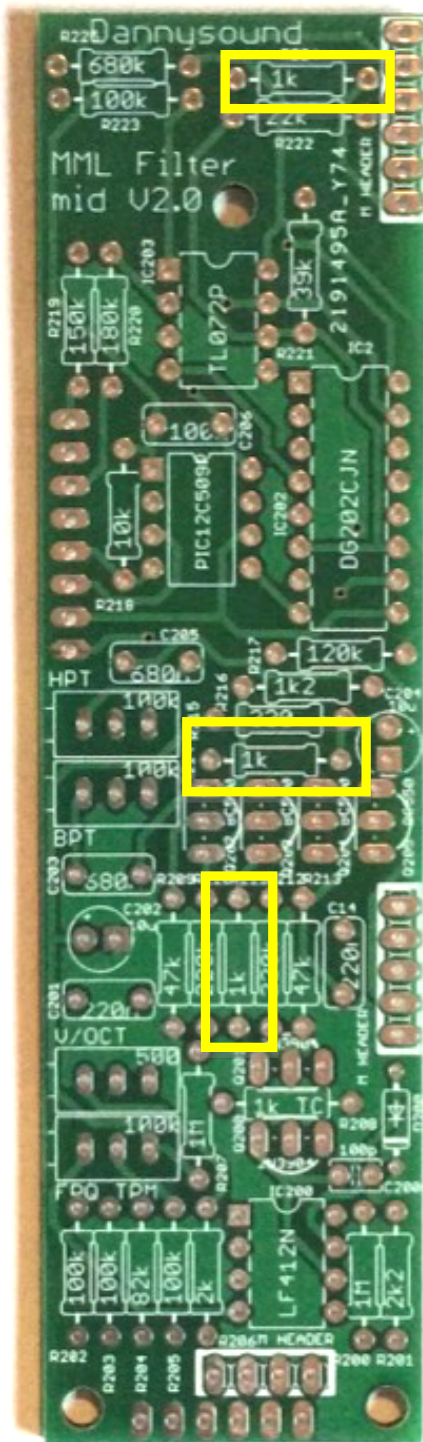

37) – 3 x 1k
(R211, R214, R224)

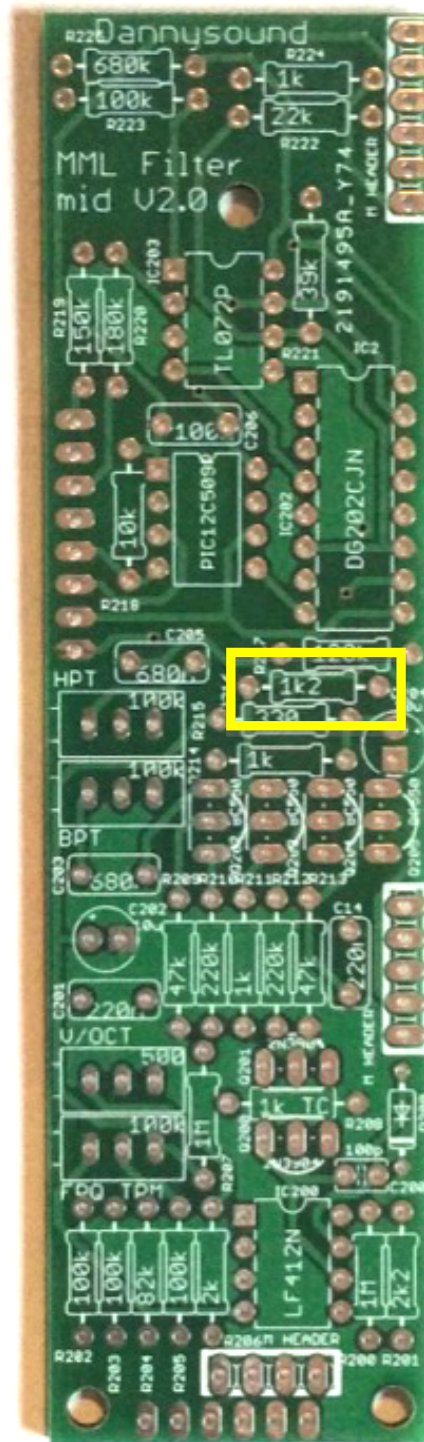

38) – 1 x 1k2 (R216)

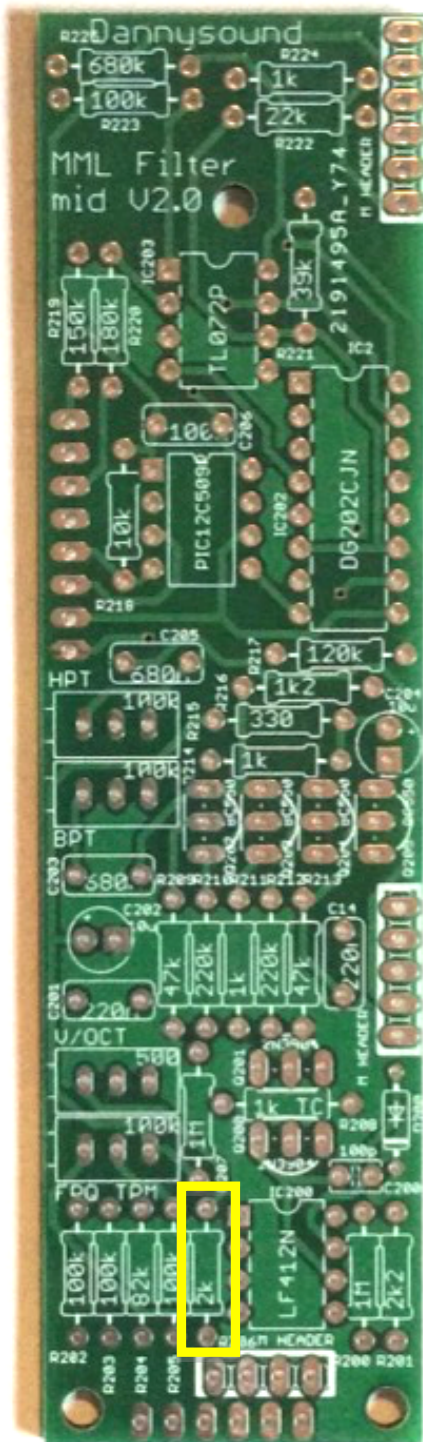

39) – 1 x 2k (R206)

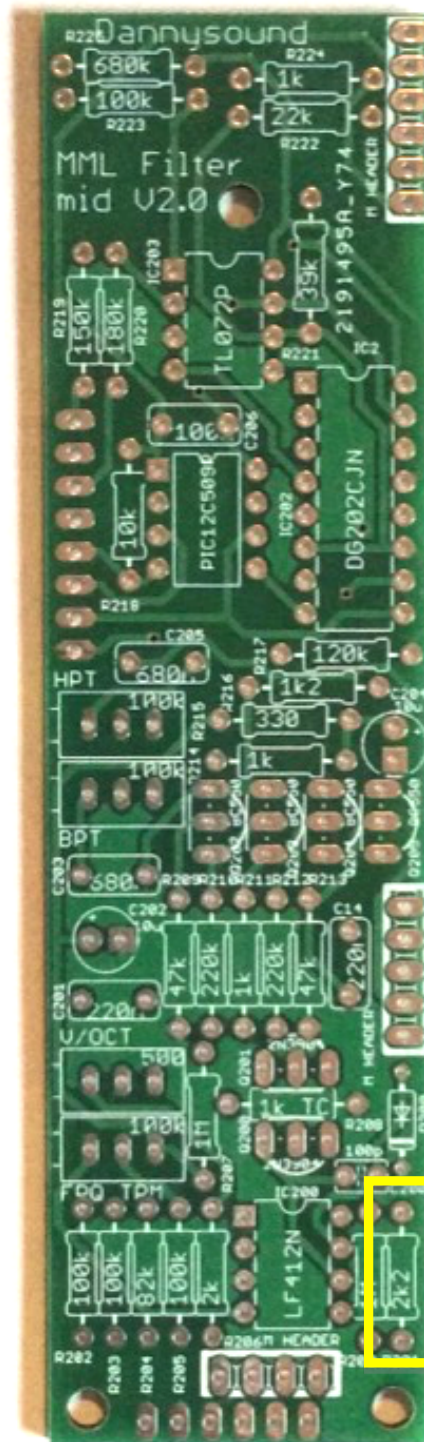

40) – 1 x 2k2 (R201)

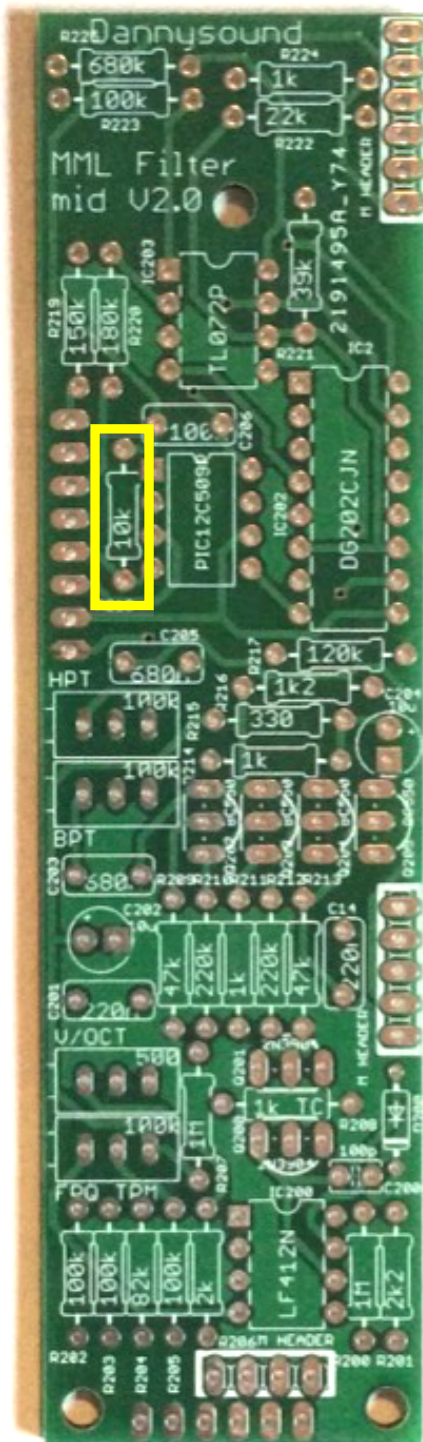

41) – 1 x 10k(R218)

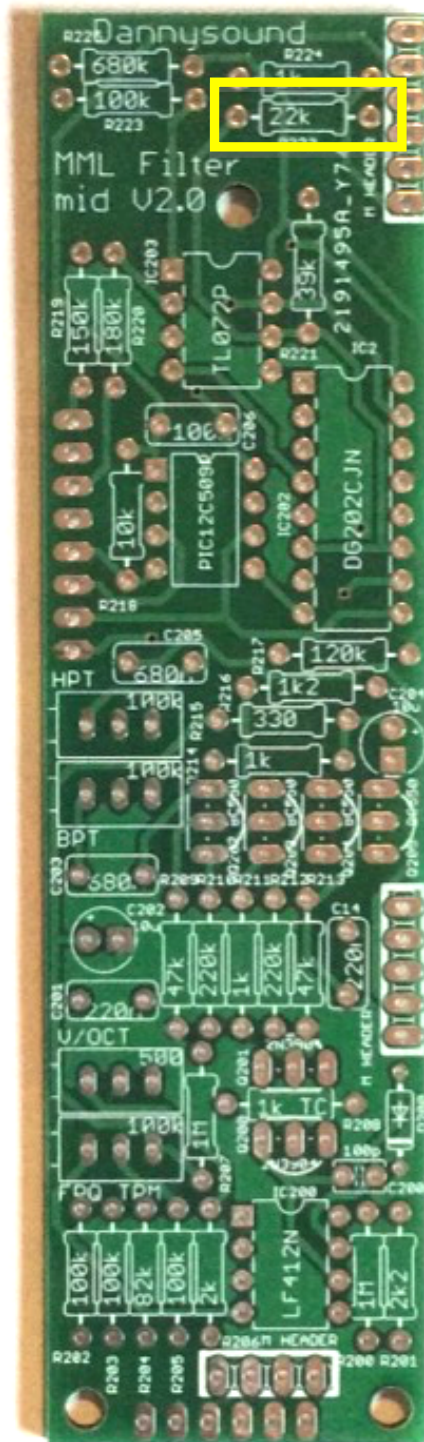

42) – 1 x 22k (R222)

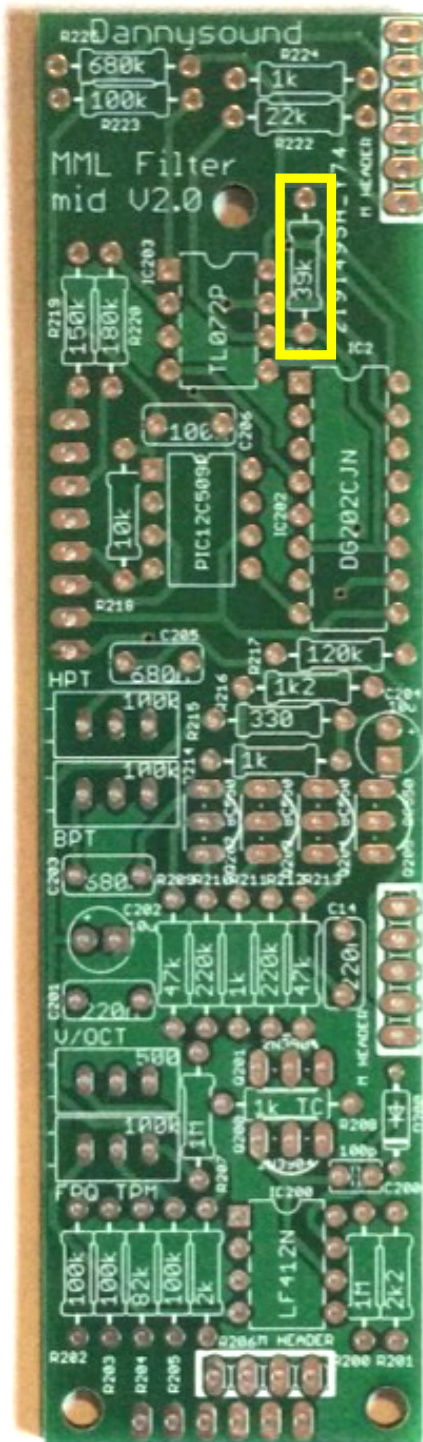

43) – 1 x 39k (R221)

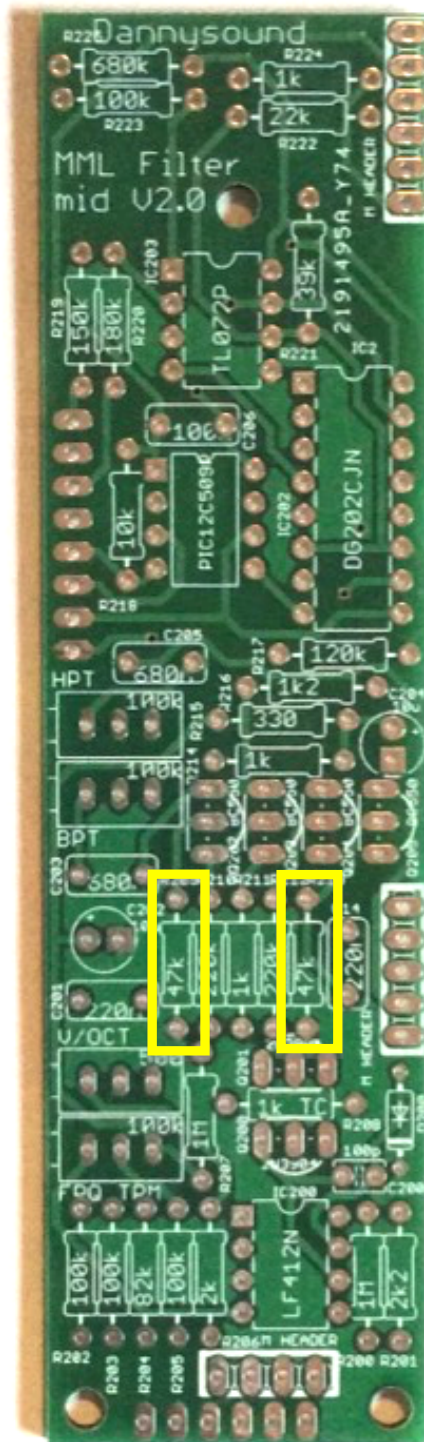

44) – 2 x 47k (R209, R213)

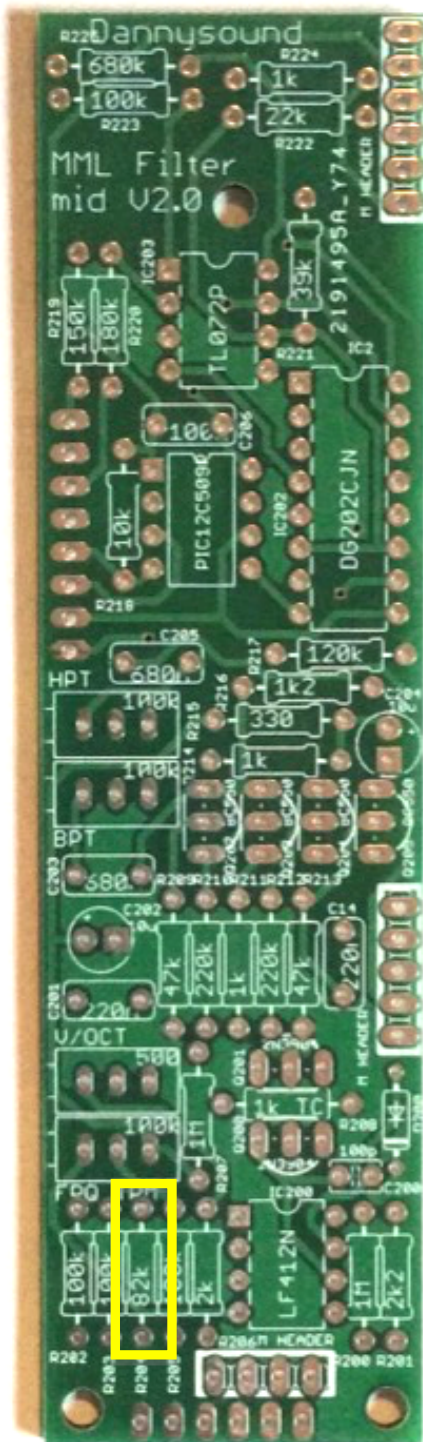

45) – 1 x 82k (R204)

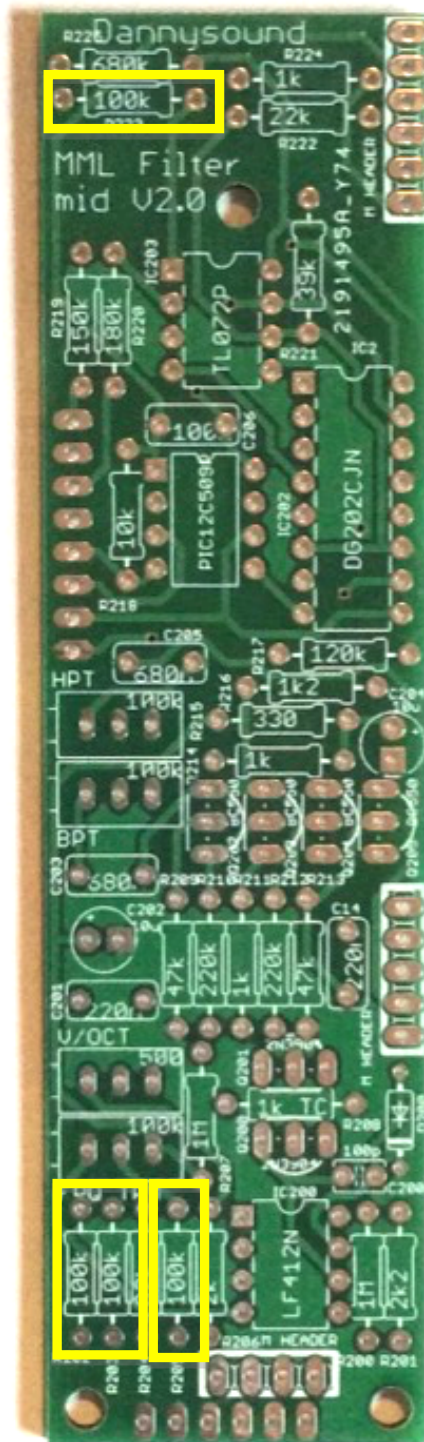

46) – 4 x 100k (R202, R203, R205, R223)

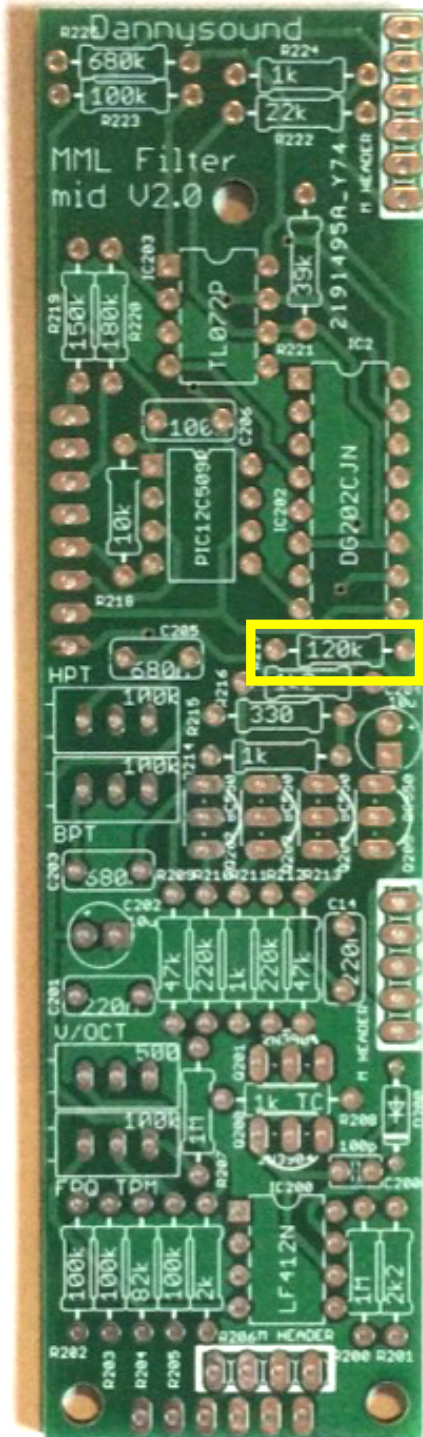

47) – 1 x 120k (R217)

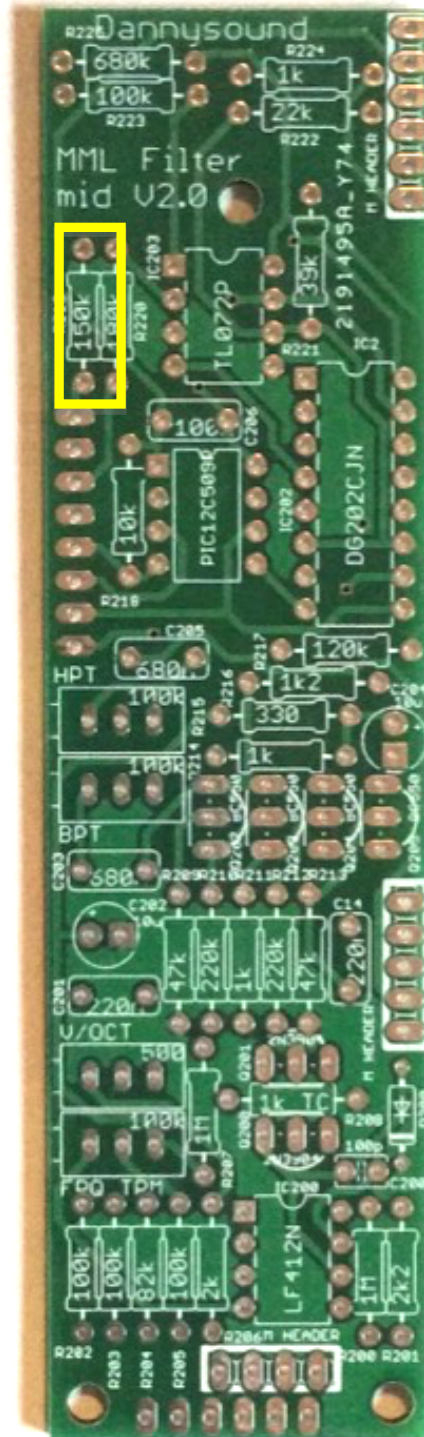

48) – 1 x 150k (R219)

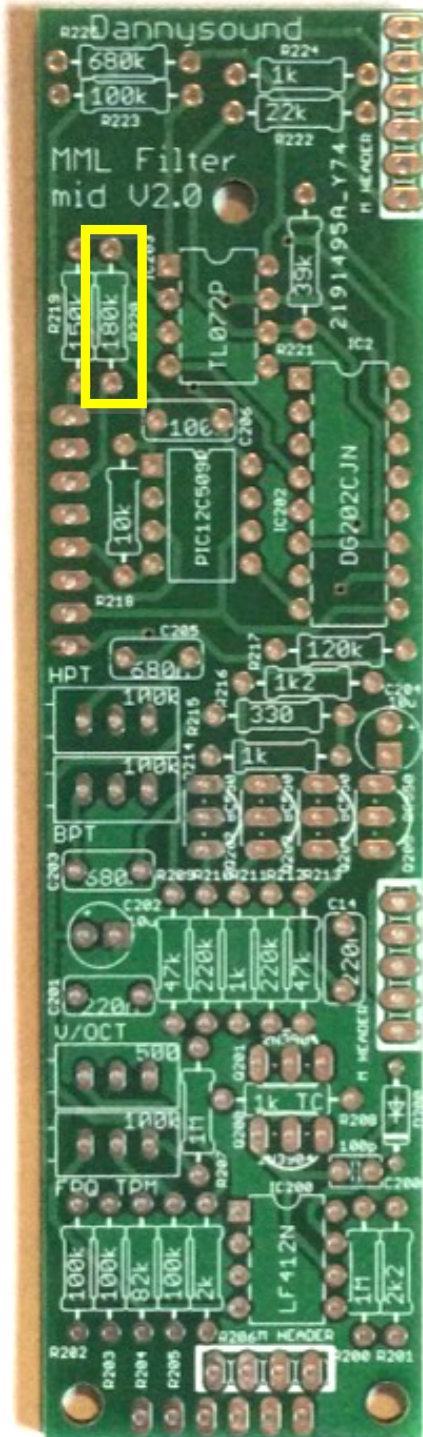

49) – 1 x 180k (R220)

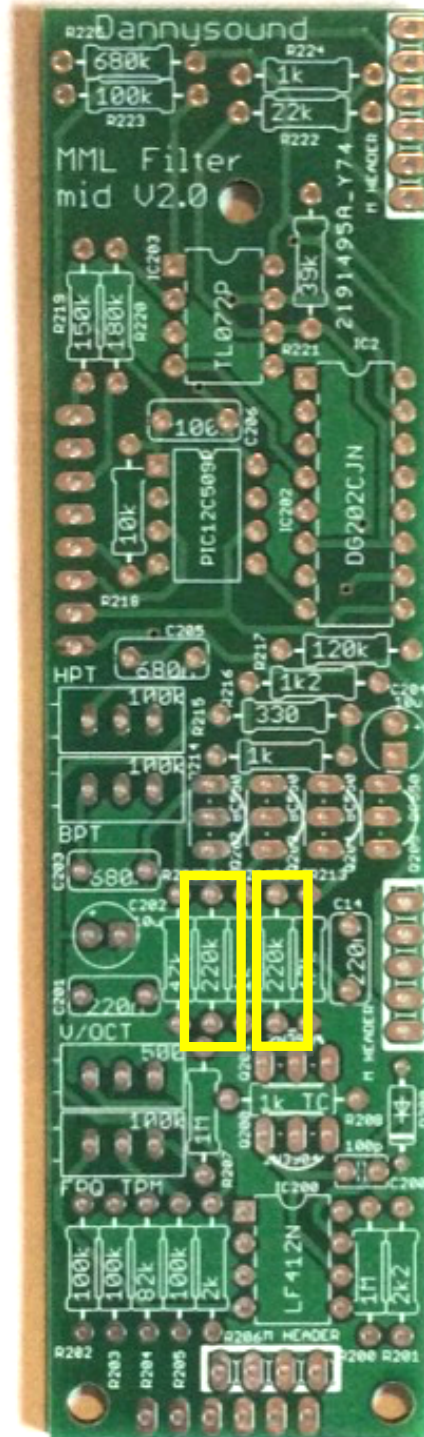

50) – 2 x 220k (R210, R212)

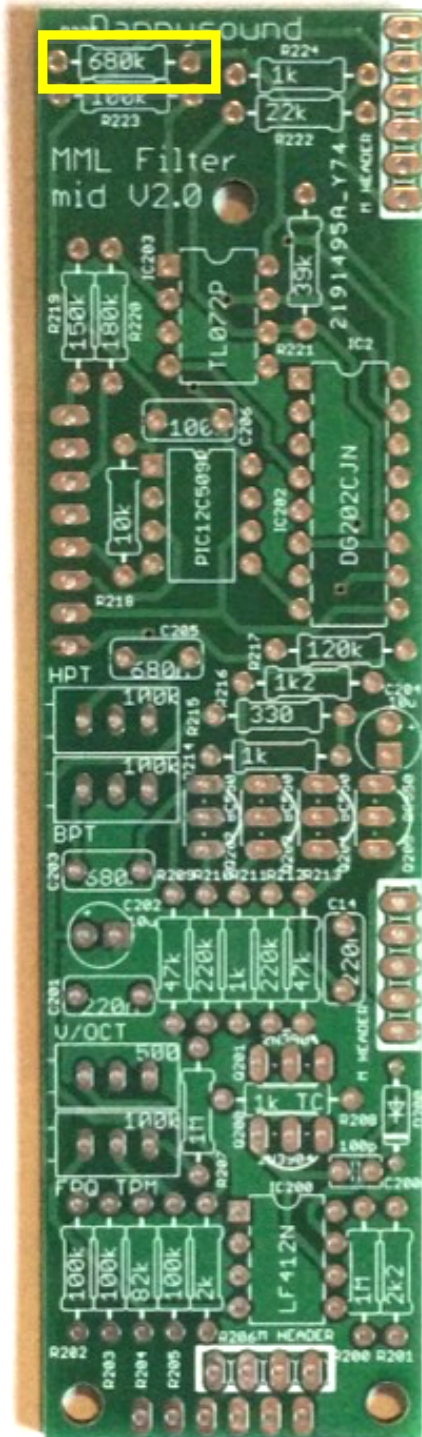

51) – 1 x 680k (R225)

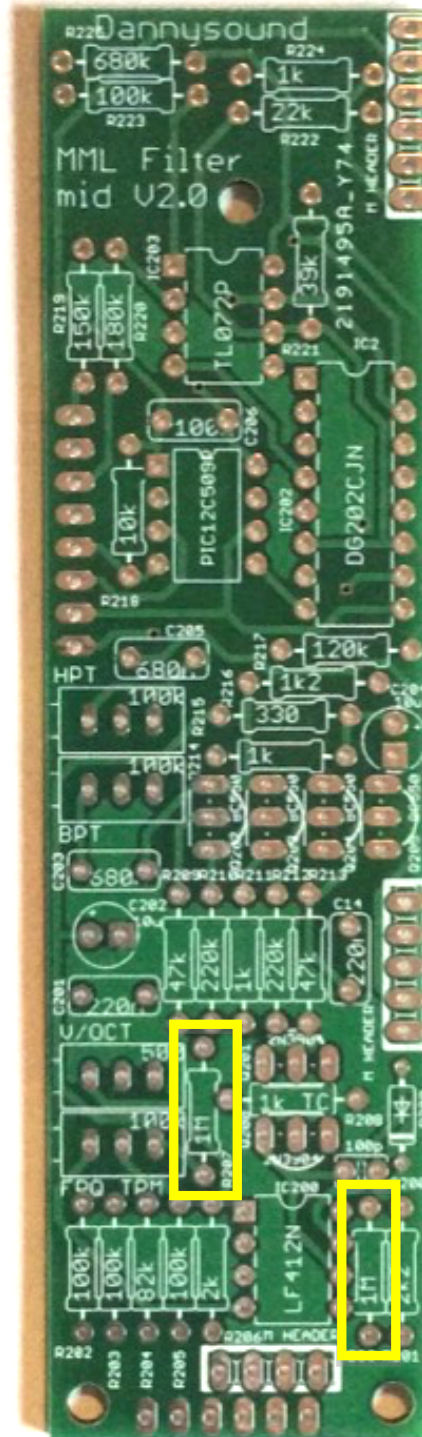

52) – 2 x 1M (R200, R207)

IC SOCKETS

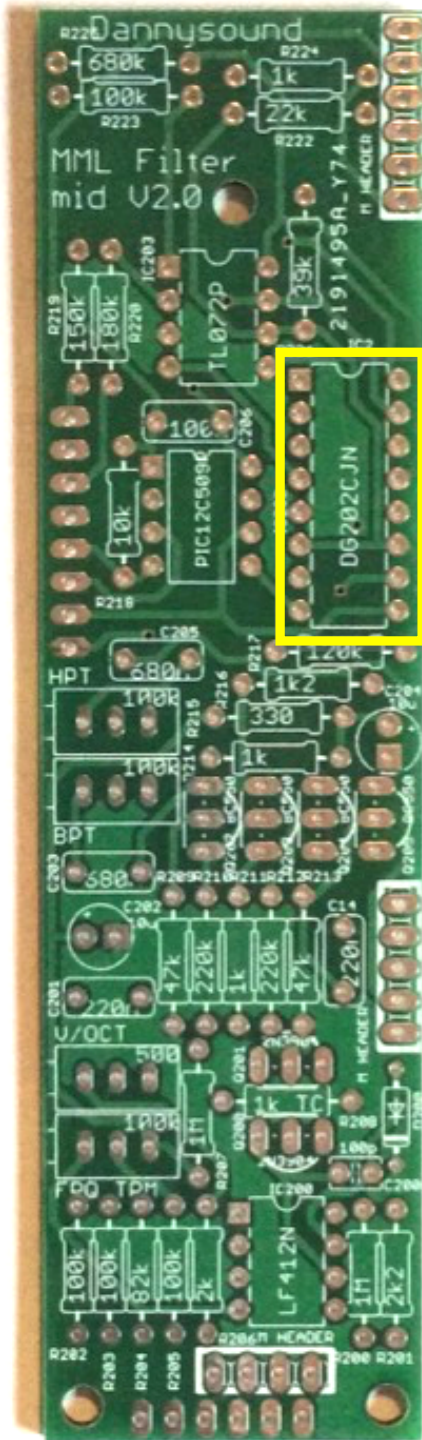

53) – 1 x 16 pin IC socket

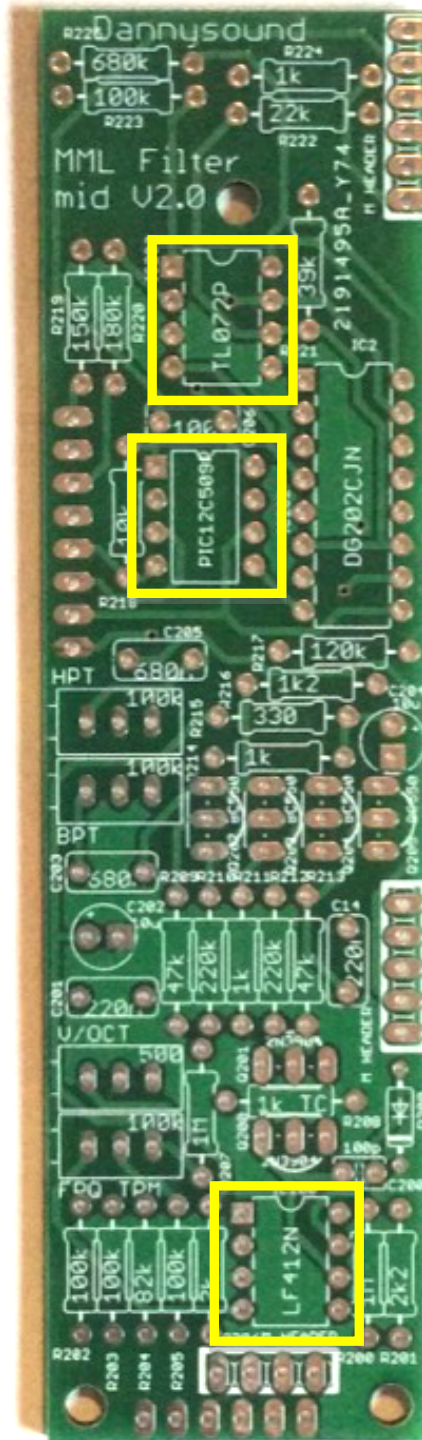

54) – 3 x 8 pin IC sockets

Note: Mind orientation – match the notch on each socket with the notch on the PCB silkscreen.

CAPS



55) – 1 x 100p ceramic (C201)

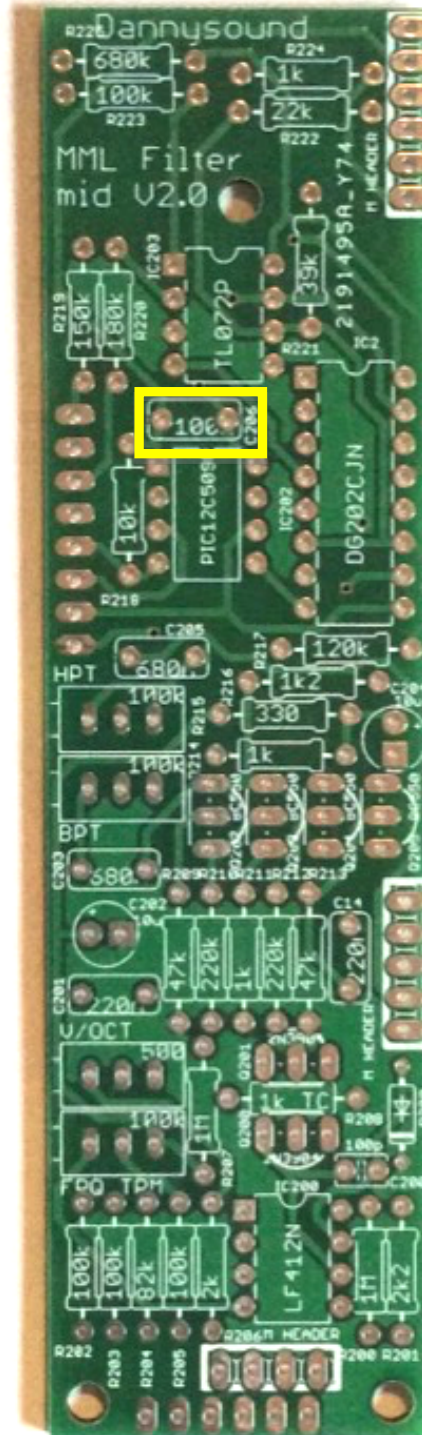

56) – 1 x 100n box (C208)

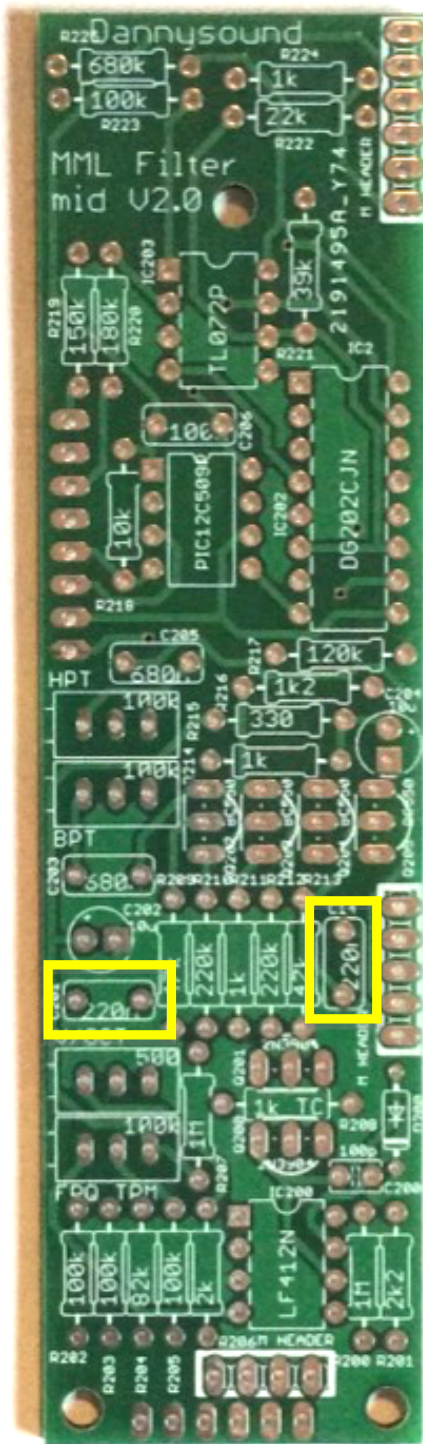

57) – 2 x 220n box (C202, C203)

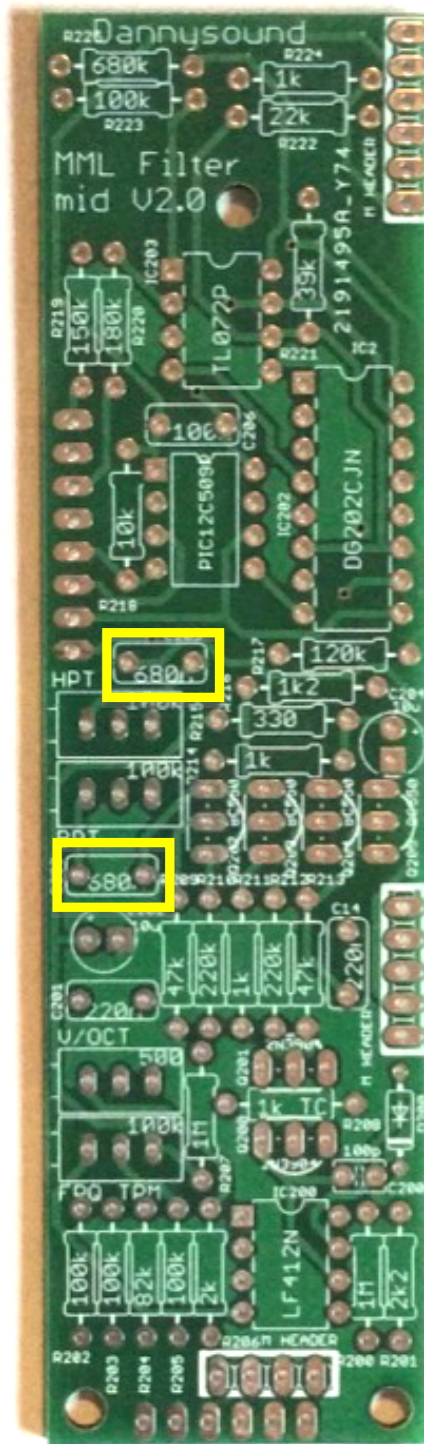

58) – 2 x 680n box (C205, C207)

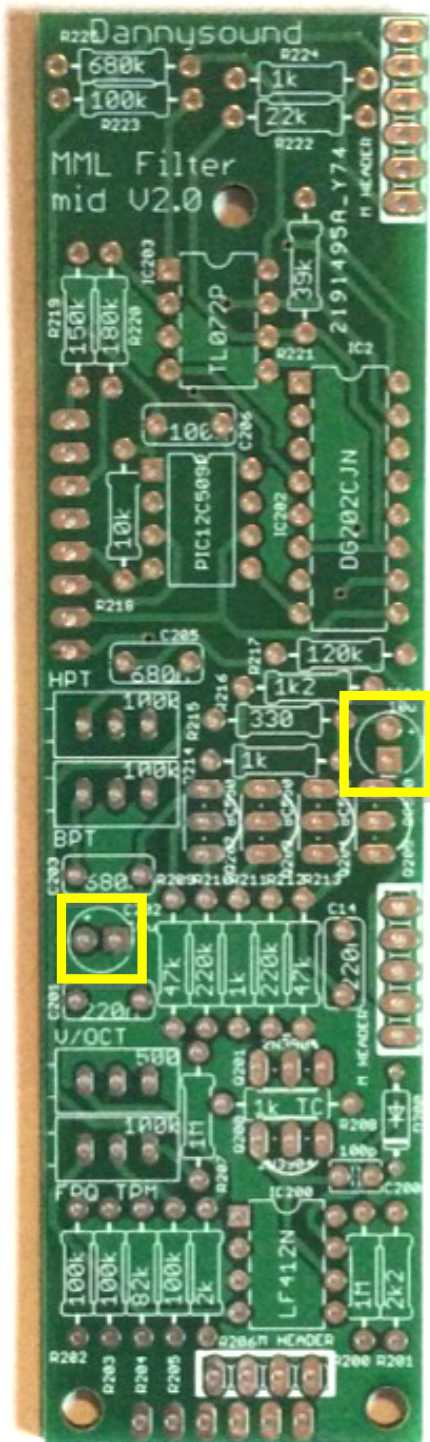

59) – 2 x 10u (C204, C206)

Note: mind polarity - the negative short lead should go to the square pad on the PCB

TRANSISTORS

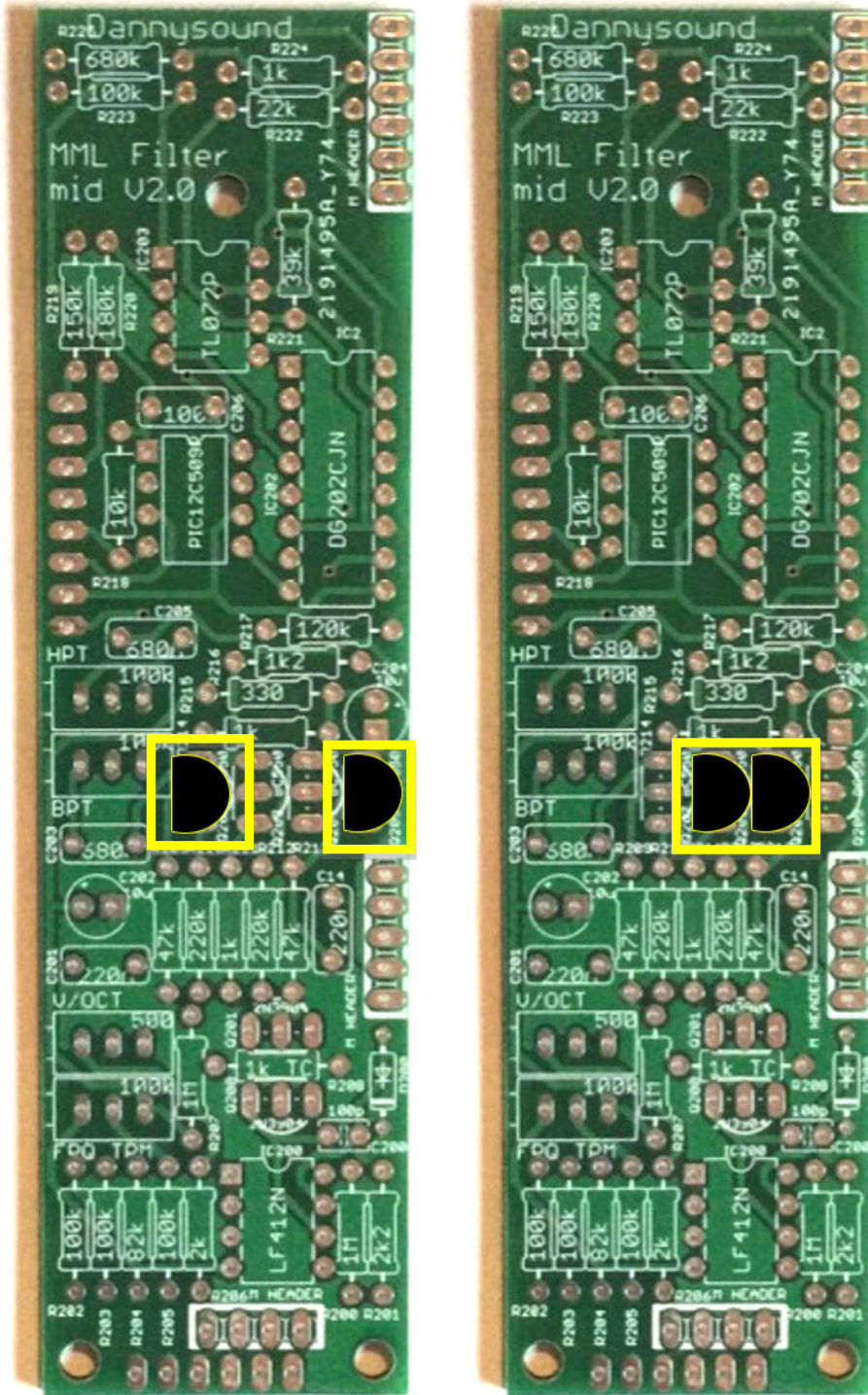

60) – BC550 MATCHED PAIR (Q202, Q205)

61) – BC550 MATCHED PAIR (Q203, Q204)

Note: BC550 matched pairs are located in the bag which contains the PCBs,

Note: mind polarity – match curve of each component with PCB silkscreen)

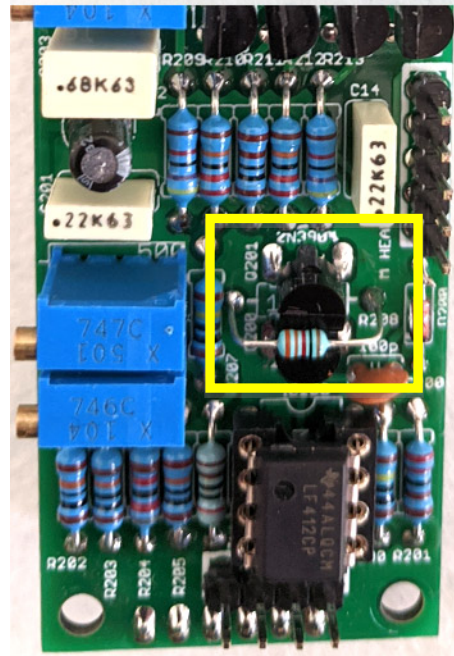
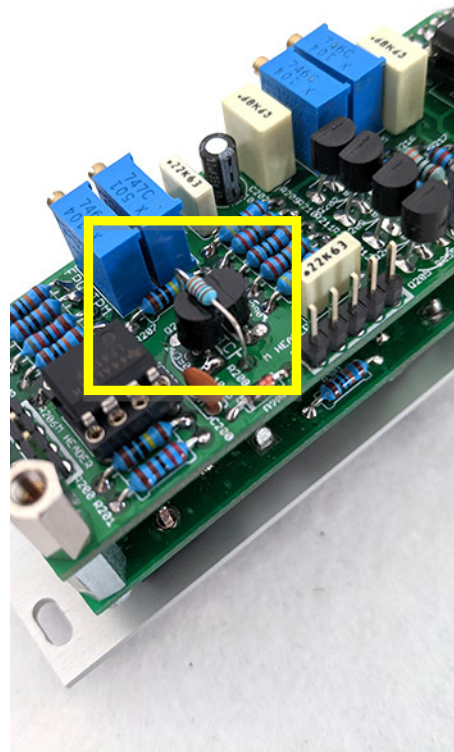
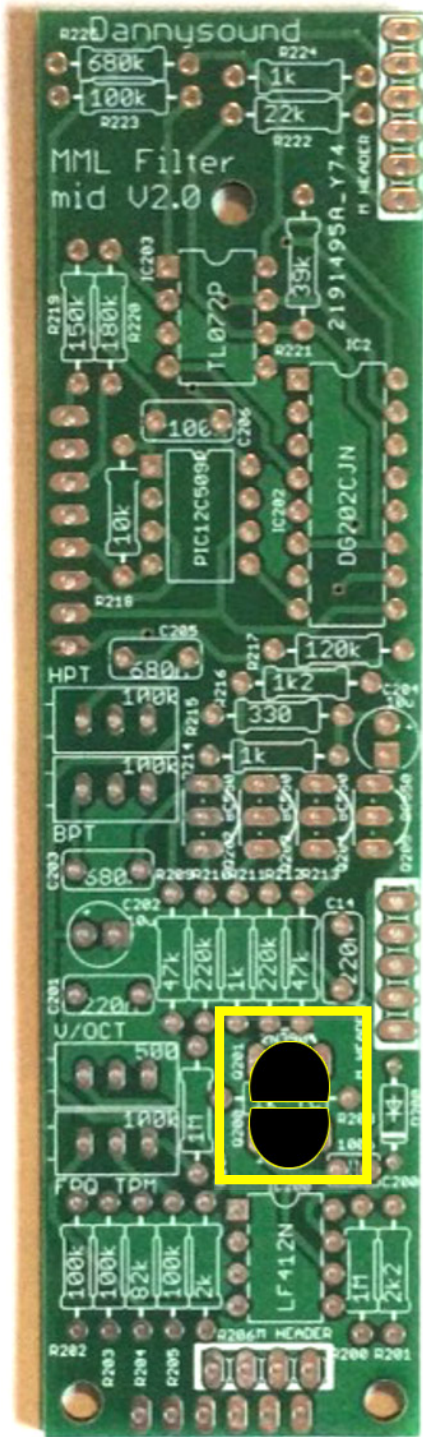

62) – 2N3904 MATCHED PAIR

63) – 1 x 1k Tempco (R208)

Note: mind polarity of matched pair – the flat faces of each transistor should face each other

--Do not confuse with unmatched transistors--

Fit the 1k Tempco – sitting flat on top of the transistors as shown

HEADERS

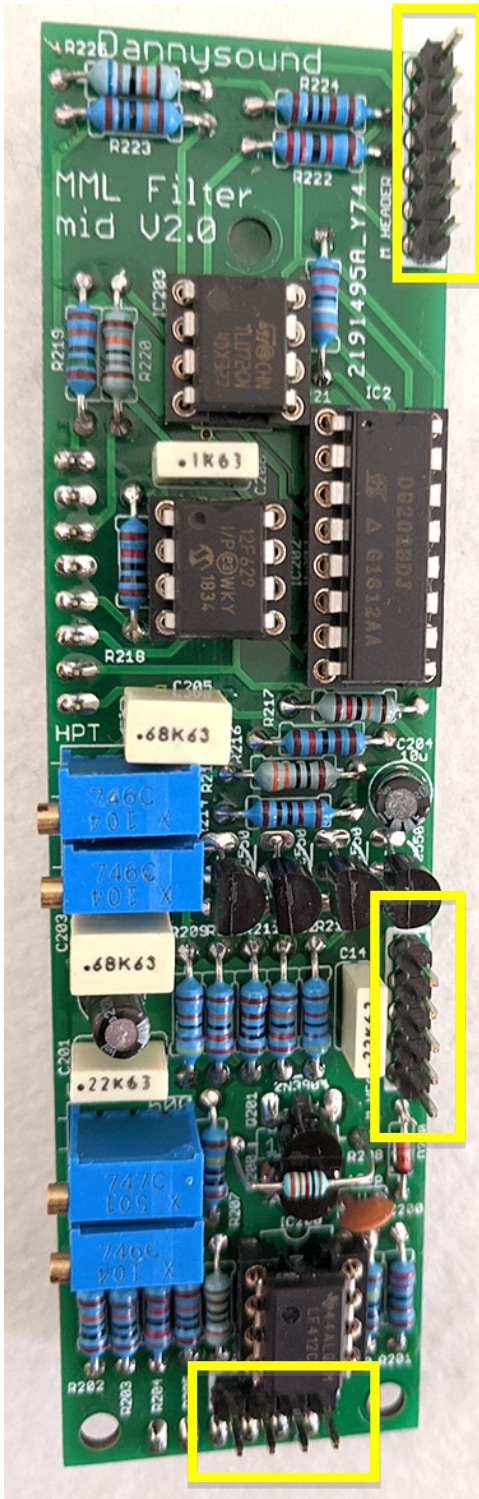

64) – 3 x MALE Headers

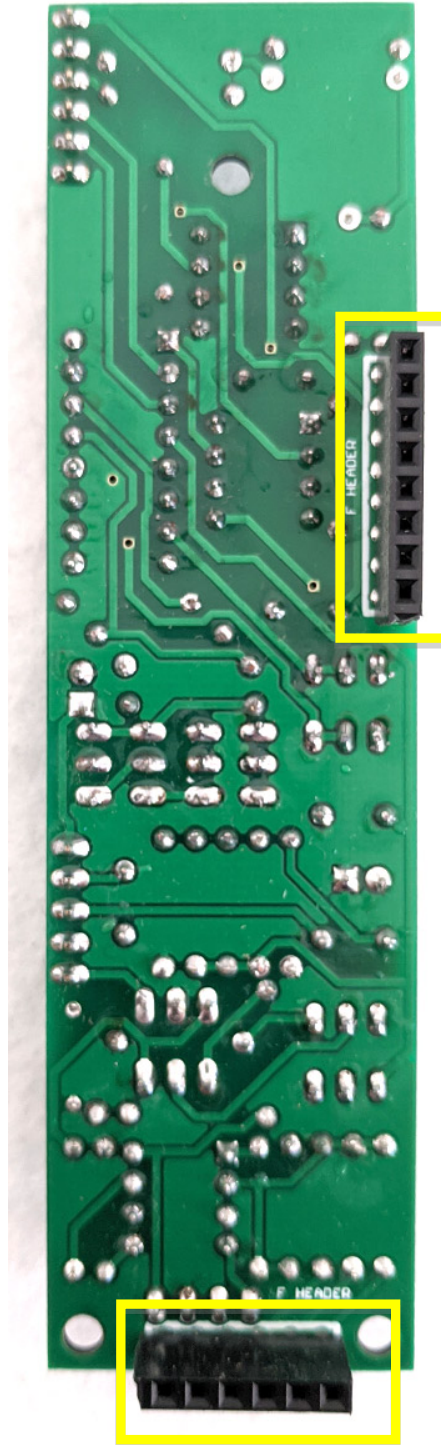

65) – 2 x FEMALE Headers

Note: take care to fit the headers on the correct side of the PCB as shown above

TRIMPOTS

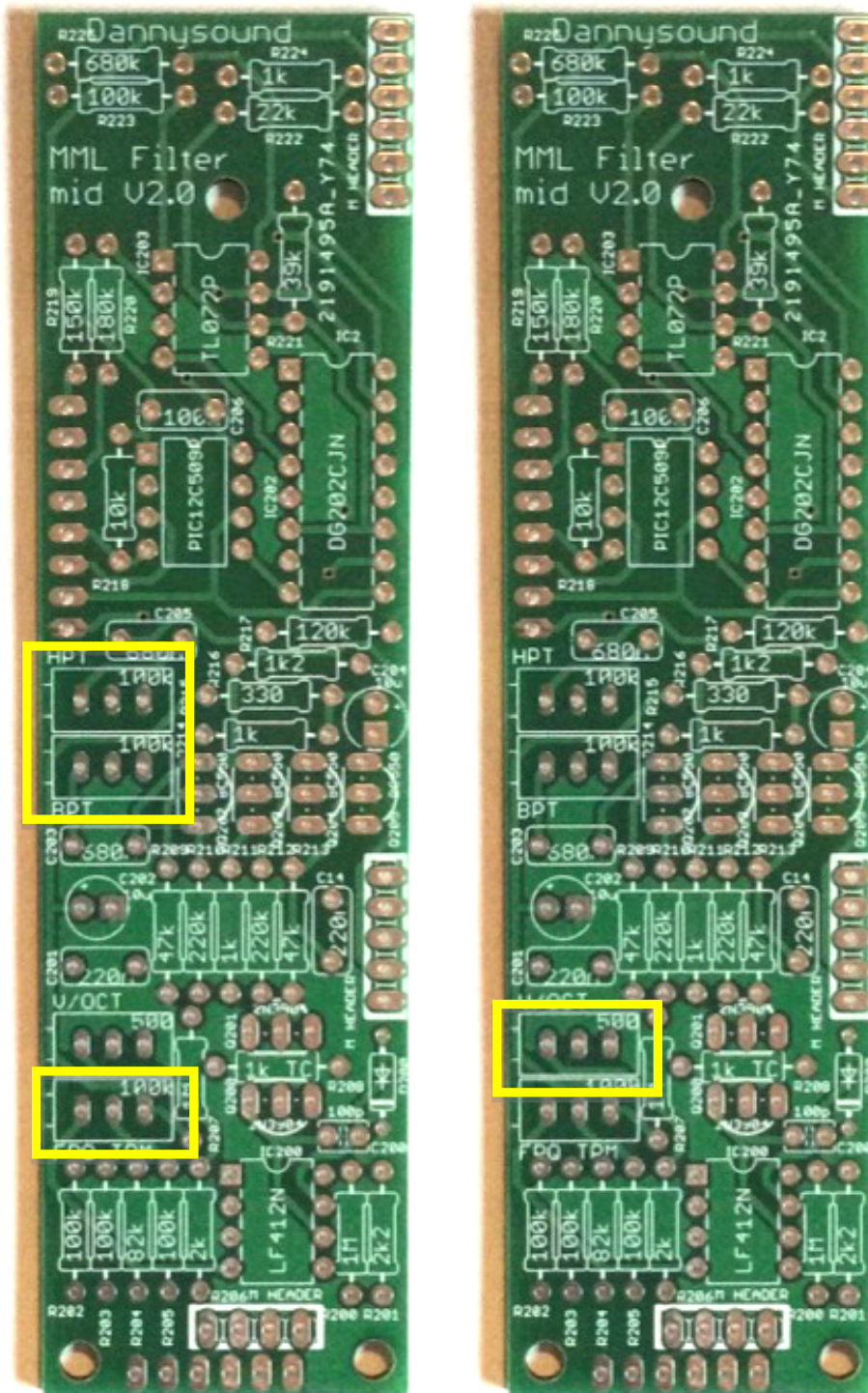

66) – 3 x 100k SIDE ADJUST

67) – 1 x 500r SIDE ADJUST

Note: Mind polarity, the screw should face towards the edge of the PCB ICs

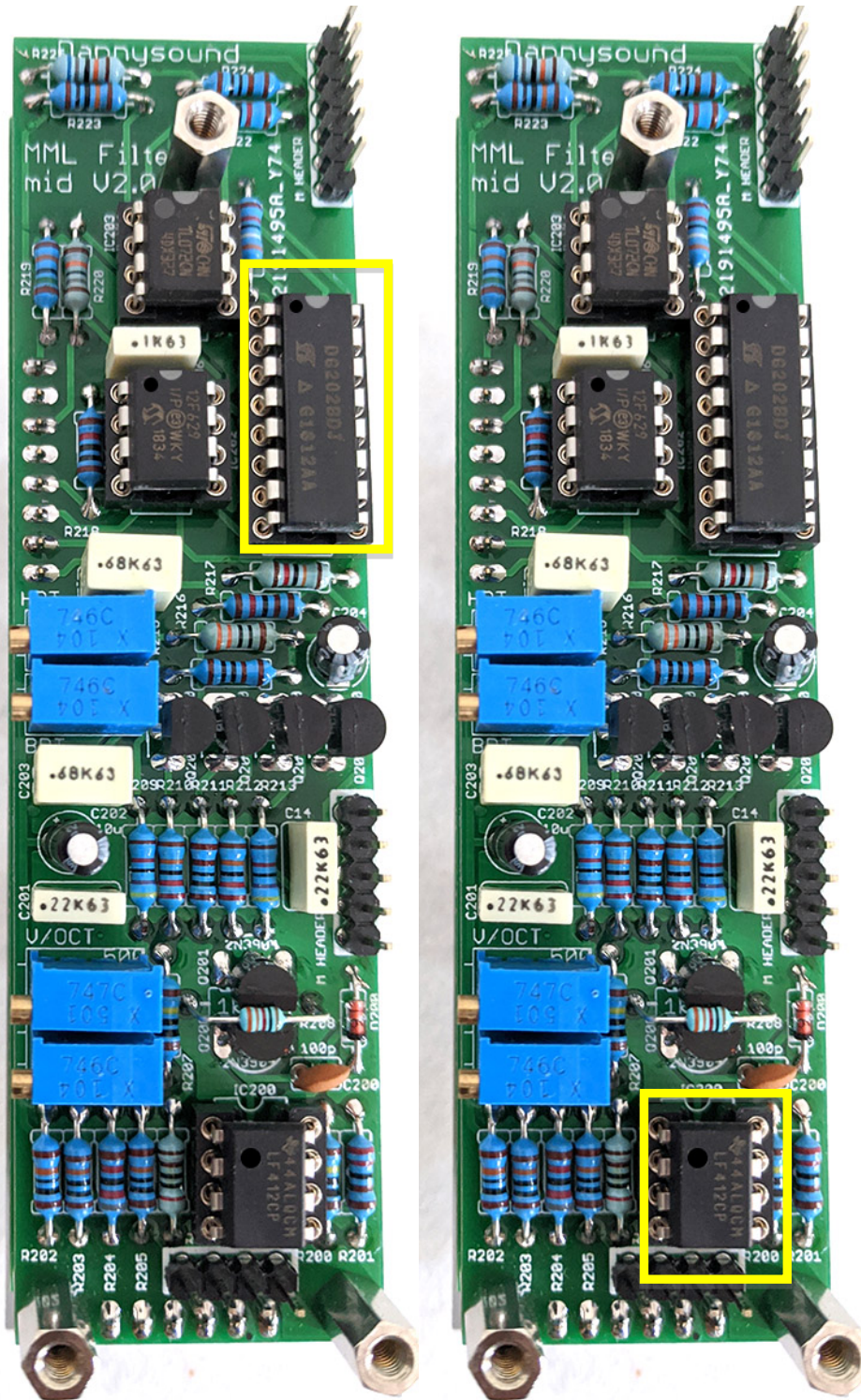

68) – 1 x DG202 (IC201)

69) – 1 x LF412 (IC200)

Note: Mind orientation – match notch or dot on each chip with the notch on PCB silkscreen and IC socket as shown above.

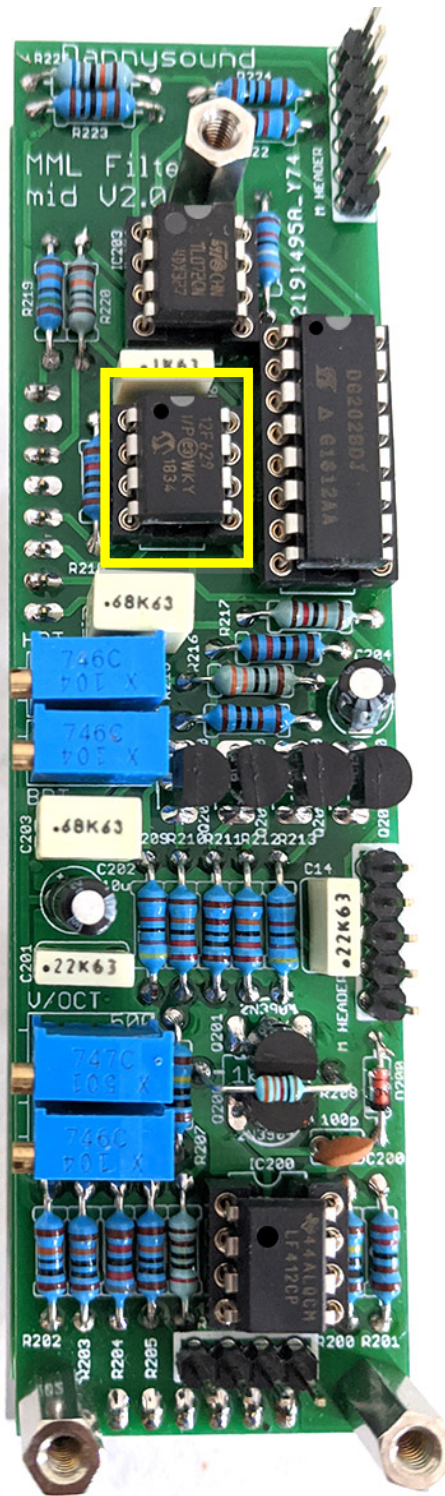

70) – 1 x Pre-programmed PIC (IC202)

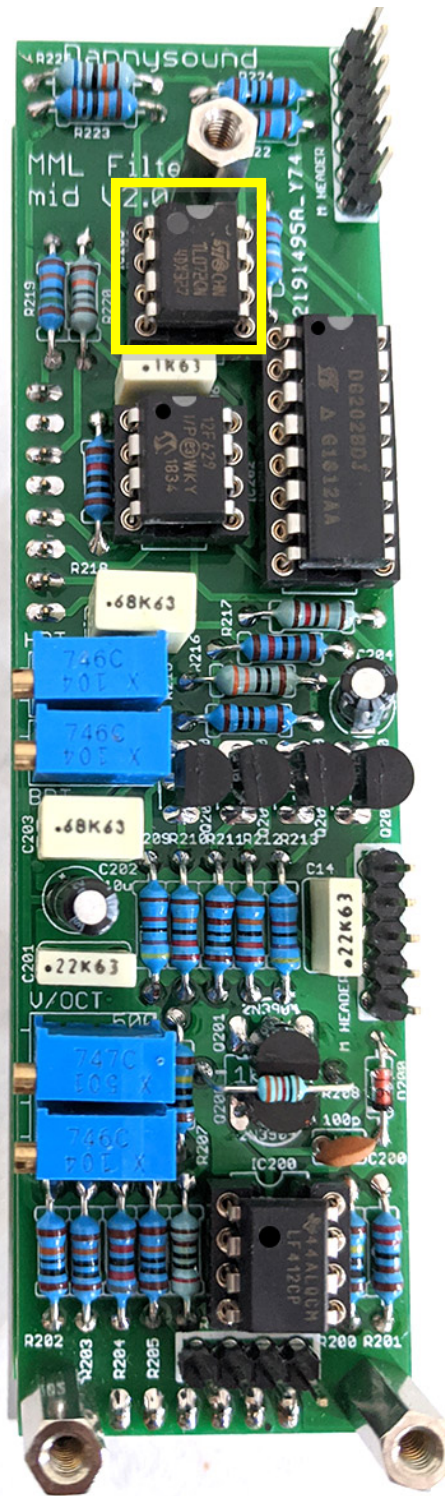

71) – 1 x TL072 (IC203)

Note: Mind orientation – match notch or dot on each chip with the notch on PCB silkscreen and IC socket as shown above.

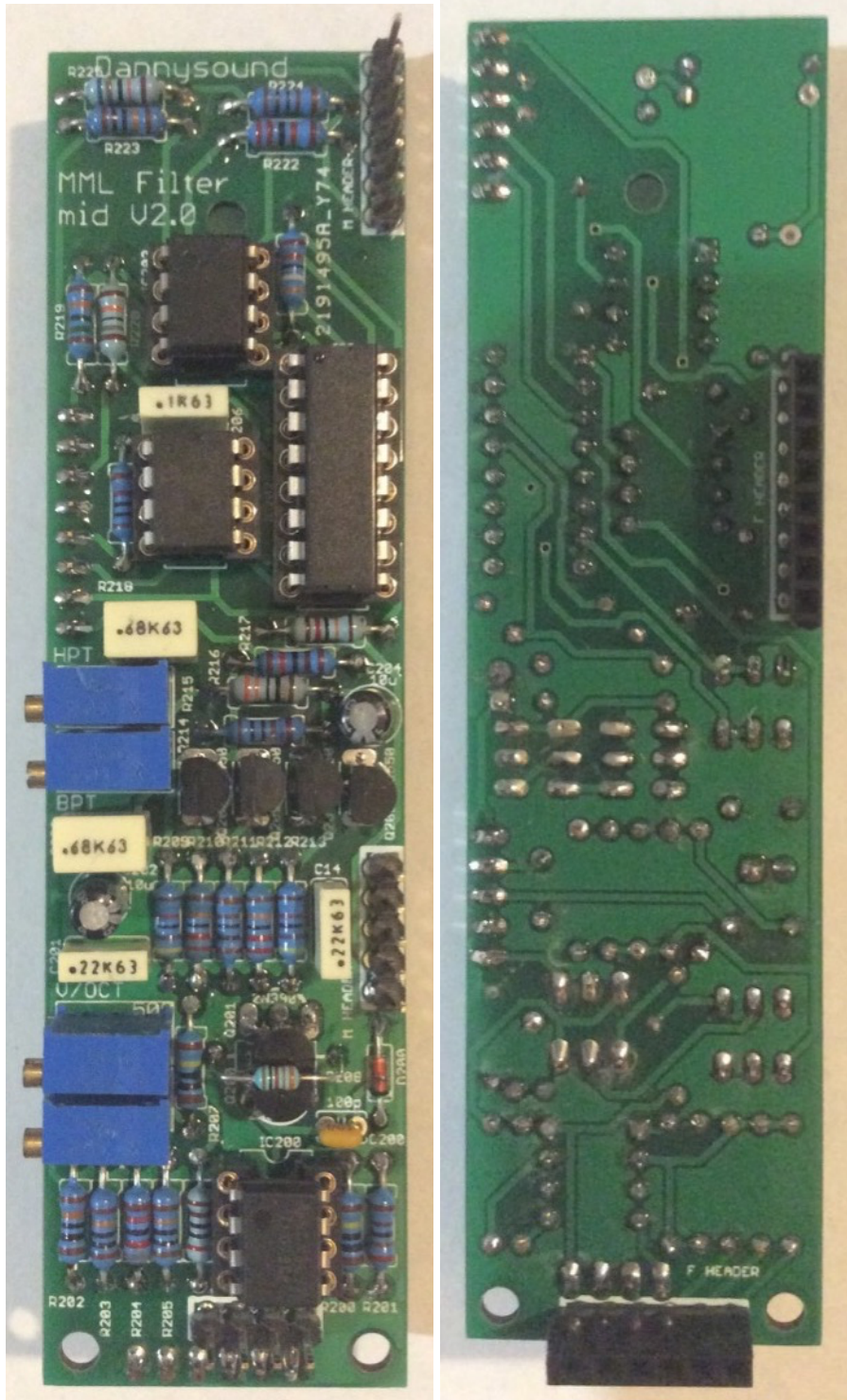

The middle board is now finished

7 Pots Board RESISTORS

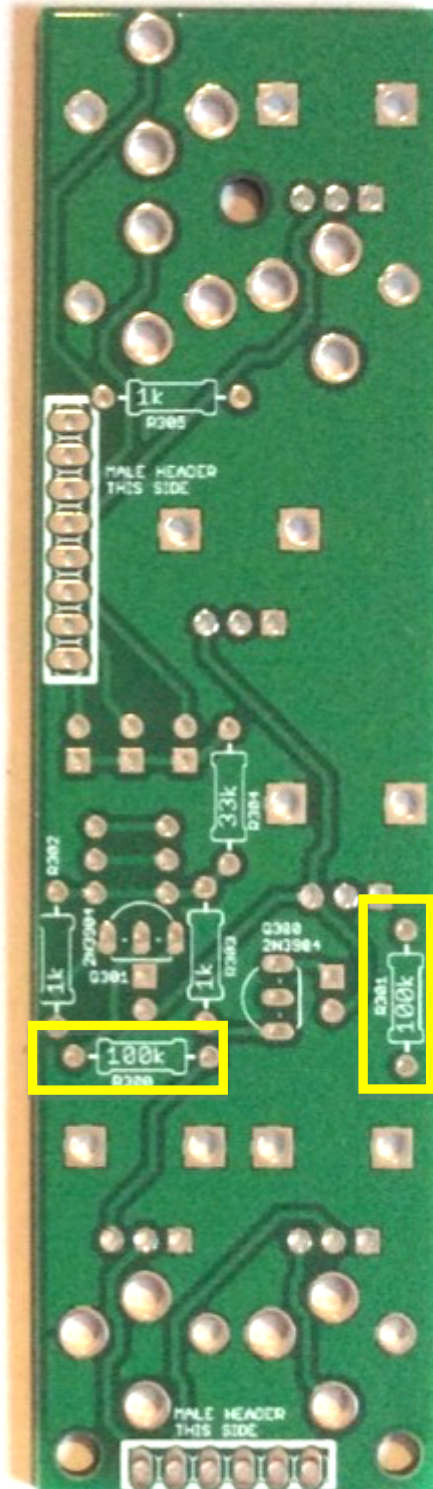

72) – 2 x 100k (R300, R301)

TRANSISTORS AND HEADERS

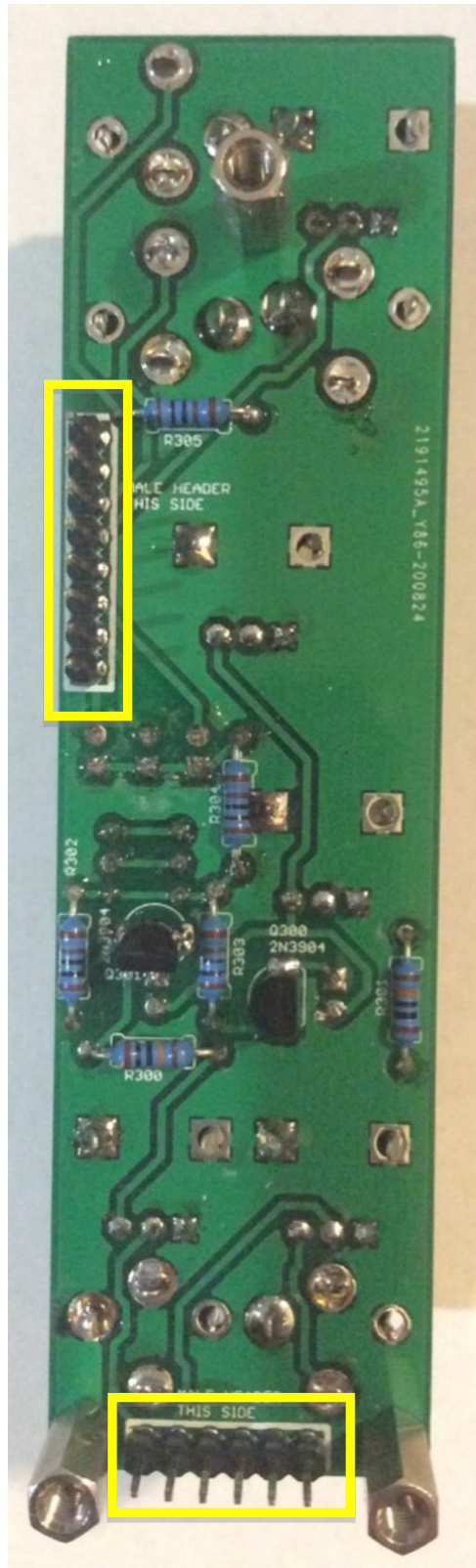
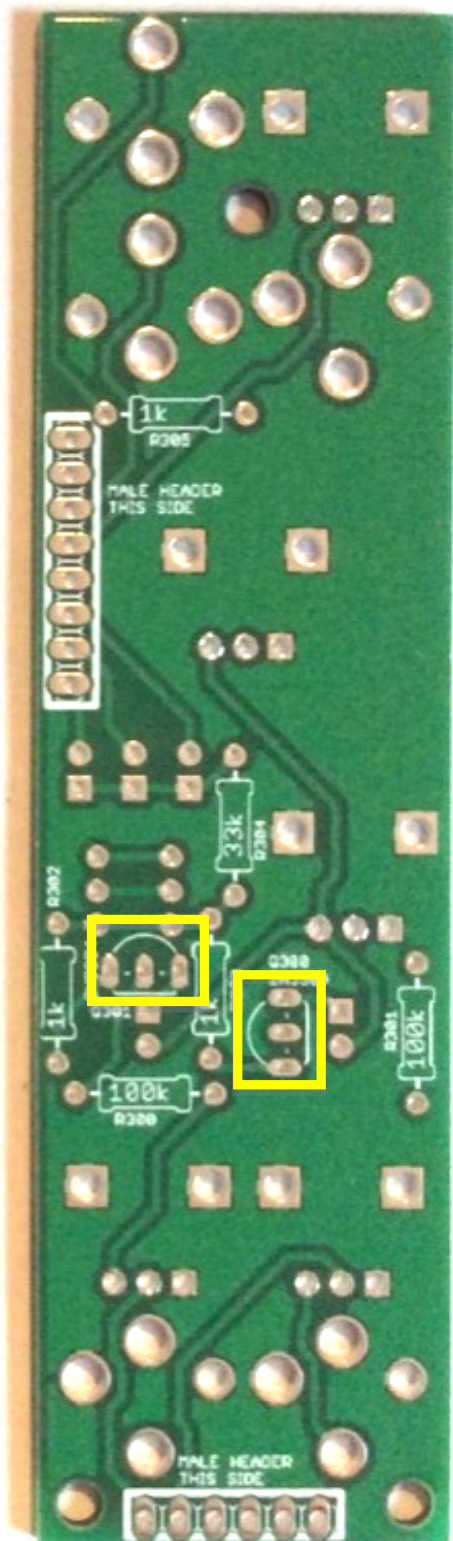

73) – 2 x 2N3904 (NOT MATCHED) 74) – 2 x MALE Headers
(Q300, Q301)

Note: Match the curve of transistors with PCB silkscreen

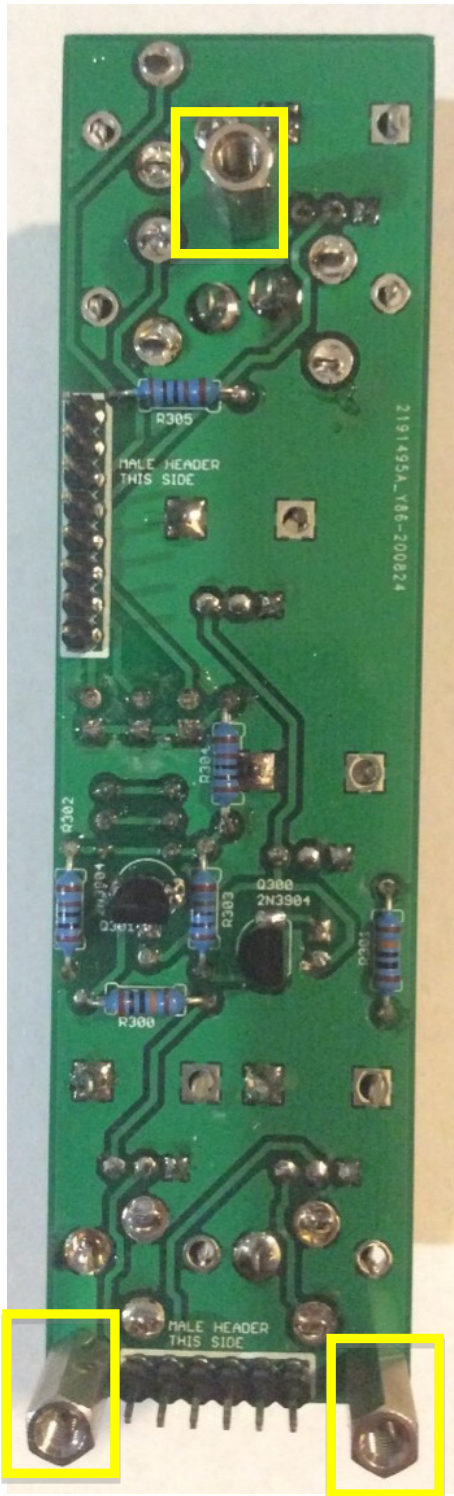

Now is a good time to screw on the female-female 11mm hex standoffs

8 Panel Components and Final Assembly

These Components should be inserted but **NOT SOLDERED** until the panel has been placed on top of the PCB. This is to ensure that the PCB fits the panel properly.

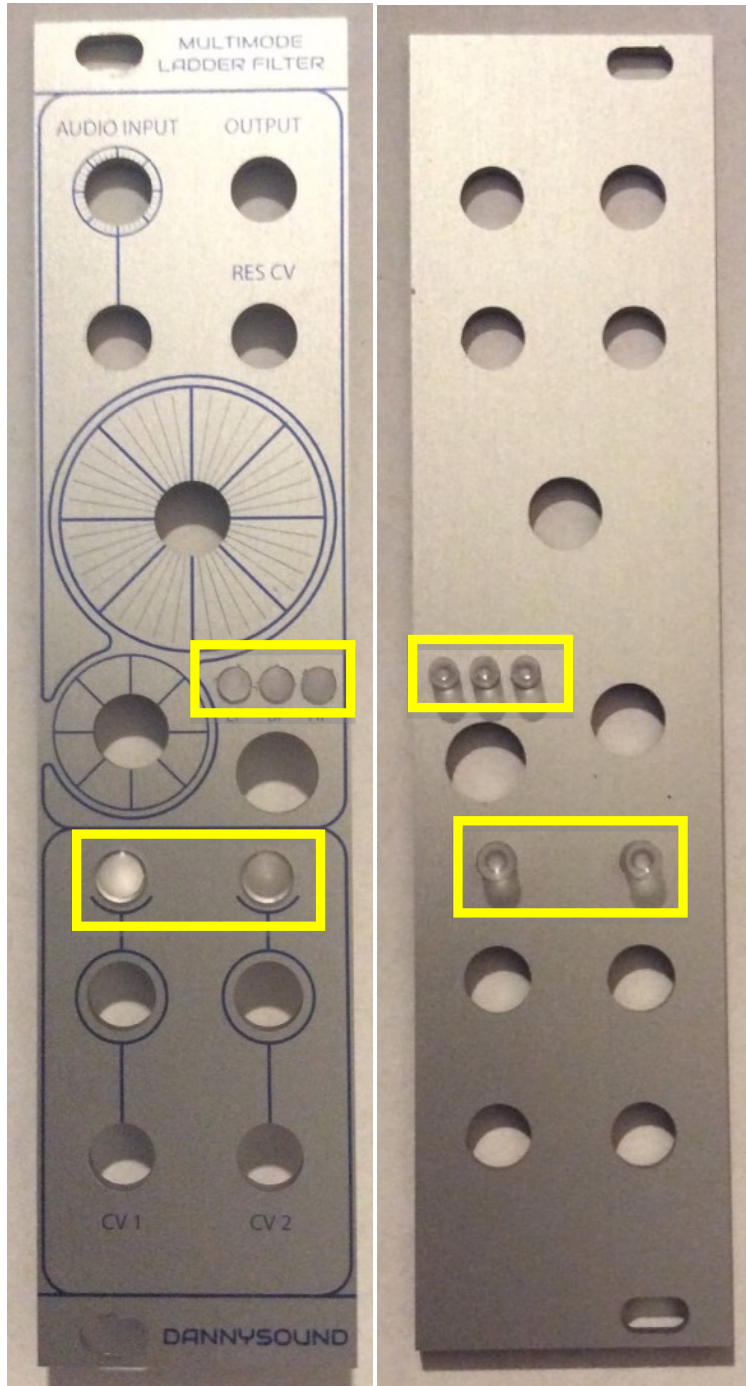

75) – **2** x 5mm light pipes, and **3** x 3mm light pipes

Use the rubber holders to keep the 5mm light pipes secure

POTS

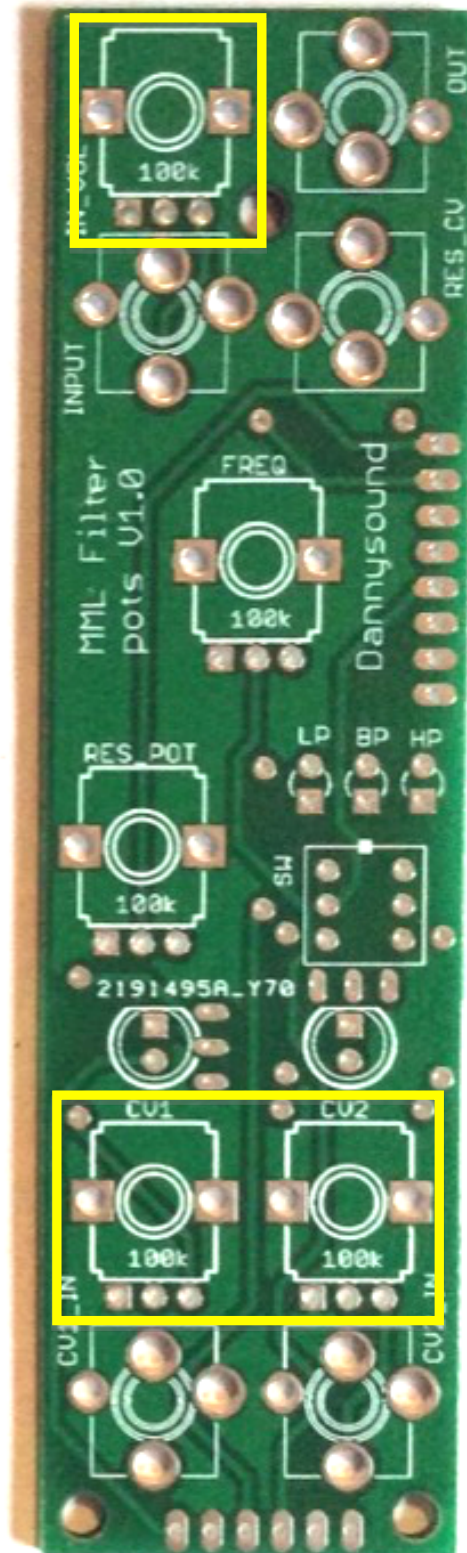
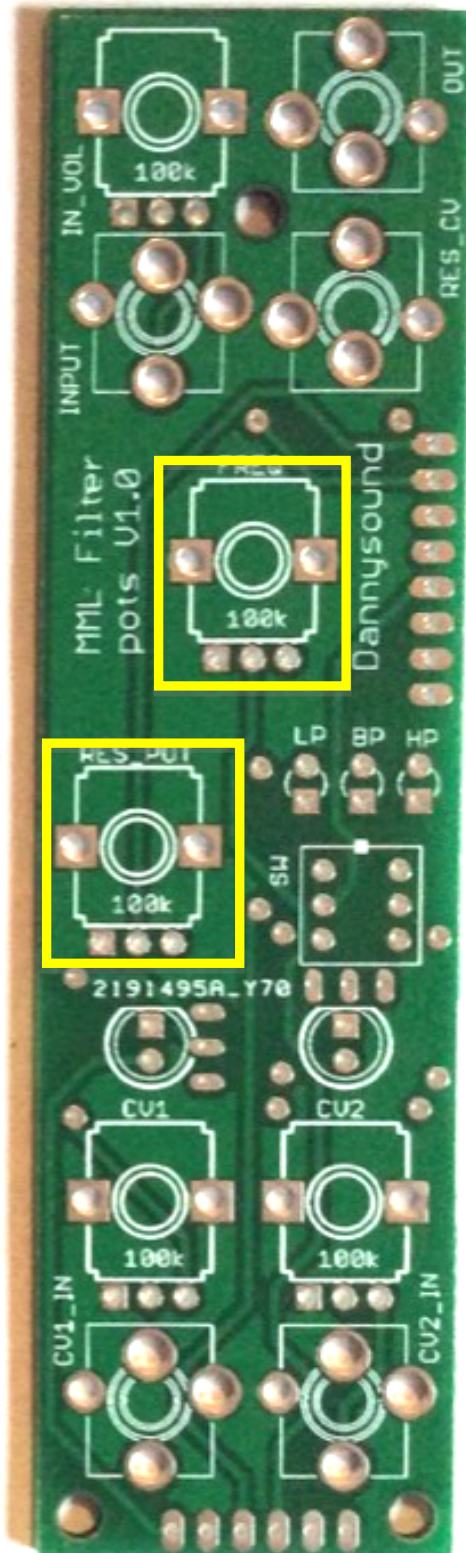

76) – 2 x Alpha B100k (linear) pots
(metal, green)

77) – 3 x TALL TRIMMERS B100k
(plastic, blue & black)

Remember: Don't solder anything yet

SWITCH

(TIP - ONLY SOLDER ONE PIN OF THE SWITCH UNTIL PANEL IS FITTED TO ENABLE EASY REPOSITIONING IF REQUIRED)

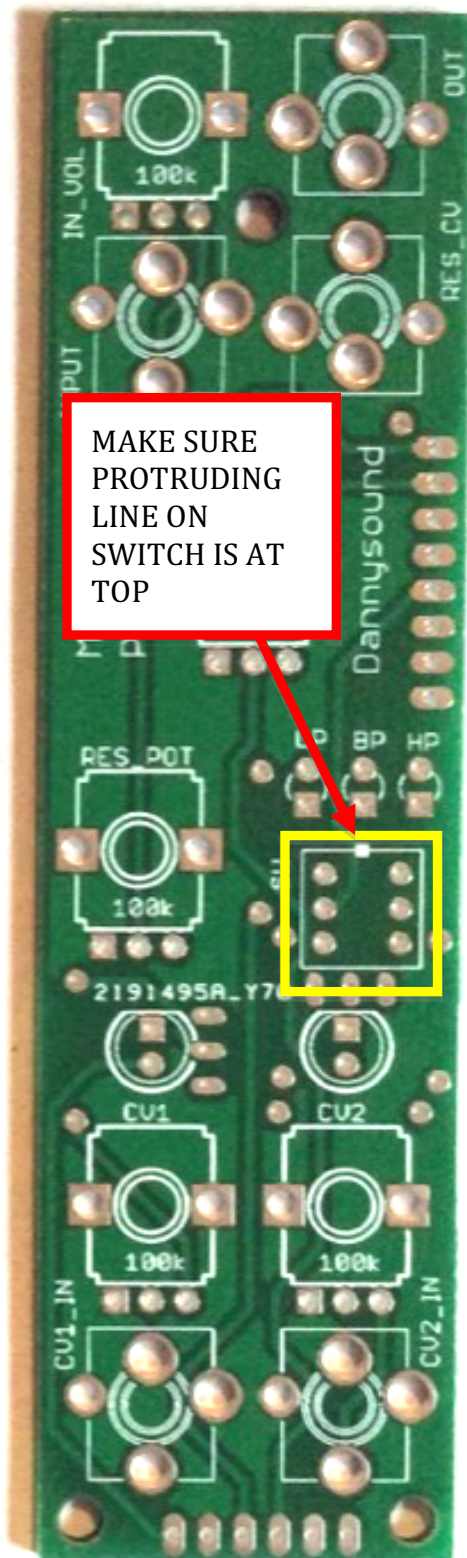

MATCH LINE ON SWITCH WITH DOT ON PCB SILKSCREEN

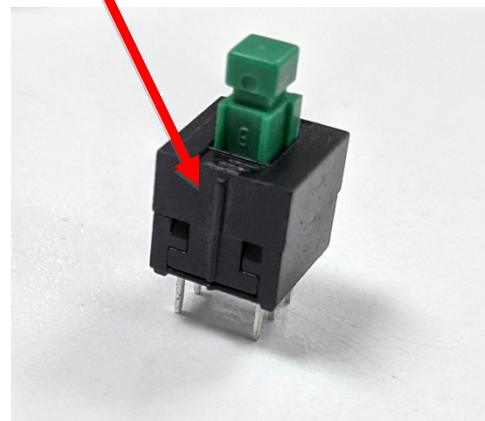

78) – 1 x PUSH SWITCH – NOTE: ORIENTATION IS VITAL!

JACK SOCKETS

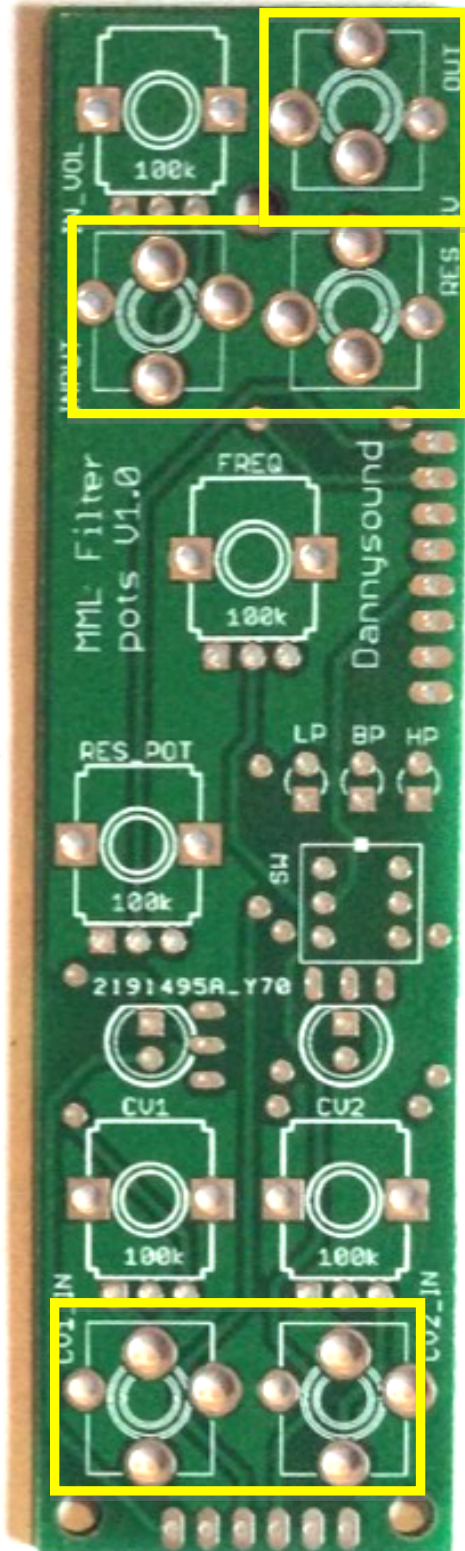

79) – 5 x PJ301BM Jack Sockets

Remember: Don't solder anything yet

LEDs

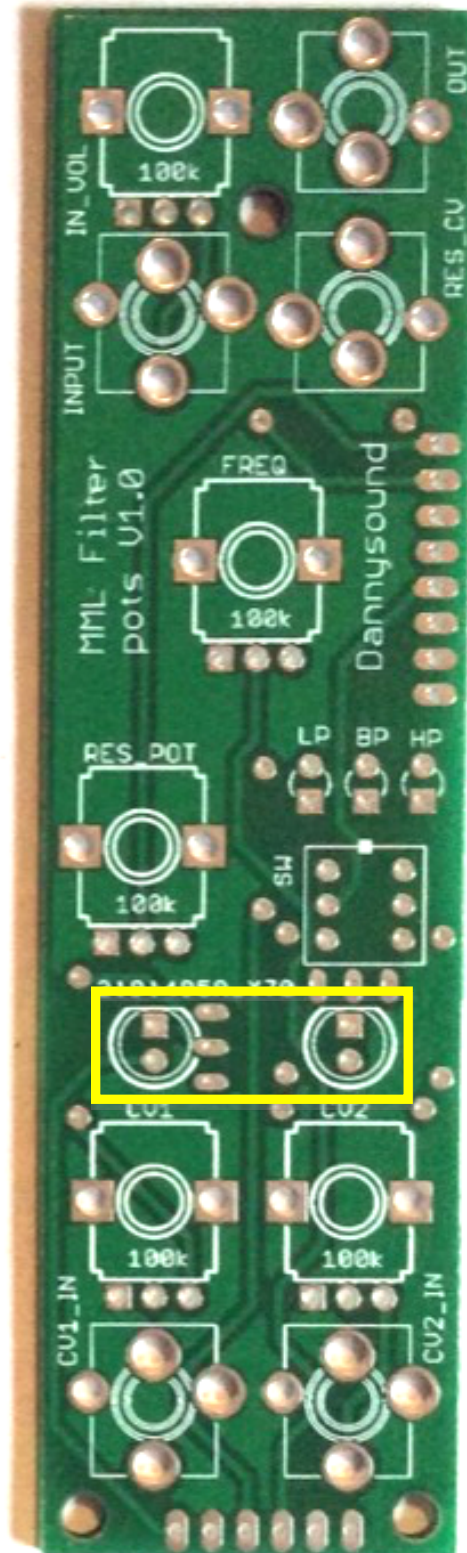
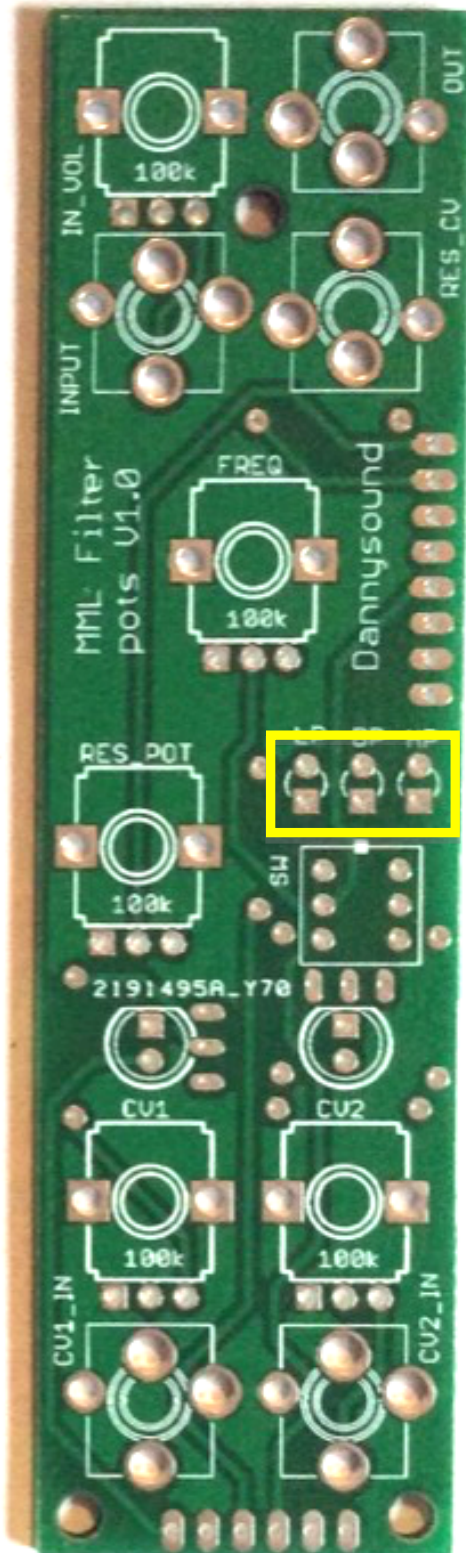

80)– 3 x AMBER LEDs

81) – 2 x RED LEDs

NOTE: orientation is vital for all LEDs, the shorter leg should go to the square pad

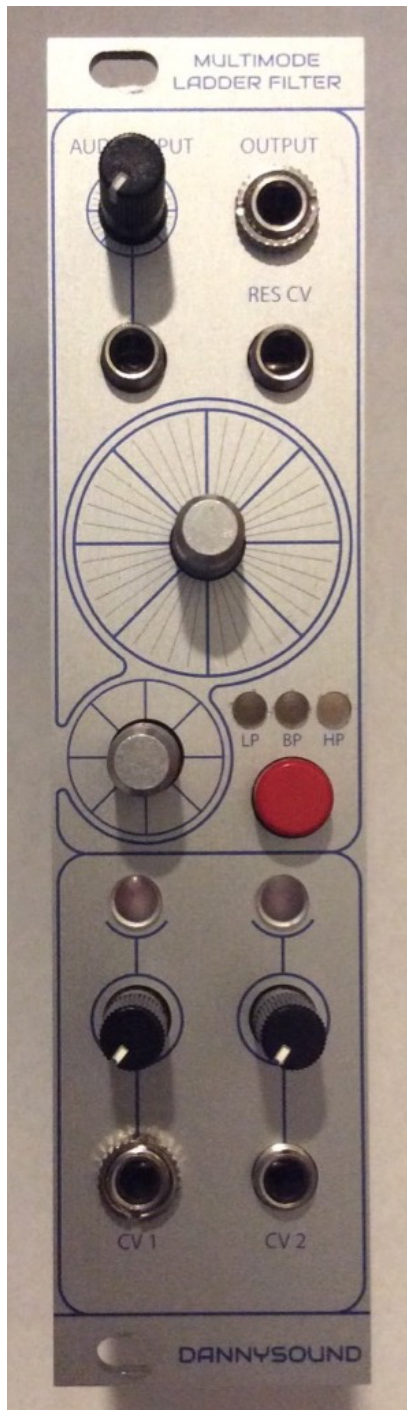

82) – Fit the panel in place then while holding everything together turn over and solder one pin of the lower CV 1 jack socket and one pin of the output jack socket. Ensure these sockets are pressed to the PCB properly (reflow the solder whilst applying pressure to the socket if its not a snug fit) then attach the 2 nuts as shown above to keep everything in place.

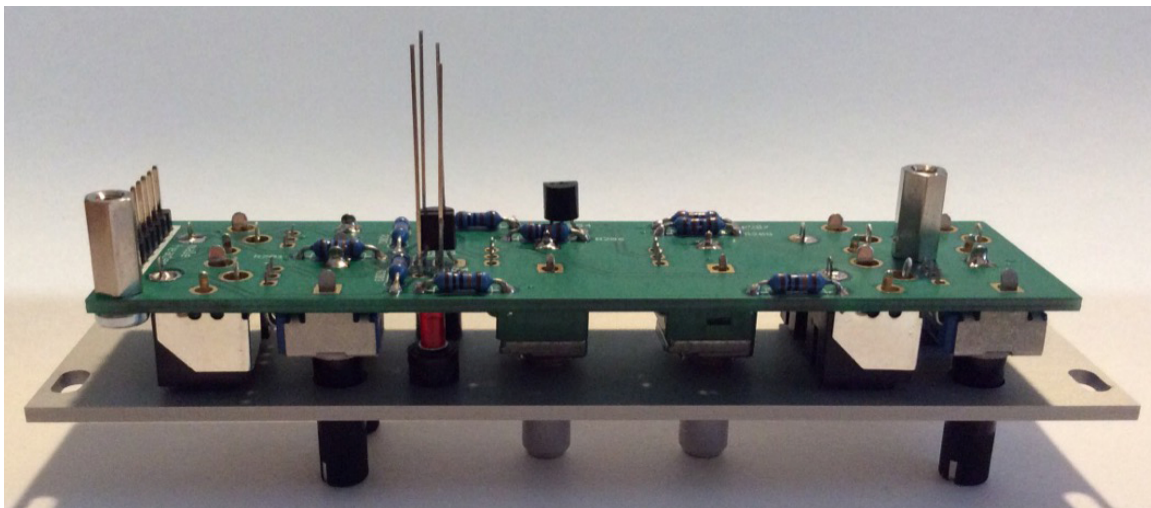
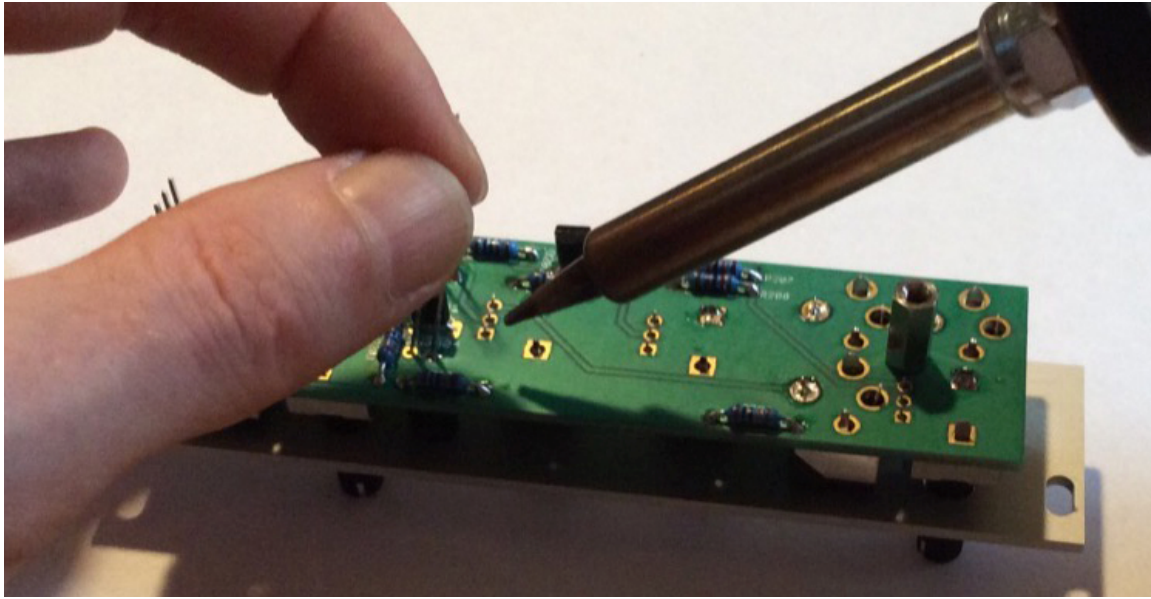

TIP – Solder only one leg of the LEDs, you can then reflow the solder to that pin while holding the LED legs to position it against the light pipe when the pots PCB is attached to the panel. (Picture is for illustration purposes only and not the MML Filter module!)



83) – Add the knobs then solder one of the ground tabs of each pot (including the tall trimmers). There is a little room for adjustment of the tall trimmers and pots so if they look out of alignment against the graphics or if the tall trimmers slightly rub when turn them you can reflow the solder whilst applying a little pressure to get them positioned perfectly.

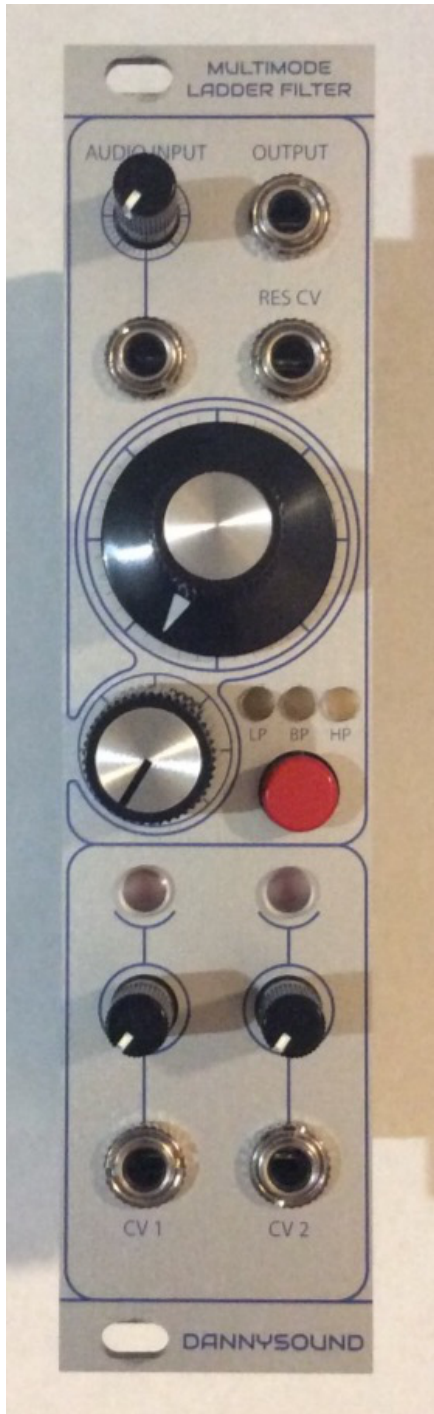

84) – Add the rest of the nuts to jack sockets to hold everything together firmly. Once that's all done and looking good you can solder the rest of the pins of each component.

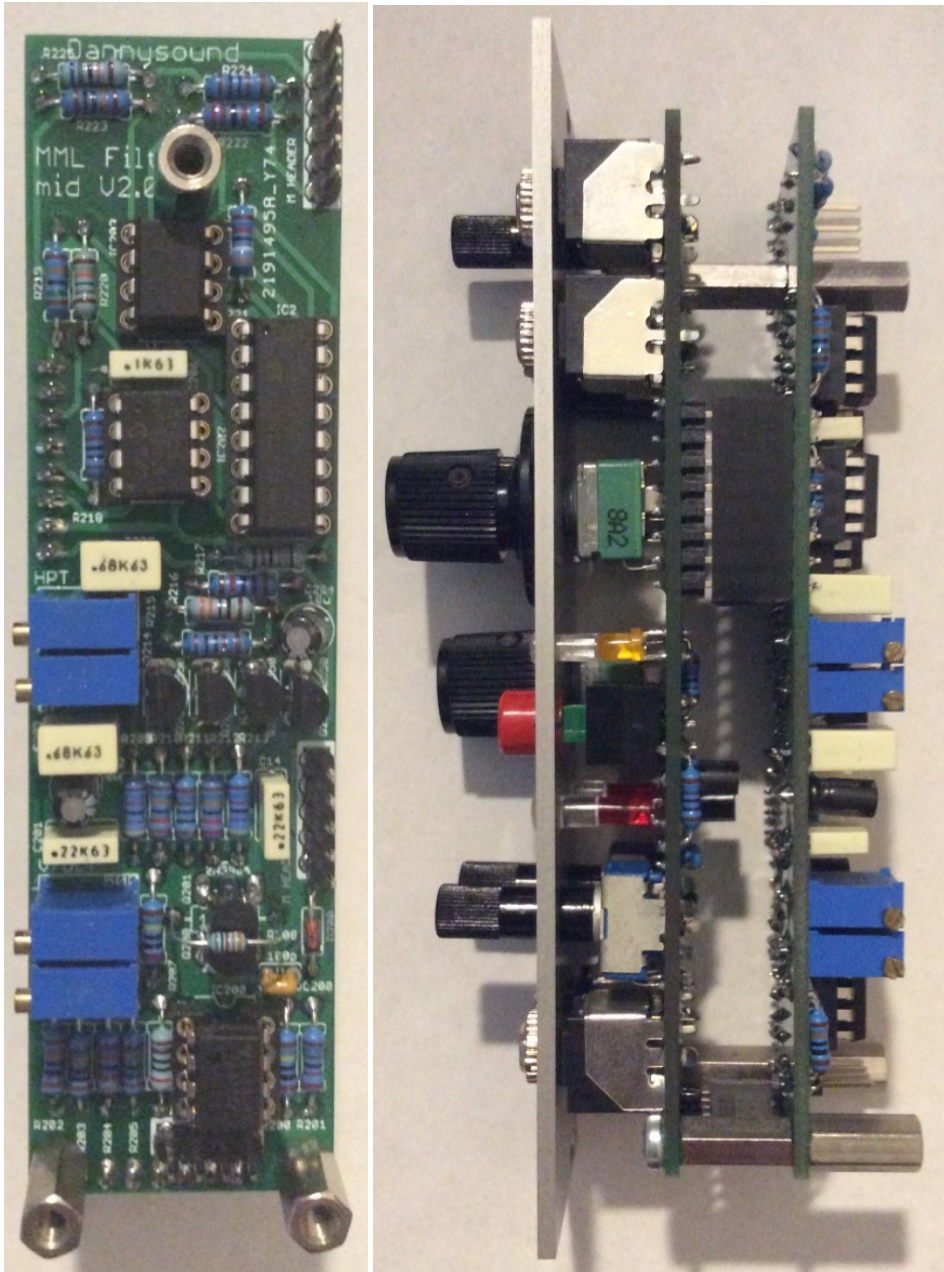

85) – Attach the mid board and 3 x Male to Female 12mm standoffs.

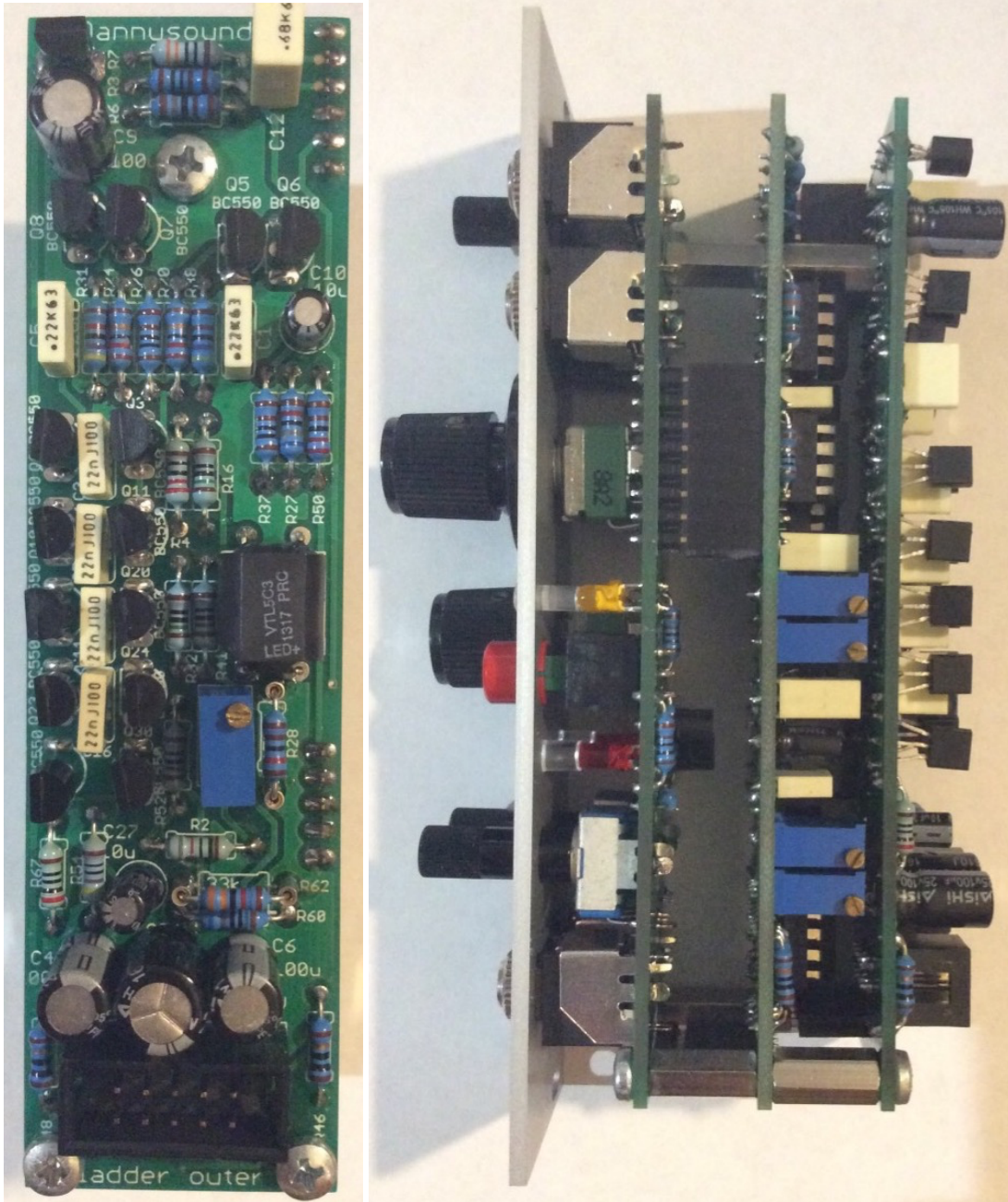

86) – Attach the outer board and screws

Trimmer Identification

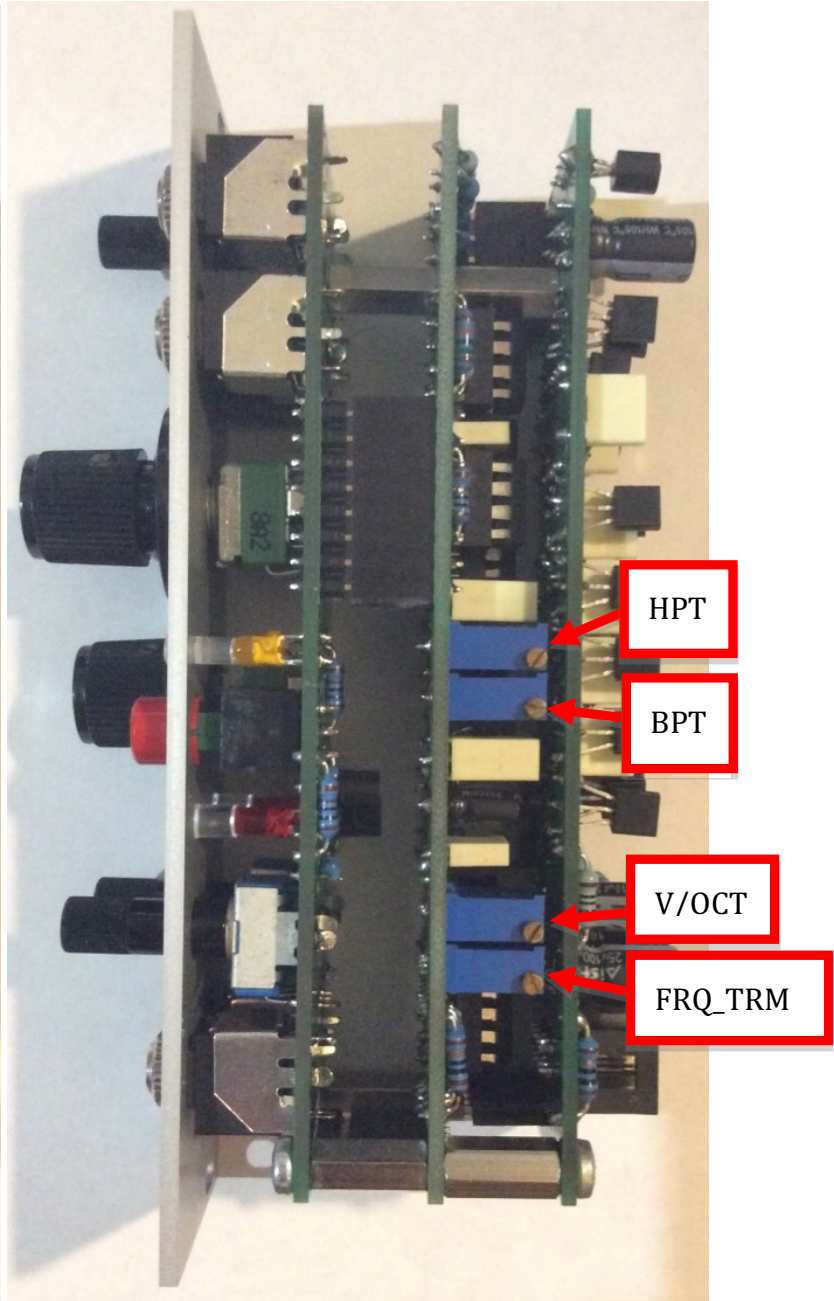
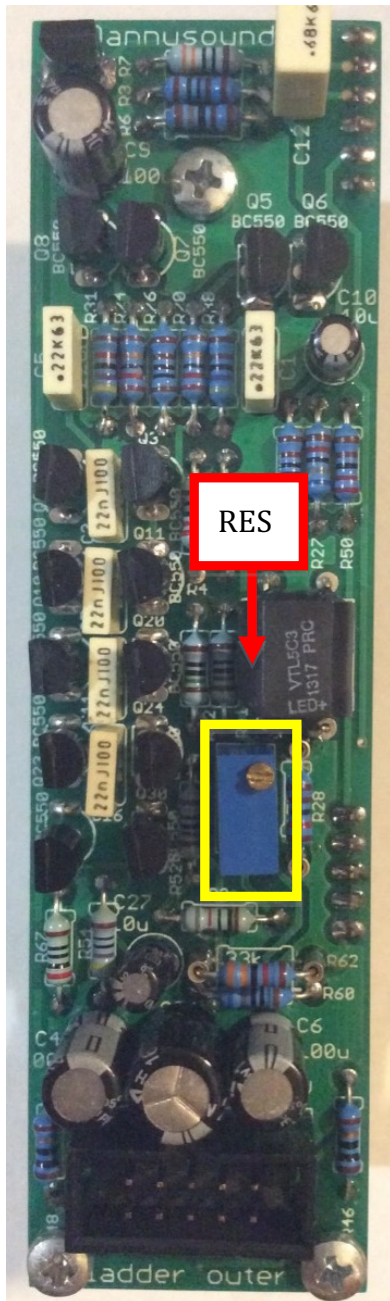

9 Testing and Calibration

The calibration procedure can be done by ear and requires no special equipment apart from a tuner or reference note of A 440Hz. The trimpot references have been highlighted in red to distinguish them from the panel controls.

Resonance calibration and initial test.

1. Connect the OUTPUT of the filter to an amplifier.
2. Connect an oscillator square or saw wave to the MML Filter INPUT.
3. Ensure LP filter is selected (LED should be lit).
4. Set INPUT VOLUME to 60% (From around 70% or higher the input will start to be overdriven with a $\pm 5V$ input signal).
5. Rotate FREQUENCY control to ensure filter is working as expected (no output at 0, full signal at 100%).
6. Set INPUT VOLUME to 0.
7. Turn up RESONANCE to 100% and set FREQUENCY to around 440Hz (note A on a keyboard etc).
8. Set RESONANCE to around 55%.
9. Adjust **RES trimpot** so the resonance is just at the point of self oscillation.

V/Oct calibration

1. Connect output to amplifier.
2. Connect V/Oct source to CV 1 input and turn the CV 1 input volume up full.
3. Ensure LP filter is selected (LED should be lit).
4. Turn RESONANCE up full.
5. Play a low A (440Hz) at the keyboard and tune the FREQUENCY control to produce a 440Hz tone.
6. Play an A note 2 octaves up (1760Hz) on the keyboard and compare with A at 440Hz.
7. Adjust the **V/OCT trimpot** until there is 2 octaves difference between the 2 notes.

Frequency Calibration

1. Connect OUTPUT to amplifier.
2. Ensure LP filter is selected (LED should be lit).
3. Set RESONANCE up full and FREQUENCY to 50%
4. Ensure all other control are set to 0.
5. Adjust **FRQ_TRM trimpot** to produce A 440Hz.

Band Pass and High Pass Filter Calibration

1. Connect OUTPUT to amplifier.
2. Connect Square or Saw wave output of an oscillator to the INPUT.
3. Set oscillator pitch to produce a bass type frequency.
4. Set INPUT volume to around 60%.
5. Set RESONANCE to around 30% – 40% and FREQUENCY up full.
6. Select BP filter.
7. Adjust **BPT trimpot** so the least amount of signal is audible.
8. Select HP filter.
9. Adjust **HPT trimpot** so the least amount of signal is audible.

10 Modifications

Bass compensated vs classic style transistor ladder filter.

The MML Filter features bass compensation so that the bass doesn't drop out as much when the resonance is increased.

The bass compensation can be removed to get a more classic style resonance response by removing R115 (2k2).

This change will require recalibration of the RES, HPT and BPT trimpots.