

# **MM VCA**

## **Build Guide v1.1**

### **Dannysound**

**1 Introduction**

**2 Construction Tips**

**3 Parts Lists**

**4 Outer Board**

**5 Pots Board**

**6 Panel Components and Final Assembly**

**7 Testing and Calibration**

**8 Modifications**

## 1 Introduction

The M.M. VCA is based on the classic design by Dr. Robert Moog as used in his first portable synthesiser.

The discreet design has inherent soft clipping characteristics when driven, that either add harmonics to a pure sine wave or conversely remove higher order harmonics when amplifying waves such as a Saw or Triangle. This has the effect of slightly boosting the fundamental frequency making sounds that are fatter and warmer than standard VCAs.



*Scope plots showing soft clipping characteristics.  
Top trace – VCA Output, Lower trace – VCA input.*

The module consists of 2 VCAs in series (PRE-AMP and MAIN AMP) that allow for modulation of the first VCA (PRE-AMP) with an LFO and the second (MAIN AMP) with an Envelope generator.

An OFFSET control provides a DC control voltage to the first VCA that can be used to bias the modulation, so it doesn't cut off when the LFO is in the negative part of its cycle. This control can be set to full if modulation of the first VCA is not being used.

### Features:

- 2 x Audio Input Level Controls – Adjusts audio input level – Starts soft clipping after approximately 50%.
- CV 1 (PRE-AMP) Level – Adjusts the amount of CV to VCA 1.
- CV 2 (MAIN AMP) Level – Adjusts the amount of CV to VCA 2 (Normalised to 10V).
- CV 1 OFFSET Amount – Adjusts the amount of DC bias control voltage to VCA 1.

### Connections:

- 2 x Audio Inputs
- CV 1
- CV 2
- 1 x Audio Output

## 2 Construction Tips

These tools come in very handy, especially if you do a lot of DIY projects. They should be available from most electronics hobbyist stores.

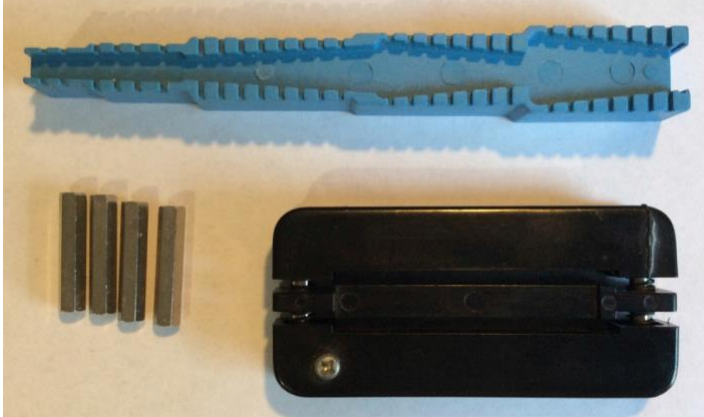

The blue bending gauge is for bending the resistor and diode legs to the right size.

The black IC straightener is for straightening pins of op-amps etc.

The silver standoffs are 25mm Female to Female.

You can use this setup with the 25mm standoffs for inserting the resistors and diodes.

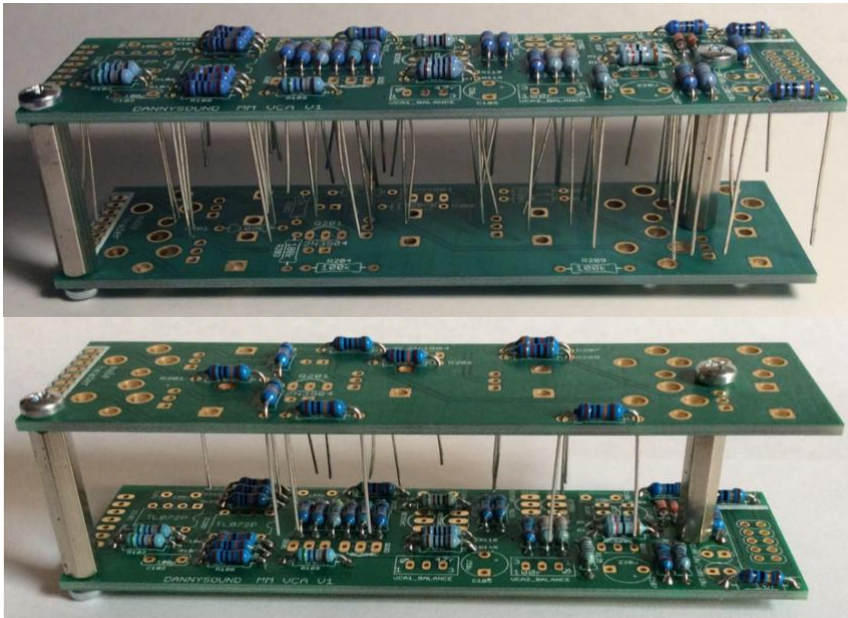

The top picture is for stuffing the Outer Board. It has the advantage of being much quicker to place all the resistors etc and it's easy to fix any mistakes. You can then solder everything from the top in one go (make sure you have decent temp. solder iron with not too fat tip!). Then unscrew the standoffs and clip all the legs. Reverse both boards as in the lower picture for the Pots Board.

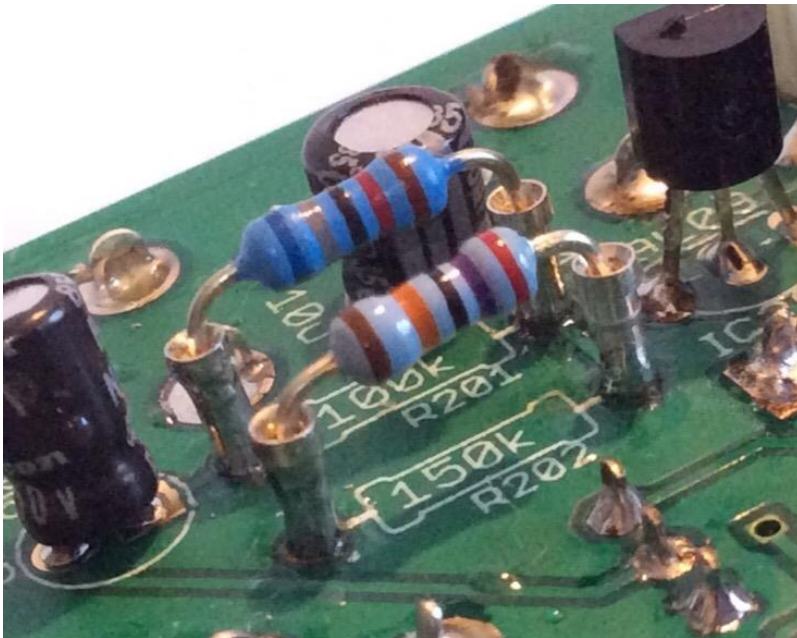

Cutting the pins from a SIL connector and soldering as shown above is useful for experimenting with different component values if you want to try out any of the modifications.

Note though that the Think kit contains all the parts you'll need for a well-functioning build, chosen to give you what we think is the best place to start.

### 3 Parts Lists

#### MM VCA OUTER V1

RESISTORS		
8r2	2	R126 R127
10r	2	R132 R133
100r	3	R118 R119 R129
150r	3	R120 R122 R128
180r	1	R125
330r	2	R123 R124
470r	1	R112
560r	1	R121
680r	2	R130 R131
820r	1	R117
1k	2	R108 R115
3k3	1	R111
6k8	1	R114
33k	1	R106
47k	1	R116
100k	5	R103 R104 R105 R107 R110
220k	1	R113
560k	3	R101 R102 R109

CAPS		
100p	2	C102 C103
100n	1	C101
330n	1	C106
680n	1	C104
10u	2	C108 C109
220u	2	C105 C107

DIODES		
1N4148	2	D101 D102

TRIM POTS		
47r	1	VCA1_BALANCE
100r	1	VCA2_BALANCE

OPAMPS		
TL072	2	IC101 IC102
<b>SOCKETS</b>		
8 pin DIL socket	2	

<b>TRANSISTORS</b>		
BC550	6	Q101 Q102 Q103 Q104 Q105 Q106
BC560	3	Q107 Q108 Q109

<b>HEADERS</b>	
1 X 8 FEMALE	1
2 X 5 SHROUDED POWER	1

<b>MM VCA POTS V1</b>
-----------------------

<b>RESISTORS</b>		
1k	2	R202 R205
33k	1	R207
82k	1	R208
100k	5	R201 R203 R204 R206 R209

<b>ALPHA POTS</b>		
100k LIN	2	AUD1 AUD2

<b>TALL TRIMMERS</b>		
100k LIN	3	CV1 CV2 OFFSET

<b>JACK SOCKETS</b>		
PJ301	5	AUD_IN1 AUD_IN2 CV_IN1 CV_IN2 O/P
<b>LEDs</b>		
3mm RED FLAT TOP	2	

<b>TRANSISTORS</b>		
2N3904	2	Q201 Q202

<b>HEADERS</b>	
1 X 8 MALE	1



### 4 Outer Board RESISTORS

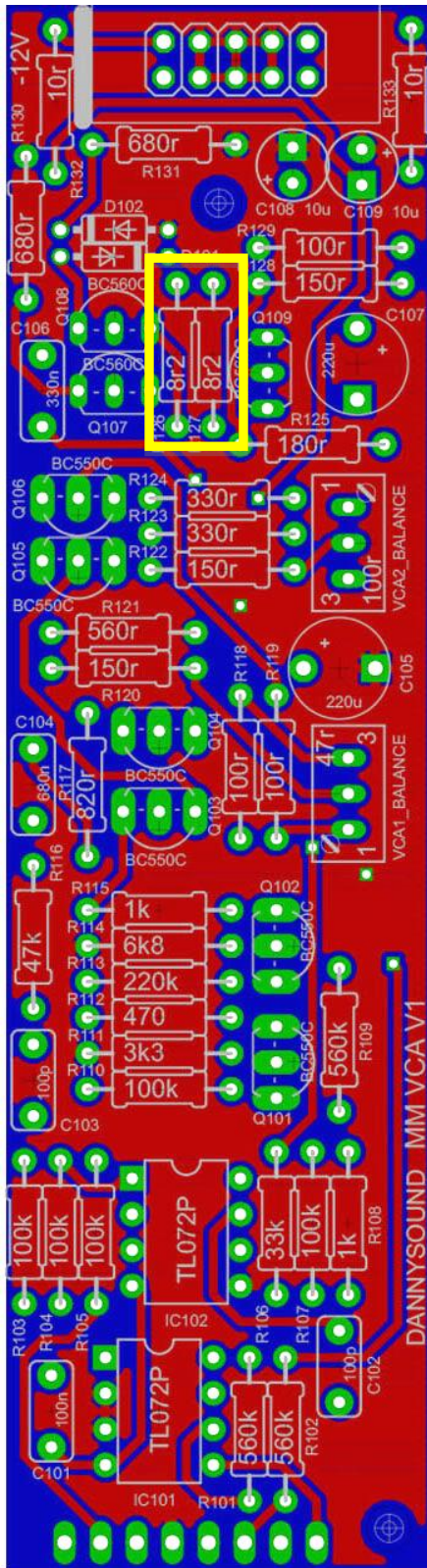

1) – 2 x 8r2 (R126, R127)

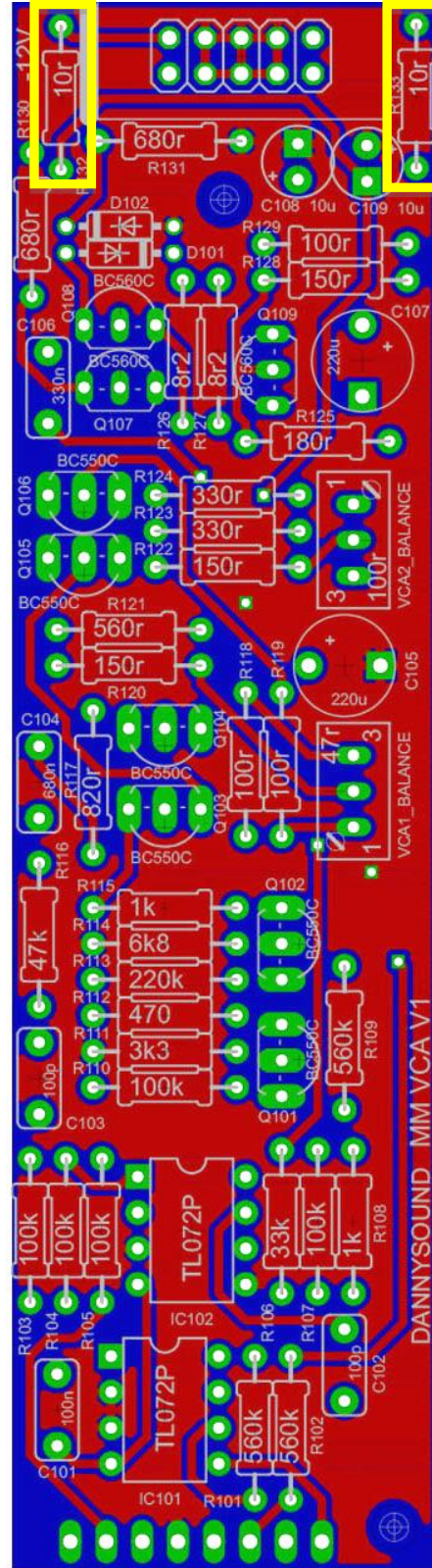

2) – 2 x 10r (R132, R133)



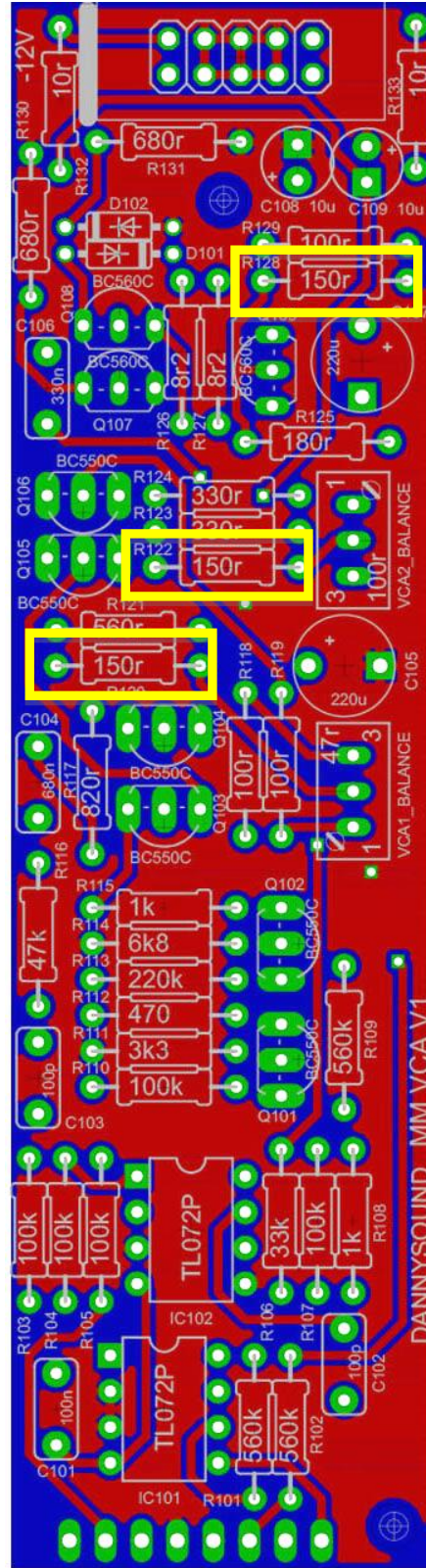
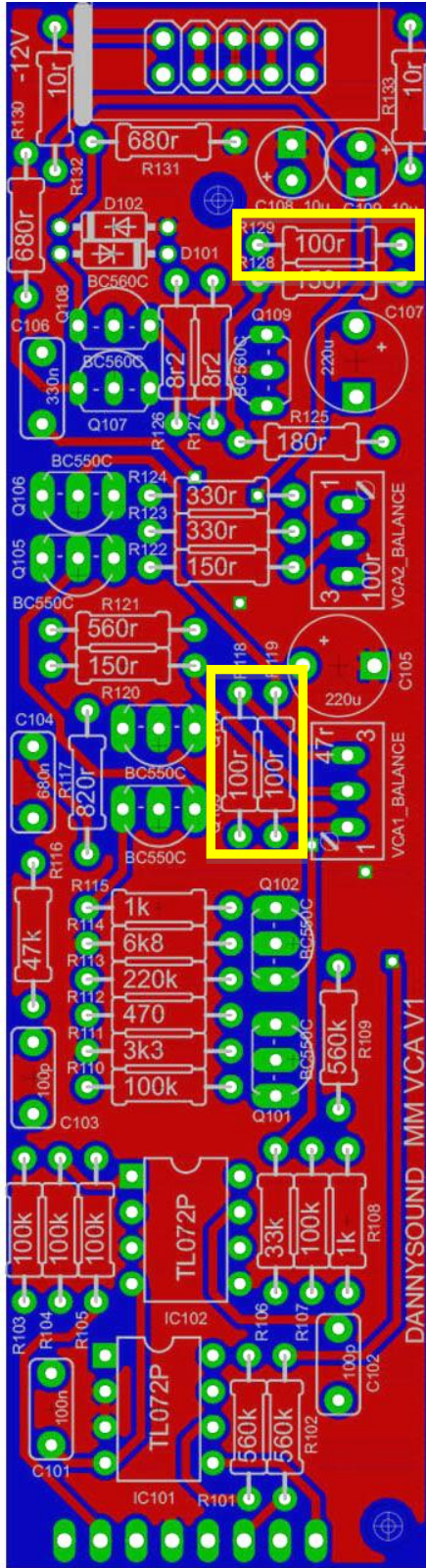

3) – 3 x 100r (R118, R119, R129)

4) – 3 x 150r (R120, R122, R128)



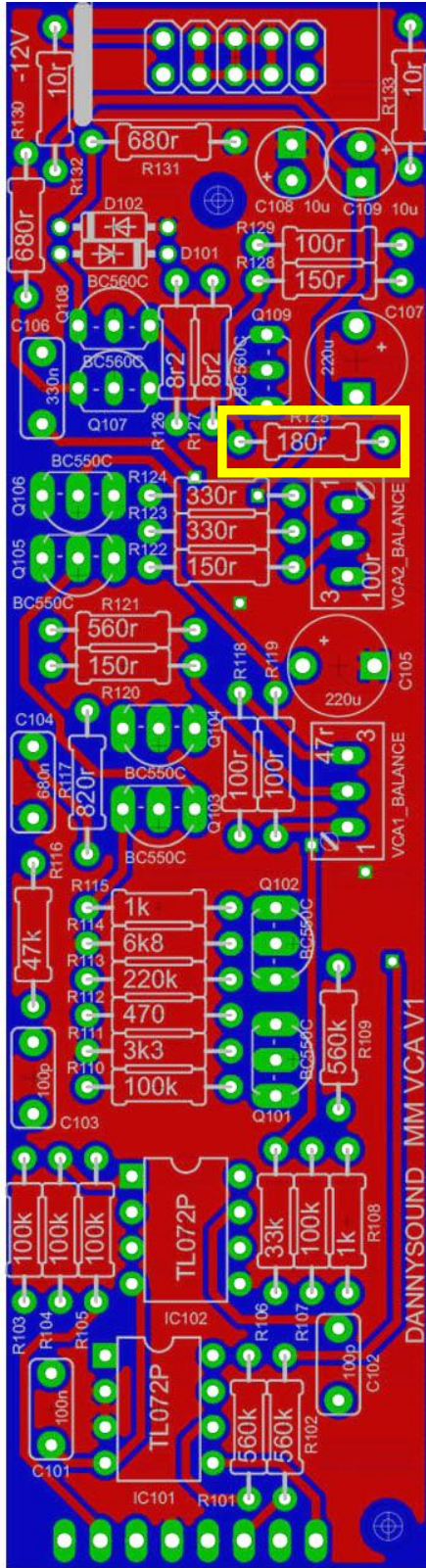

5) – 1 x 180r (R125)

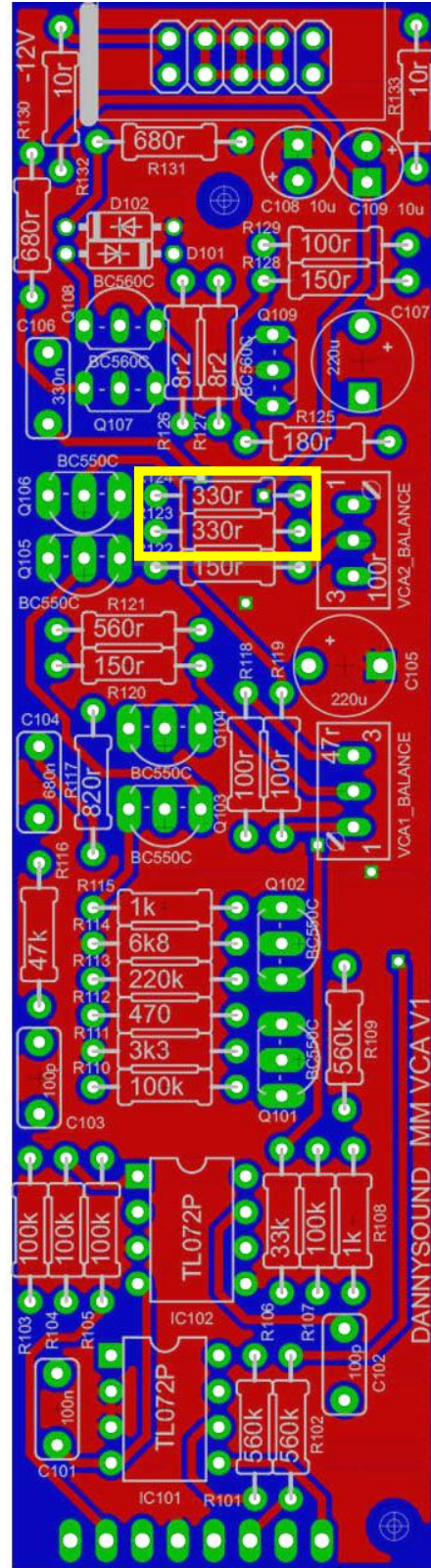

6) – 2 x 330r (R123, R124)

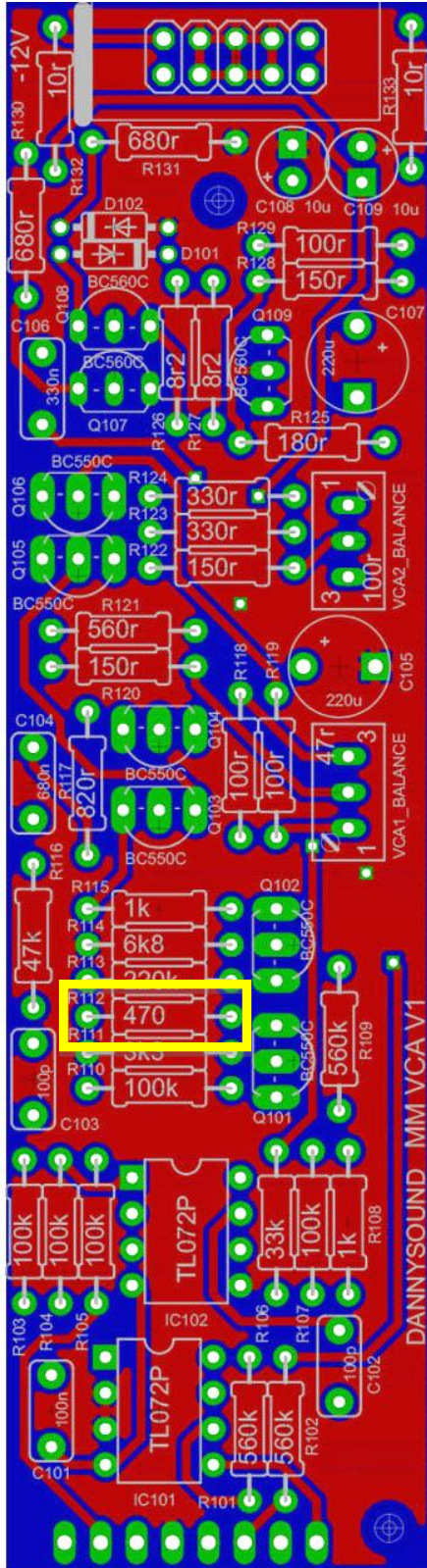

7) – 1 x 470r (R112)

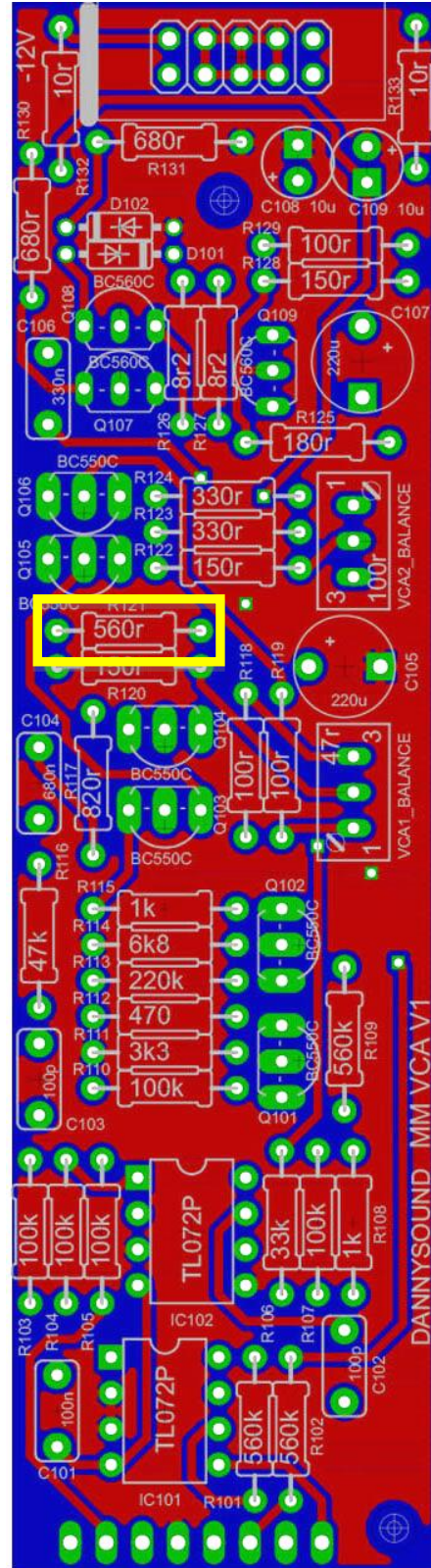

8) – 1 x 560r (R121)

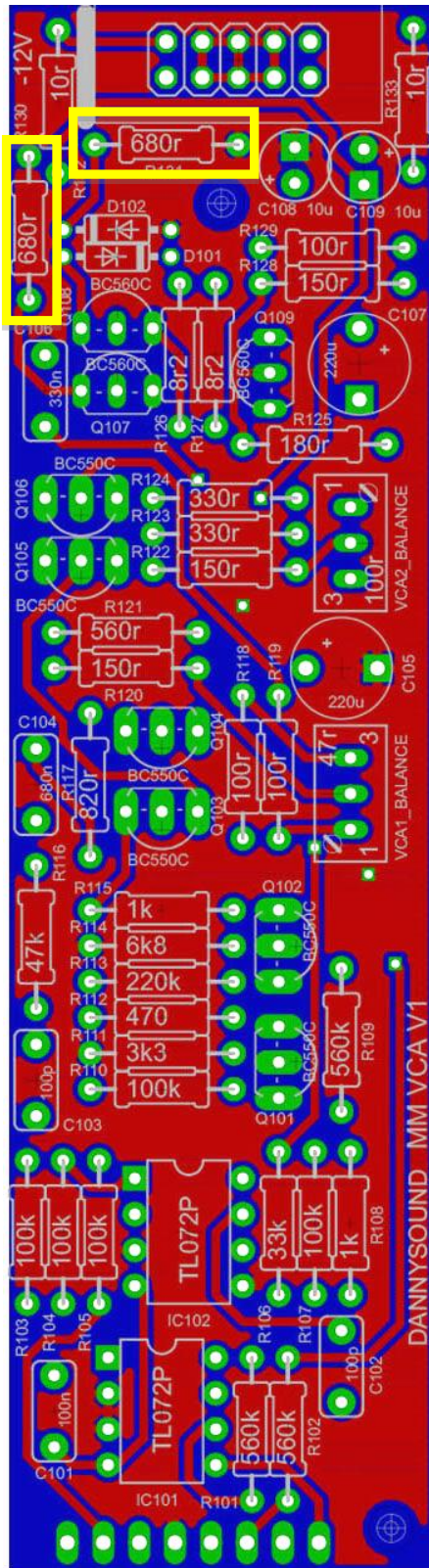

9) – 2 x 680r (R130, R131)

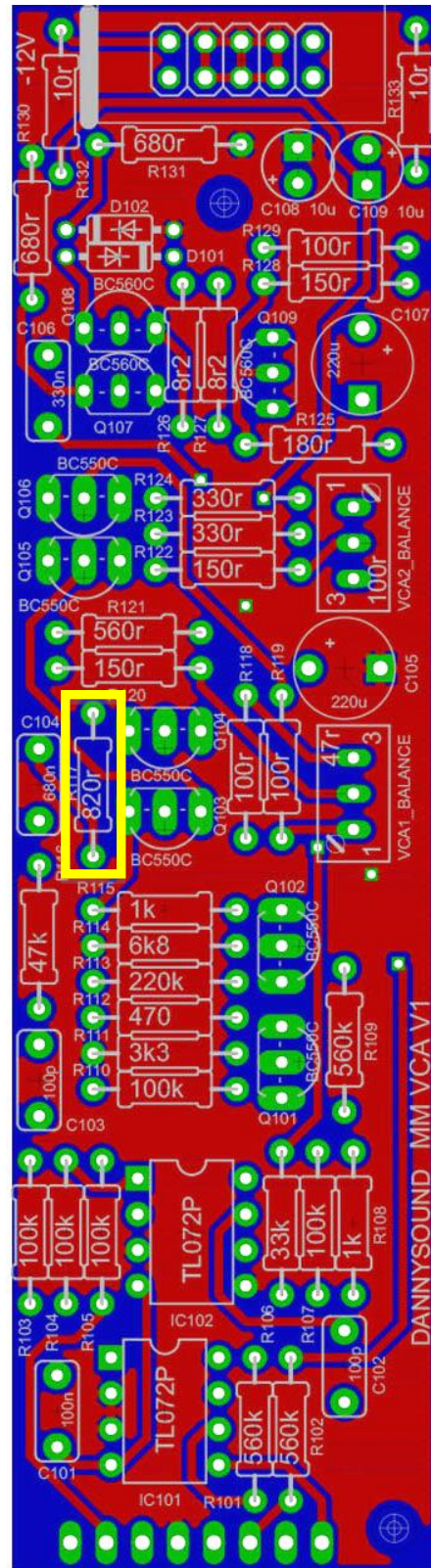

10) – 1 x 820r (R117)



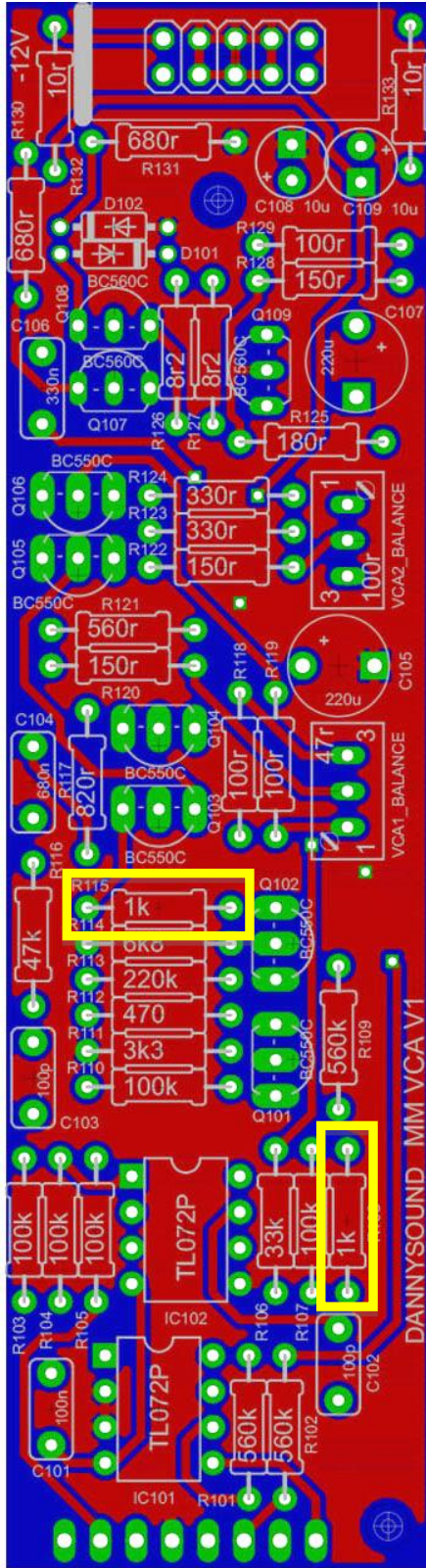

11) – 2 x 1k (R108, R115)

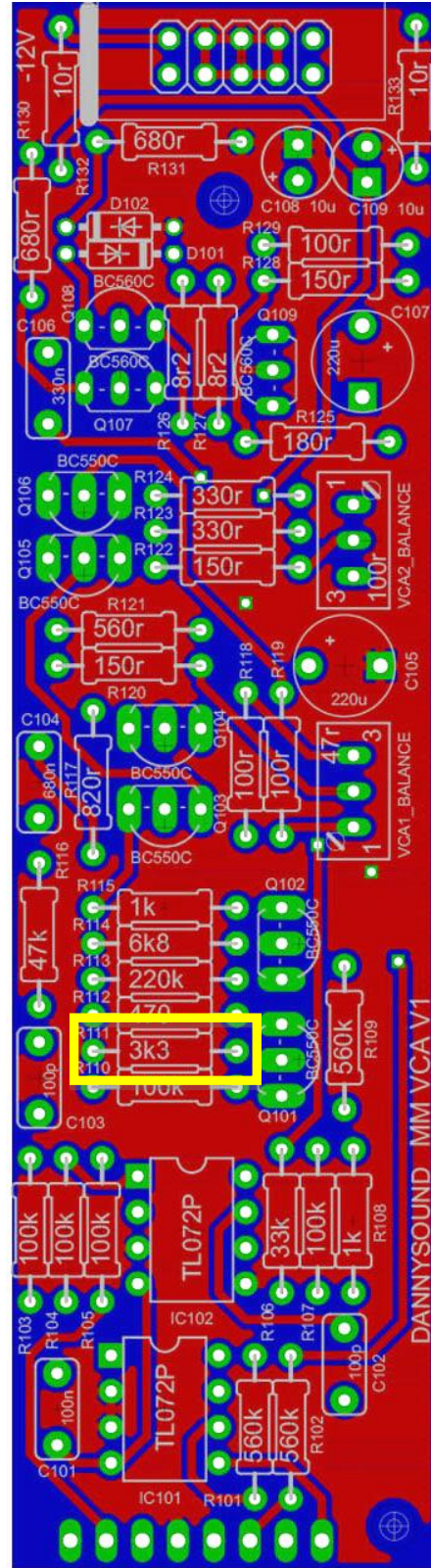

12) – 1 x 3k3 (R111)



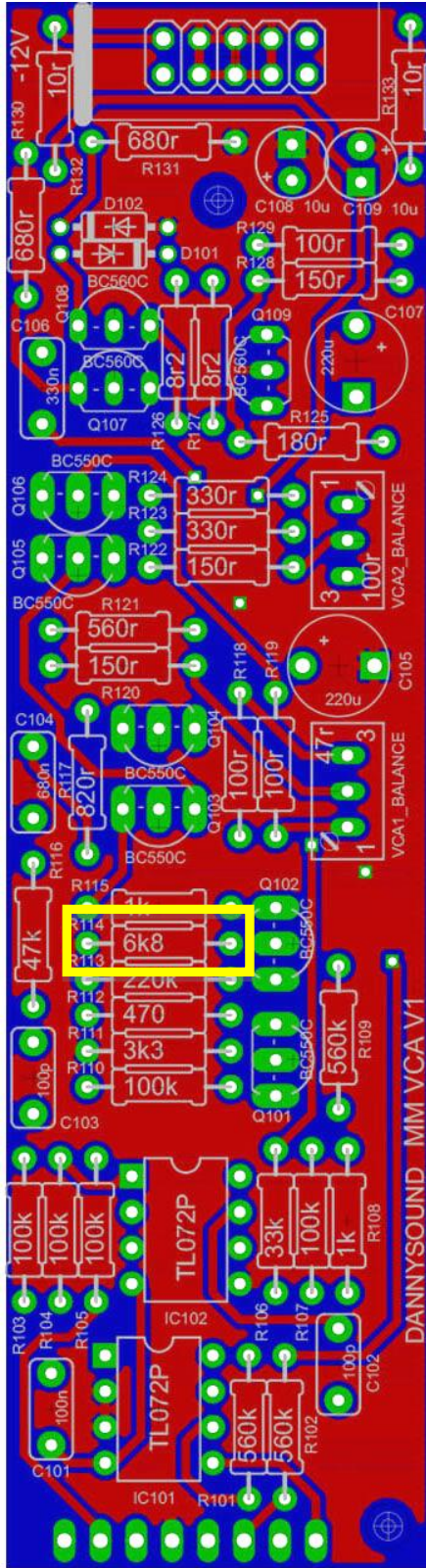

13) – 1 x 6k8 (R114)

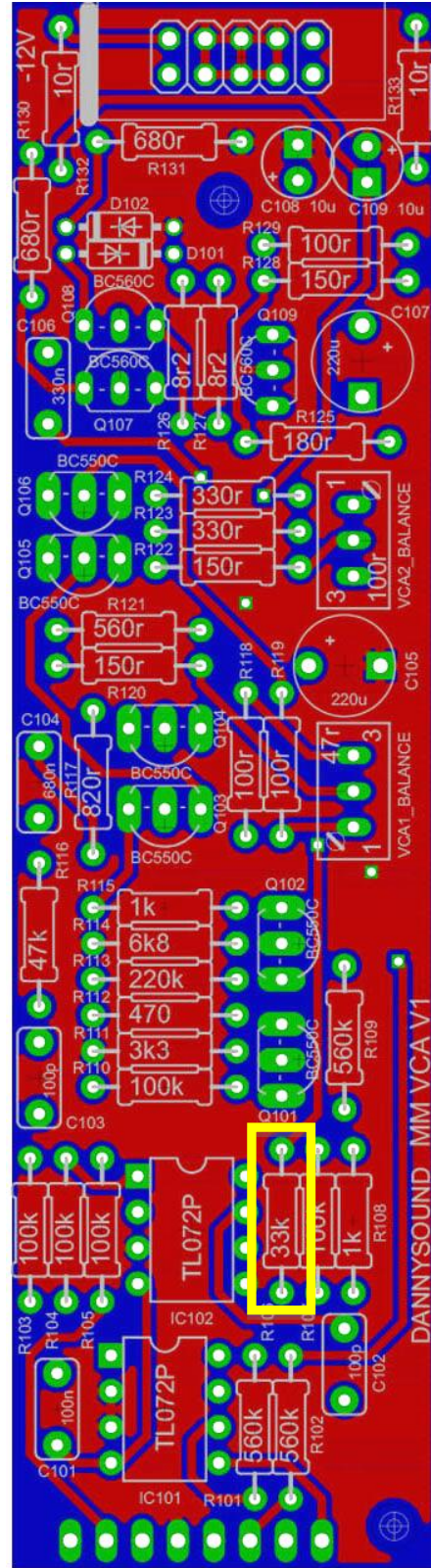

14) – 1 x 33k (R106)

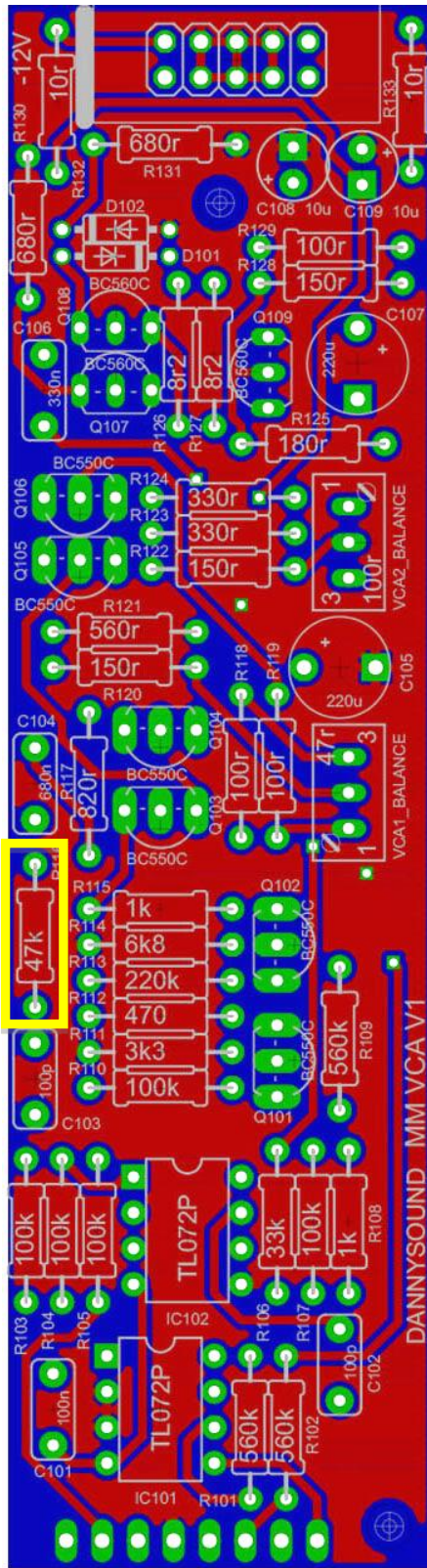

15) – 1 x 47k (R116)

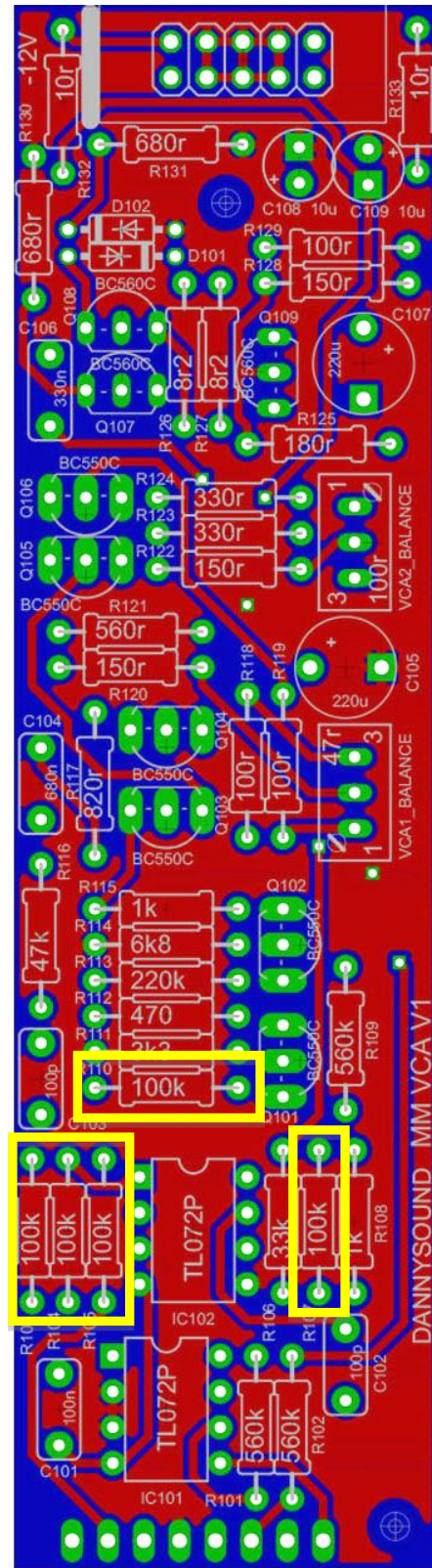

16) – 5 x 100k  
(R103, R104, R105, R107, R110)

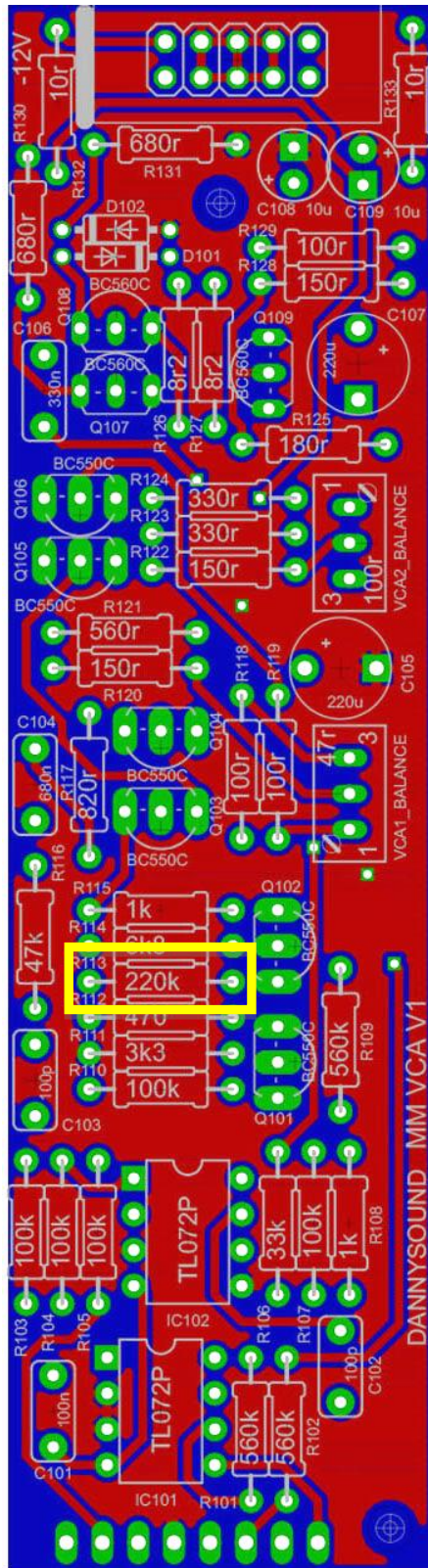

17) – 1 x 220k (R113)

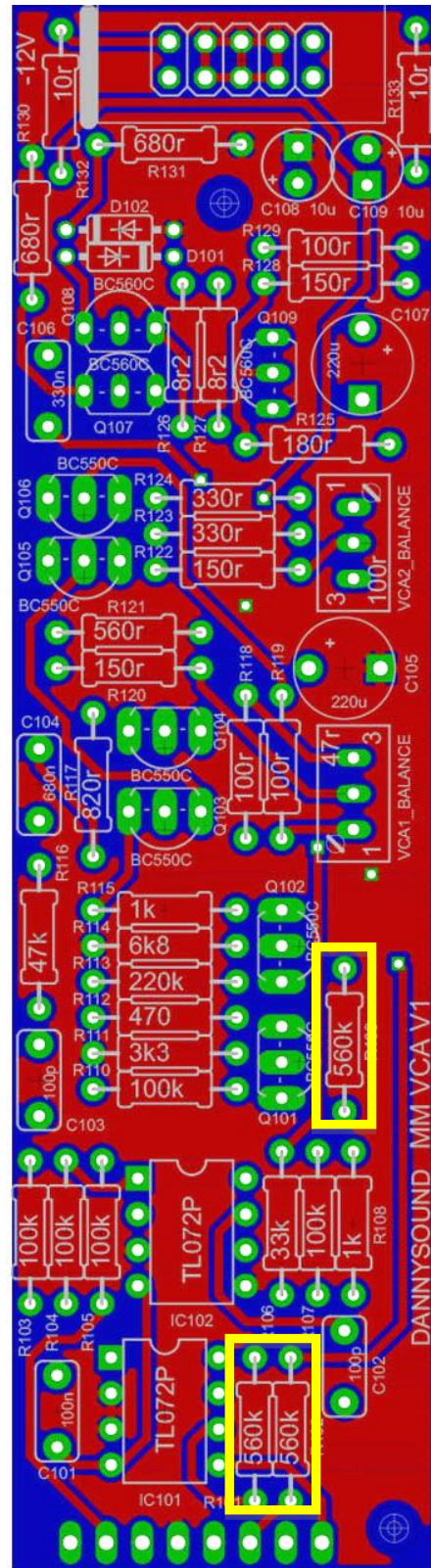

18) – 3 x 560k (R101, R102, R109)



DIODES

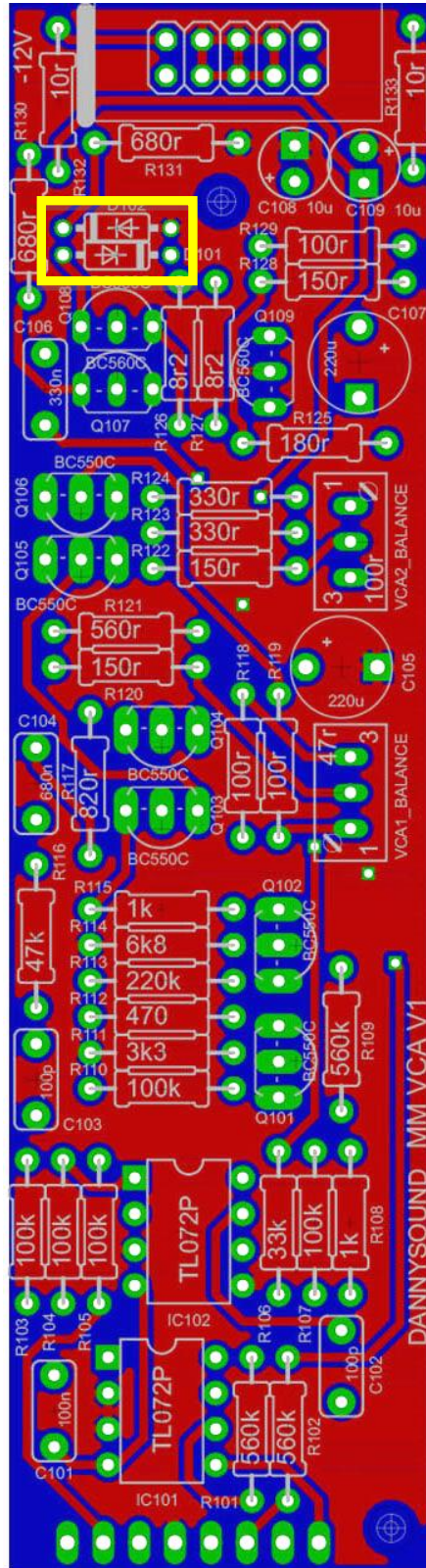

**19) – 2 x 1N4148 (D101, D102) NOTE:** orientation of this part is vital - be sure to match the line on the component with that on the PCB silkscreen



### SOCKETS

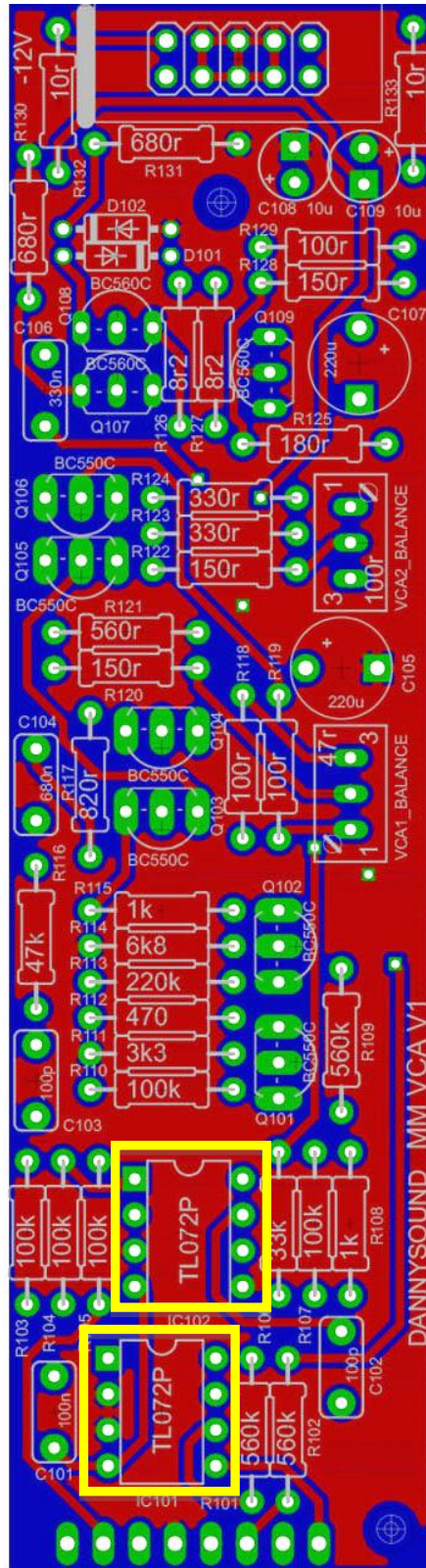

20) – 2 x 8 pin IC sockets - make sure the notches in the sockets match the notches on the PCB silkscreen.

CAPACITORS

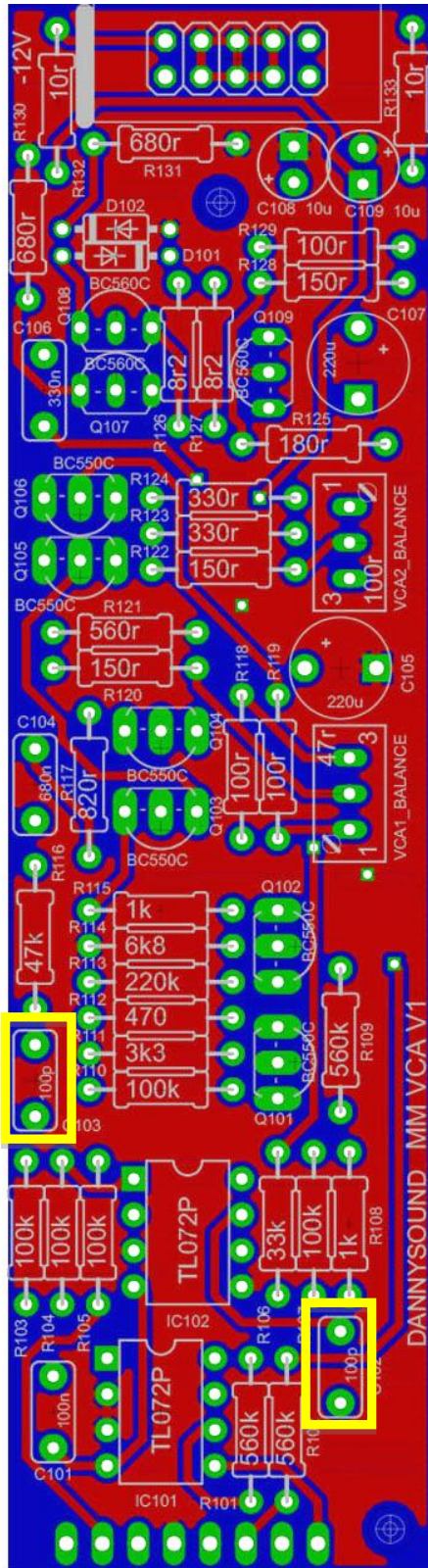

21) – 2 x 100p (C102, C103)

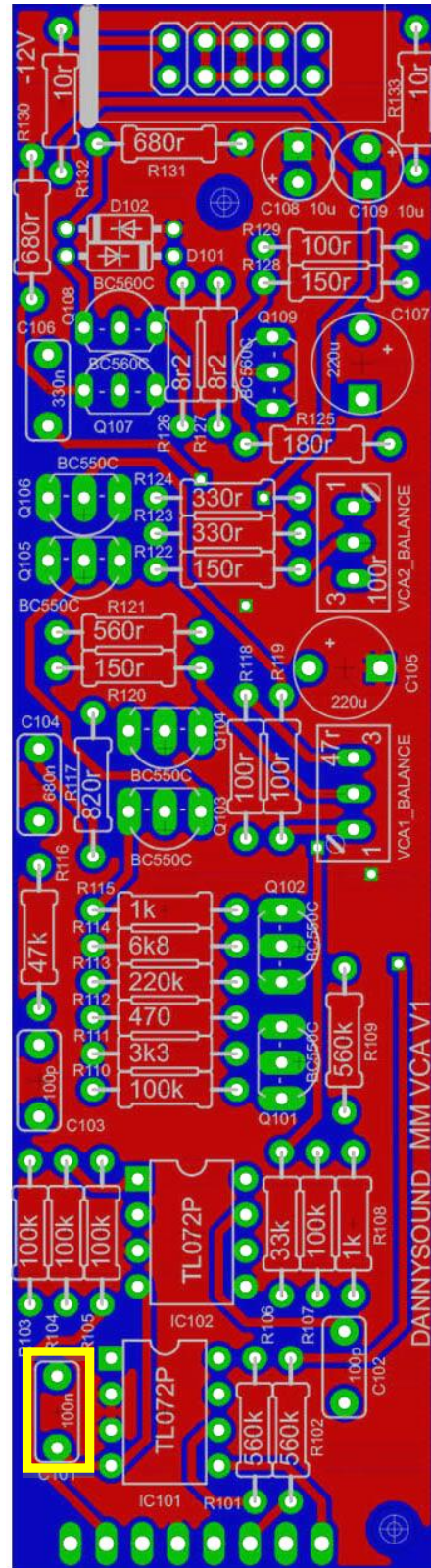

22) – 1 x 100n (C101)

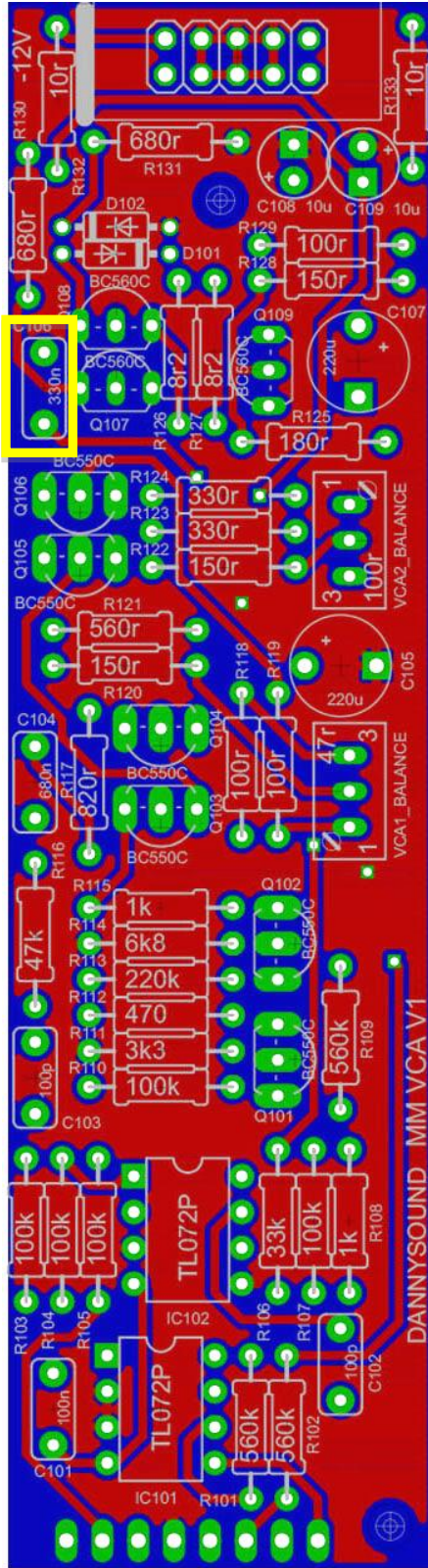

23) – 1 x 330n (C106)

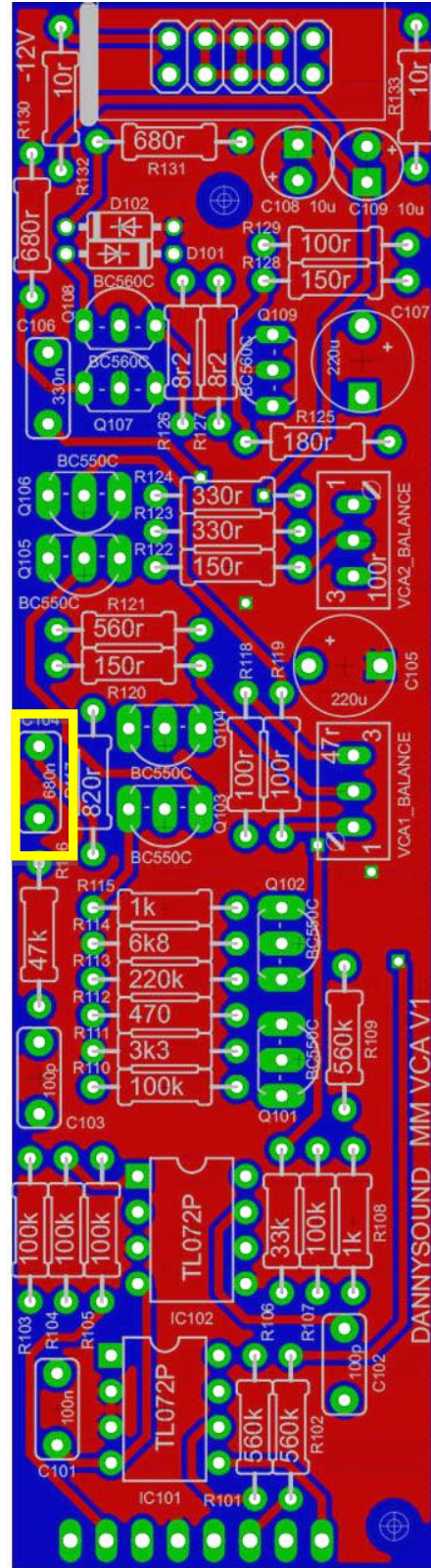

24) – 1 x 680n (C104)



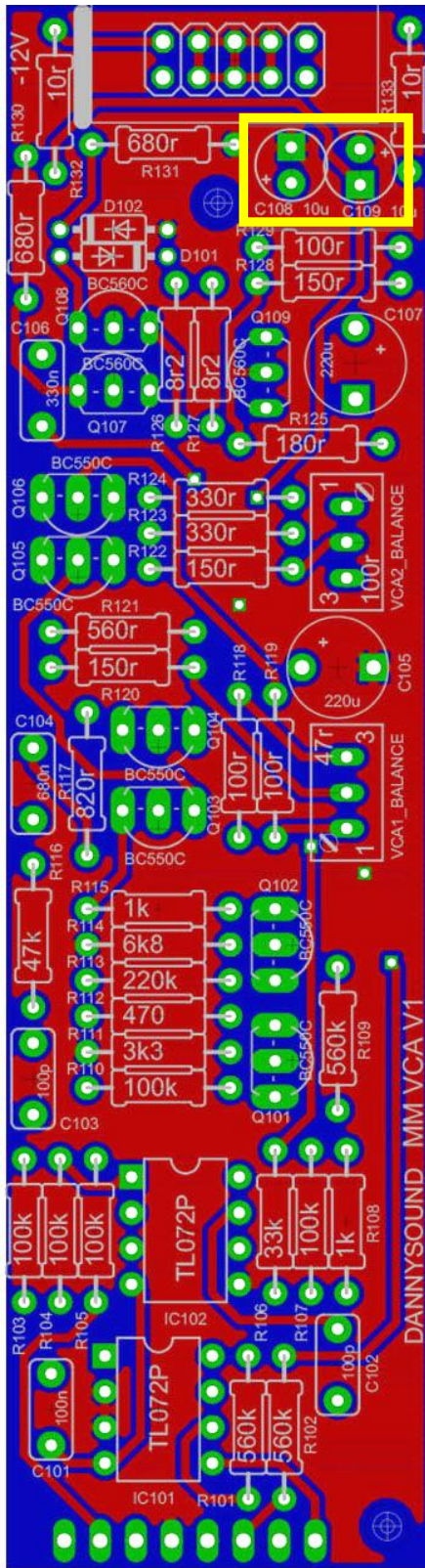

25) – 2 x 10u (C108, C109)

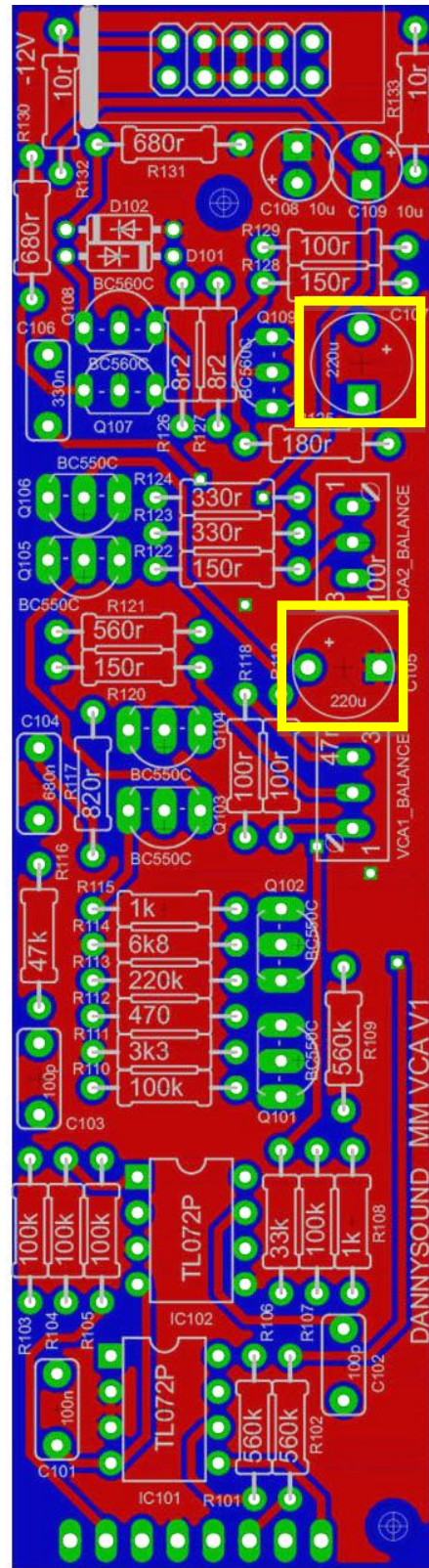

26) – 2 x 220u (C105, C107)

**NOTE:** orientation is vital for these four capacitors, the longer lead on the component must go to the circular pad marked with a plus '+' on the PCB. Note the component has a grey stripe on the cylindrical body on the minus side.



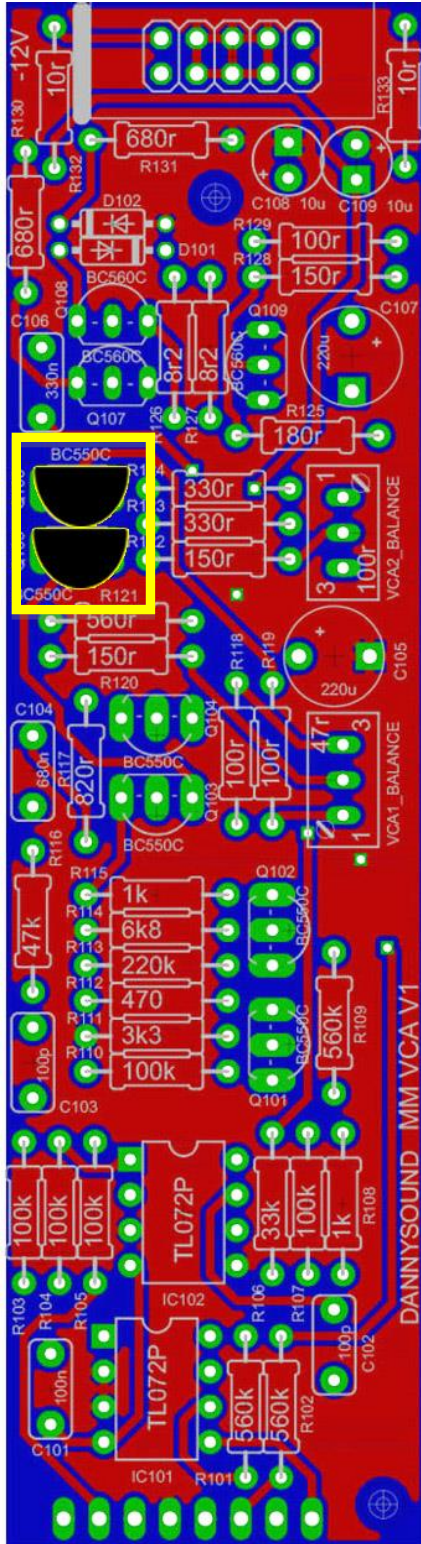

(Q103, Q104)

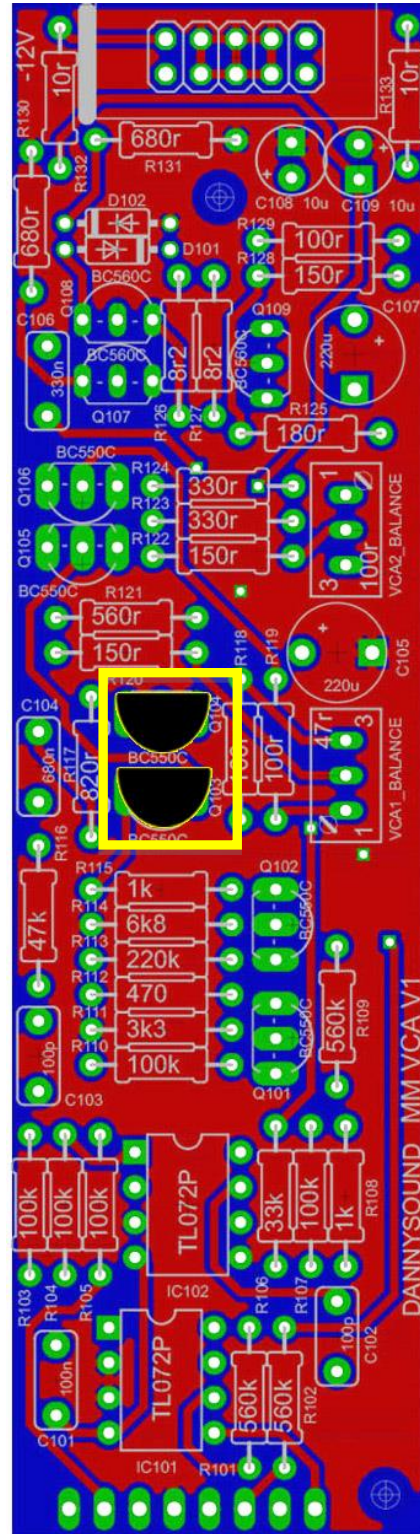

(Q105, Q106)

27) – 2 x MATCHED PAIR BC550 (packed with PCB set)

**NOTE!** Ensure the flat face on the components matches the flat face on the PCB silkscreen. Orientation is vital. **BE CAREFUL TO NOT SOLDER THE VERY SIMILAR LOOKING MATCHED BC560's IN THESE POSITIONS!**

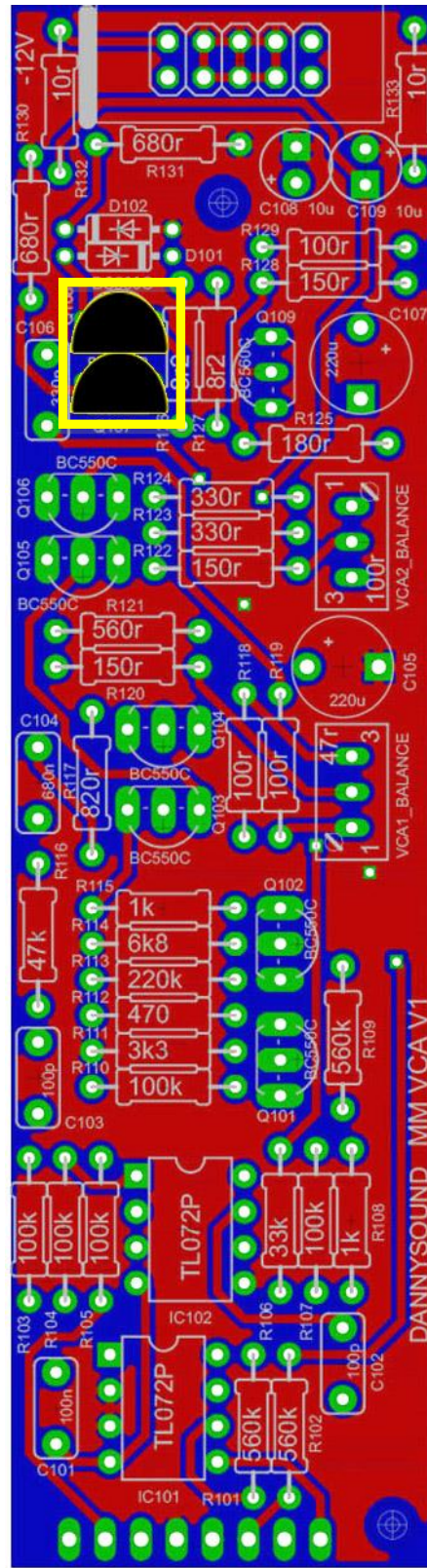

(Q107, Q108)

**28) – 1 x MATCHED PAIR BC560 (packed with PCB set)**

**NOTE!** Ensure the flat face on the components matches the flat face on the PCB silkscreen. Orientation is vital.



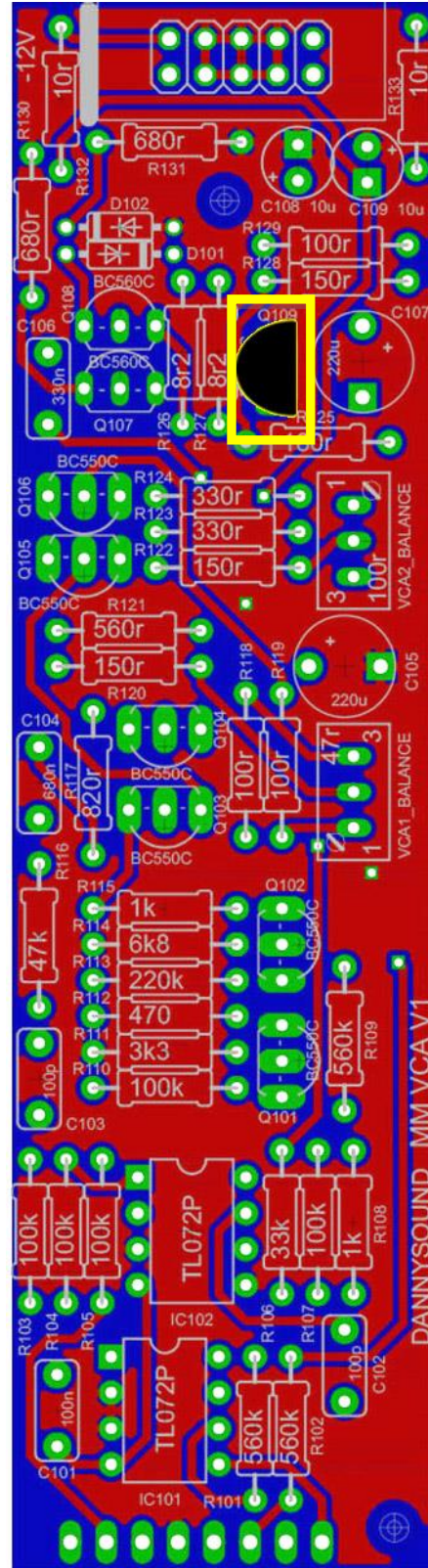
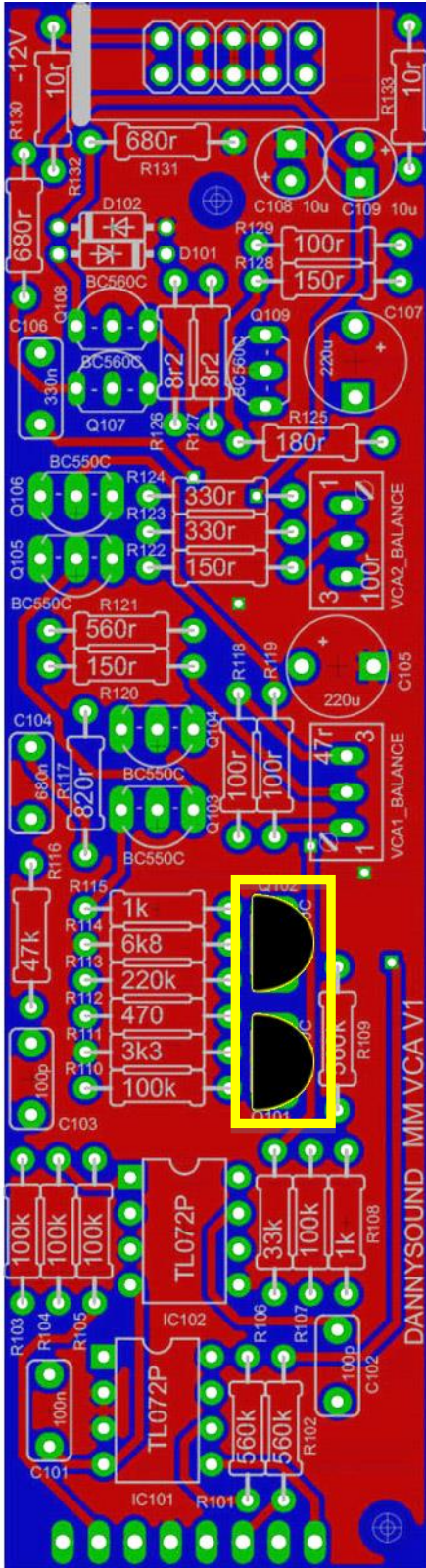

29) – 2 x BC550 (Q101, Q102)

30) – 1 x BC560 (Q109)

**NOTE!** Ensure the flat face on the components matches the flat face on the PCB silkscreen. Orientation is vital! **NOTE THESE ARE NOT THE 'MATCHED' PARTS!**



TRIM POTS

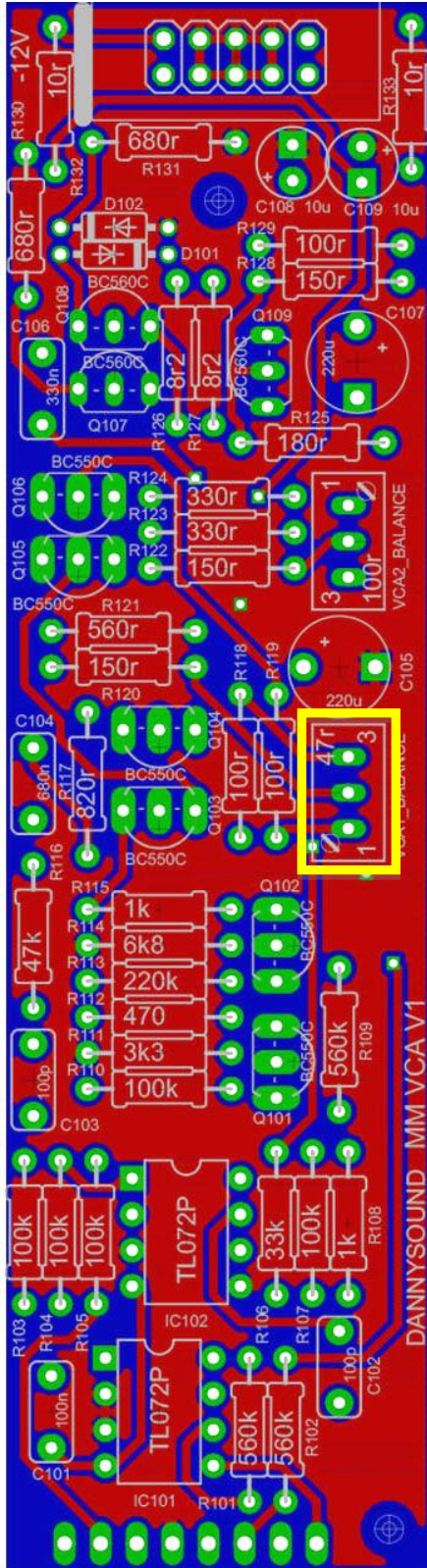

31) – 1 x 50r trimmer  
(PCB states 47r but 50r is correct)

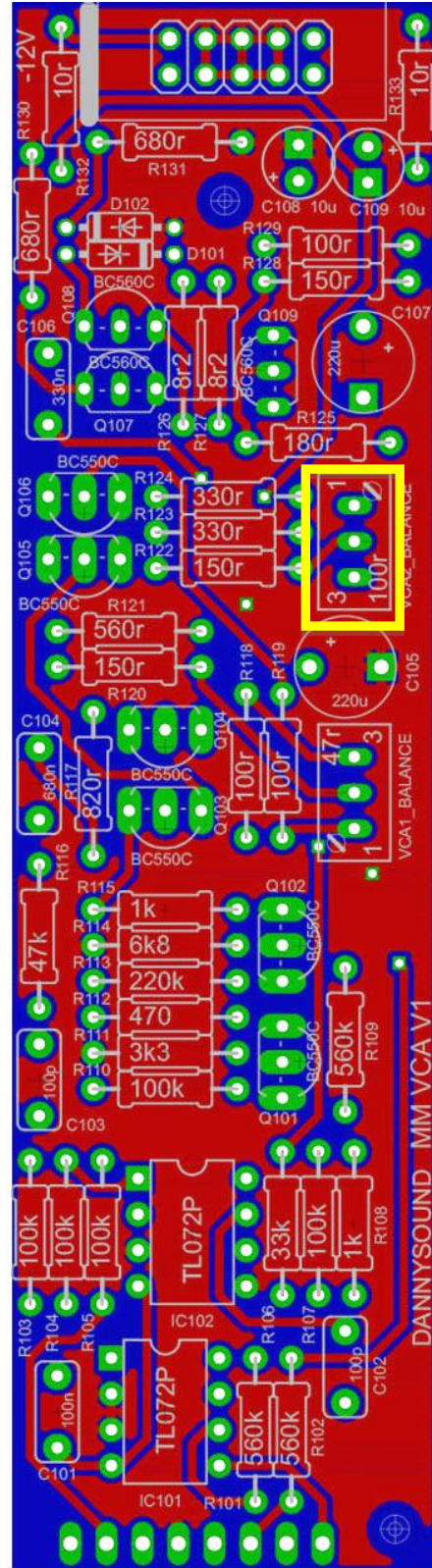

32) – 1 x 100r trimmer

HEADERS

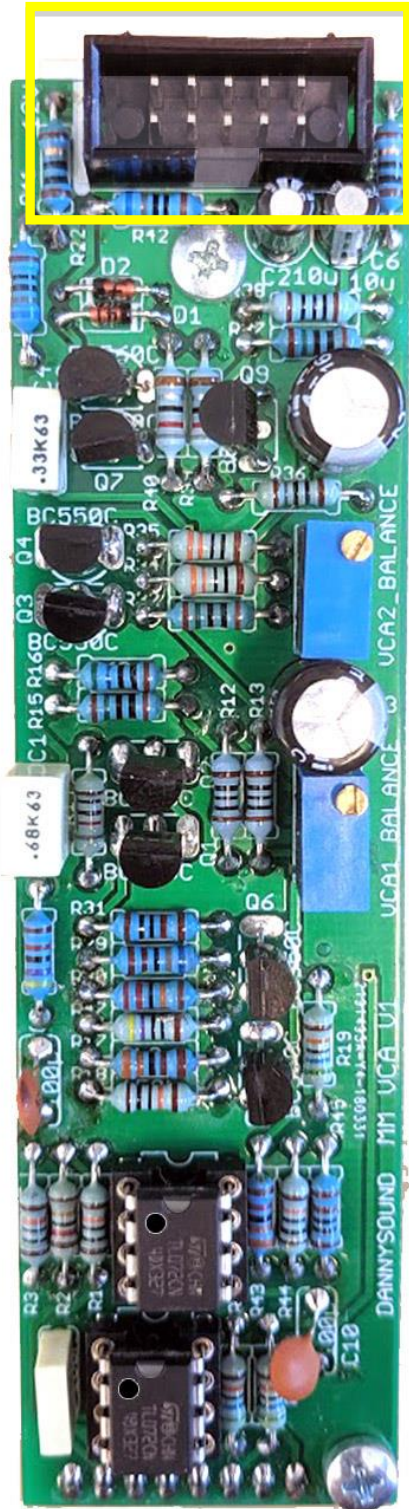

33) – 1 x SHROUDED 2x5 pin header - **make sure the slot is facing away** from the edge of the PCB as shown above. Orientation is vital!

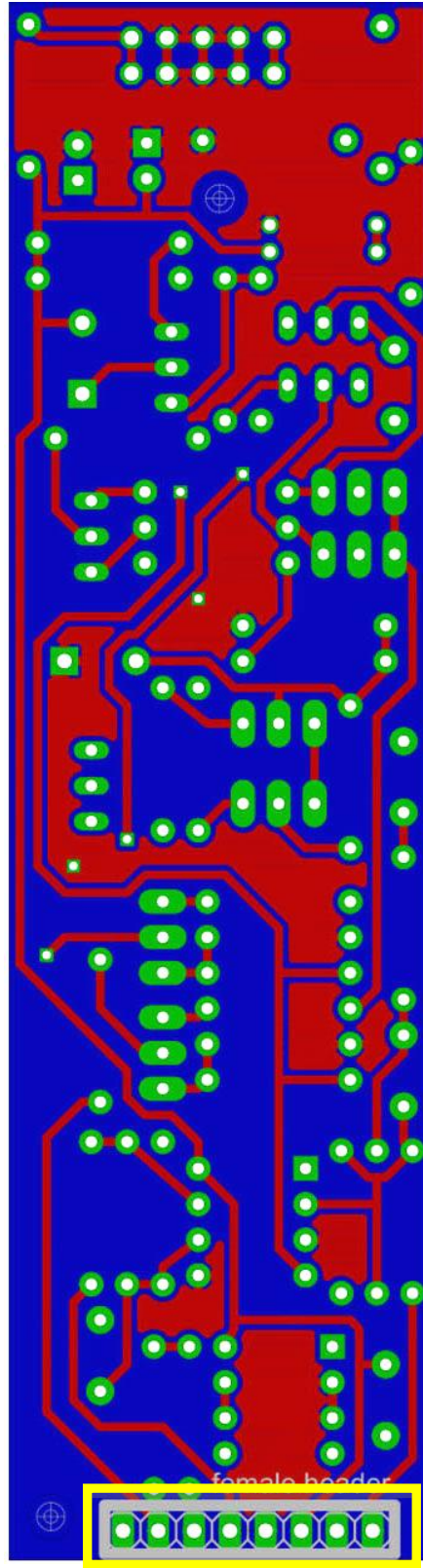

34) – 1 x FEMALE header 1x8 pin

**NOTE!** This header is placed on the **opposite side** of all the other components on this PCB!



ICs

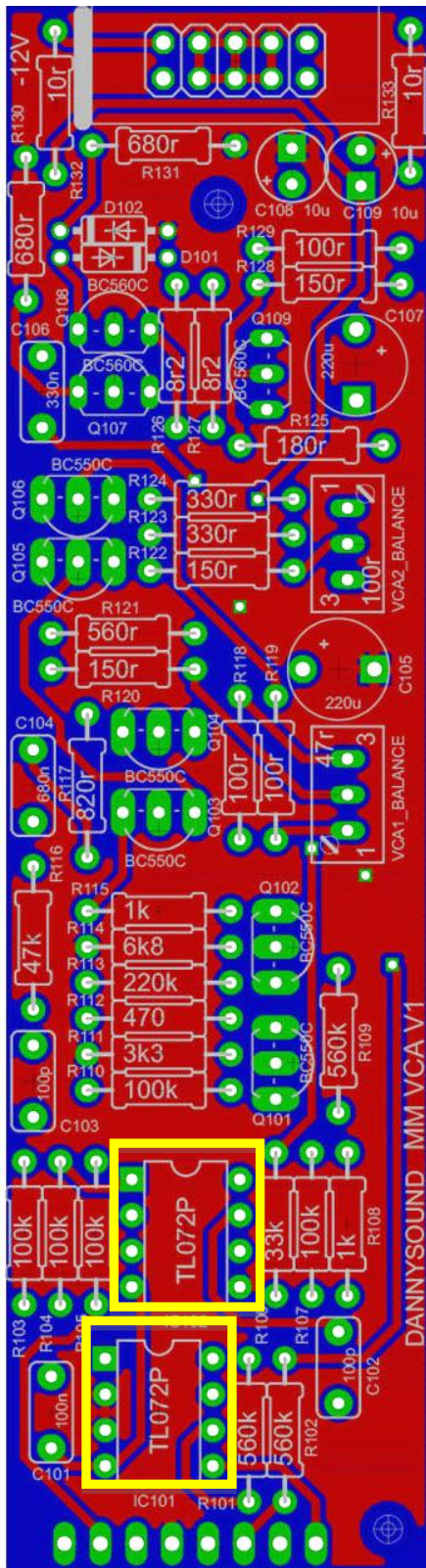

35) - 2 x TL072 opamps - orientation is vital, for these opamps match the dot with the notch on the PCB silkscreen and IC Socket

### 5 Pots Board RESISTORS

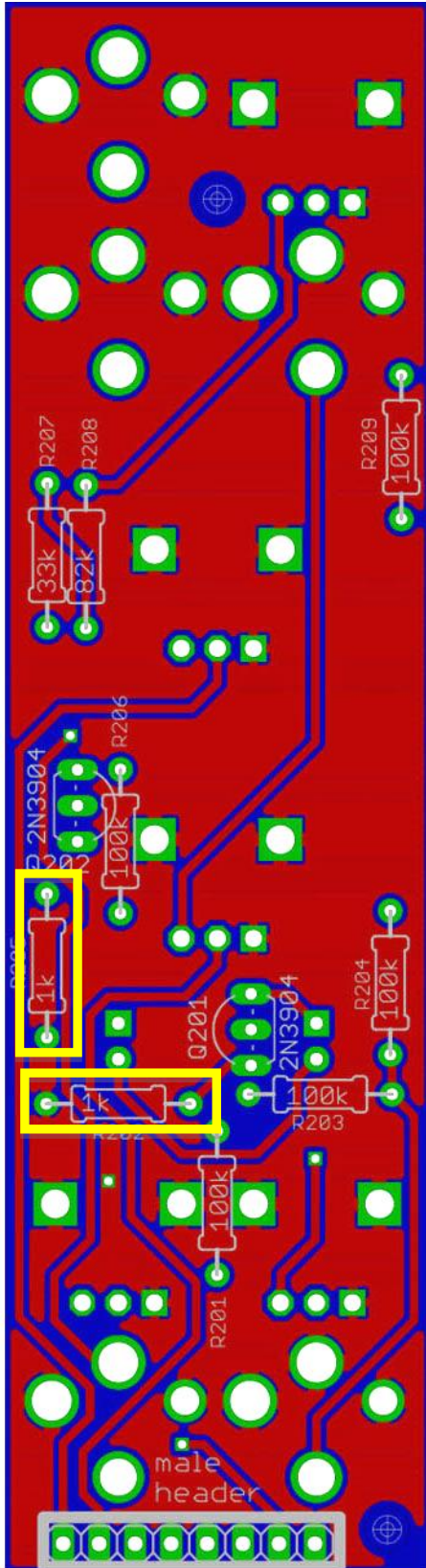

36) – 2 x 1k (R202, R205)

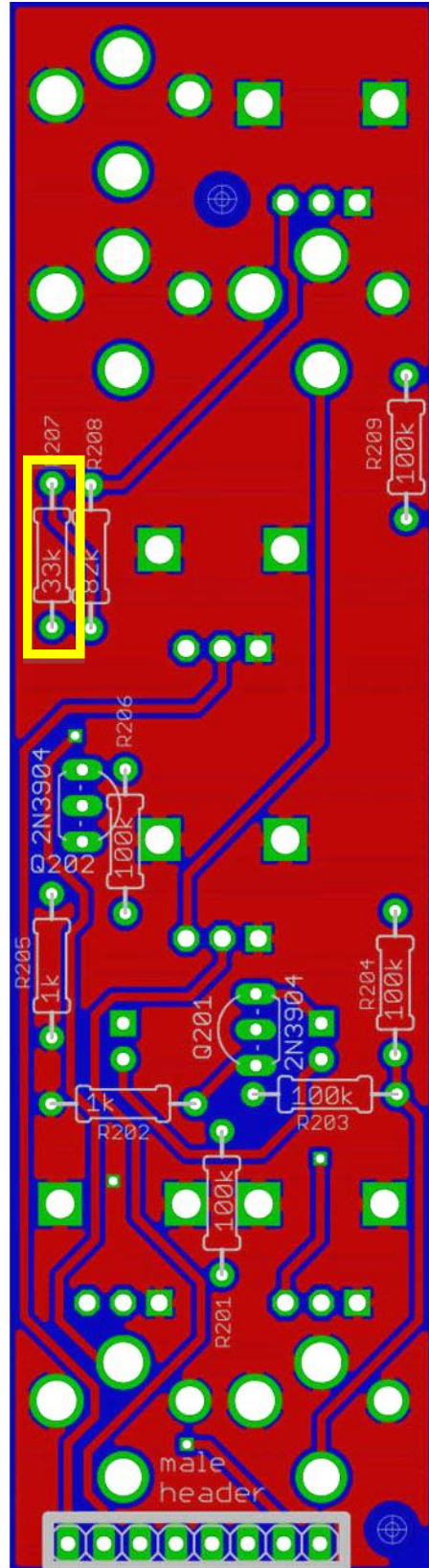

37) – 1 x 33k (R207)



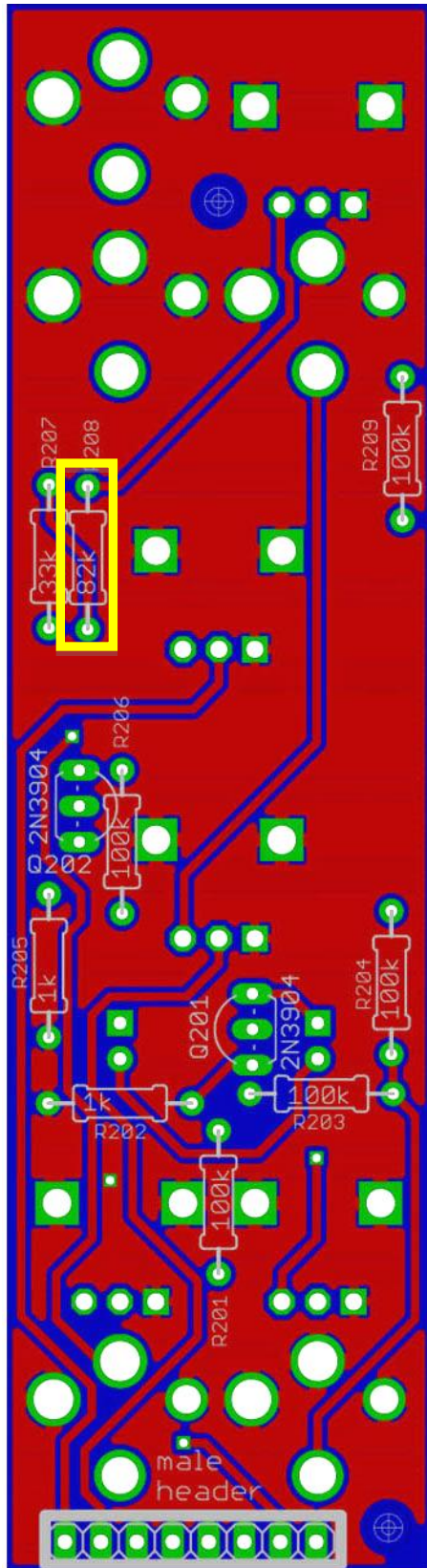

**38) – 1 x 82k (R208)**

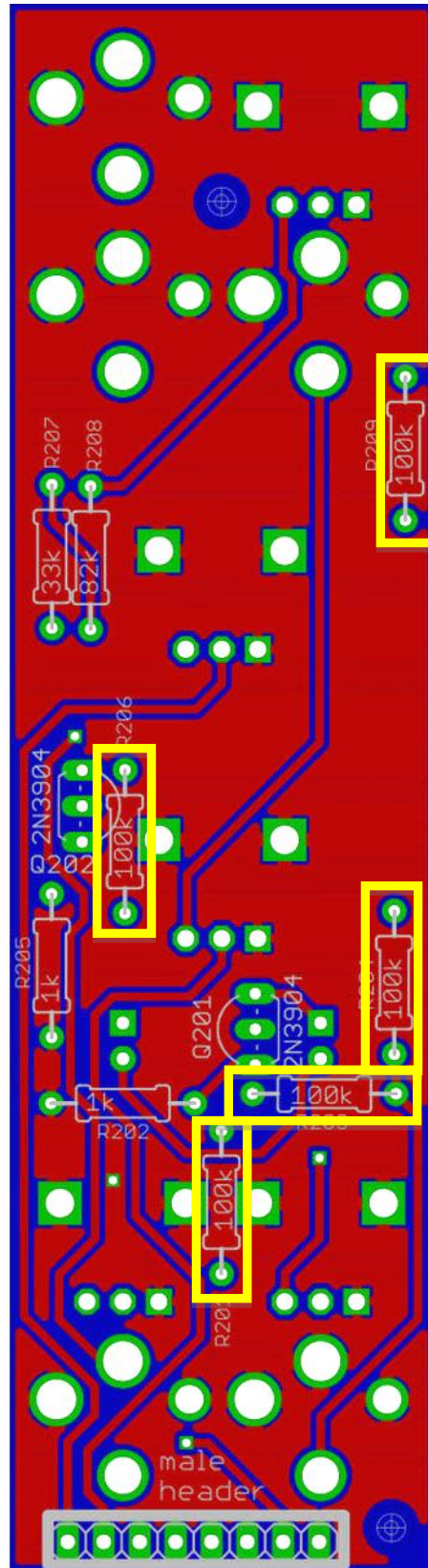

**39) – 5 x 100k  
(R201, R203, R204, R206, R209)**



## TRANSISTORS

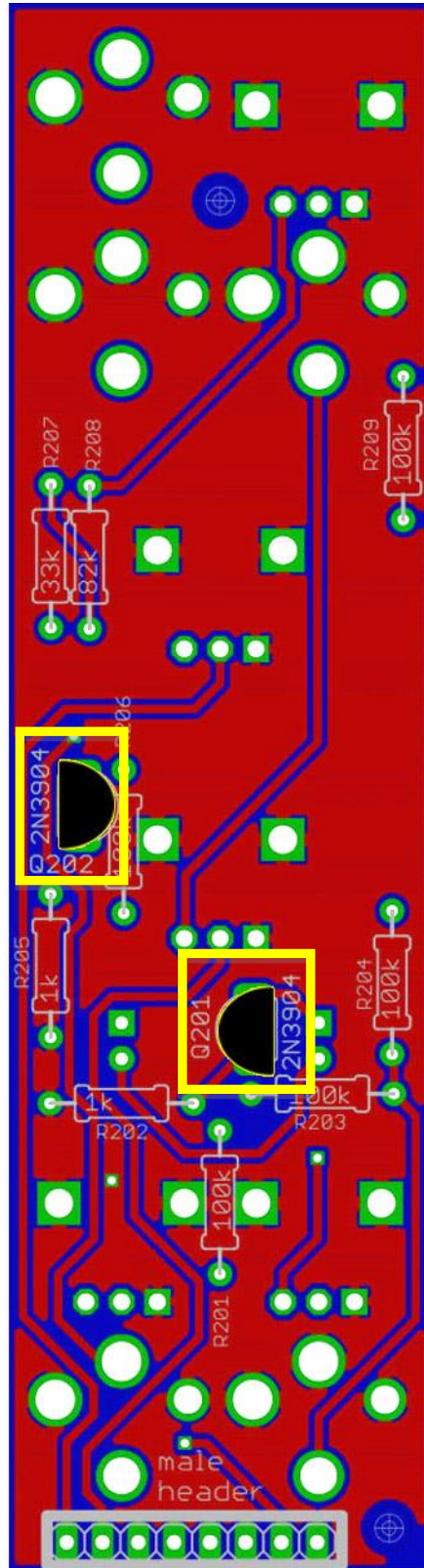

**40) - 2 x 2N3904 (Q201, Q202)**

**NOTE!** Ensure the flat face on the components matches the flat face on the PCB silkscreen. Orientation is vital!

HEADER

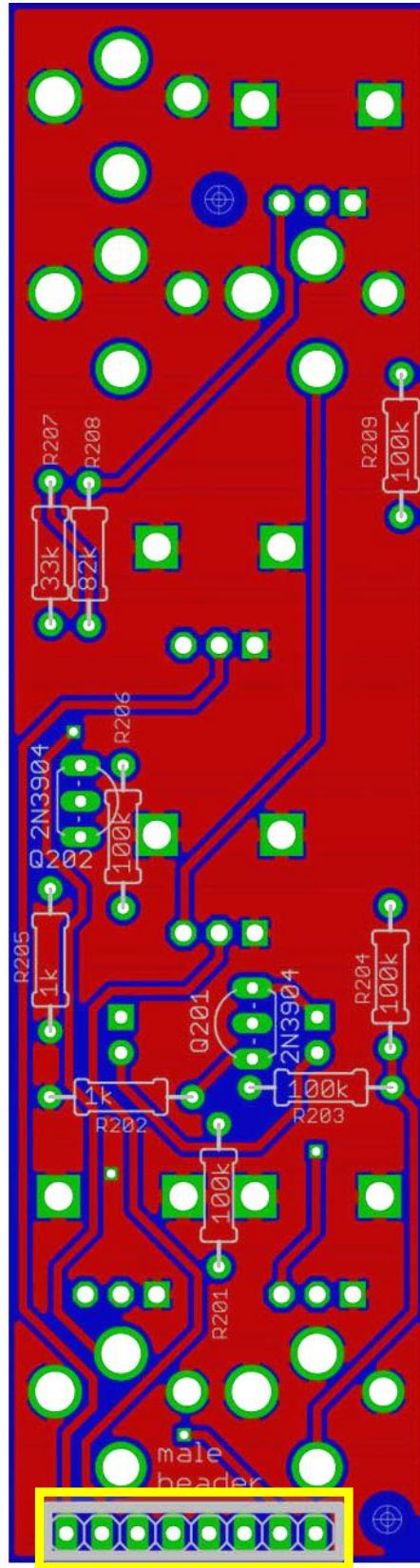

41) – 1 x MALE 1x8 pin header – this header is placed on the **same side** of the PCB as the resistors and transistors

STANDOFFS

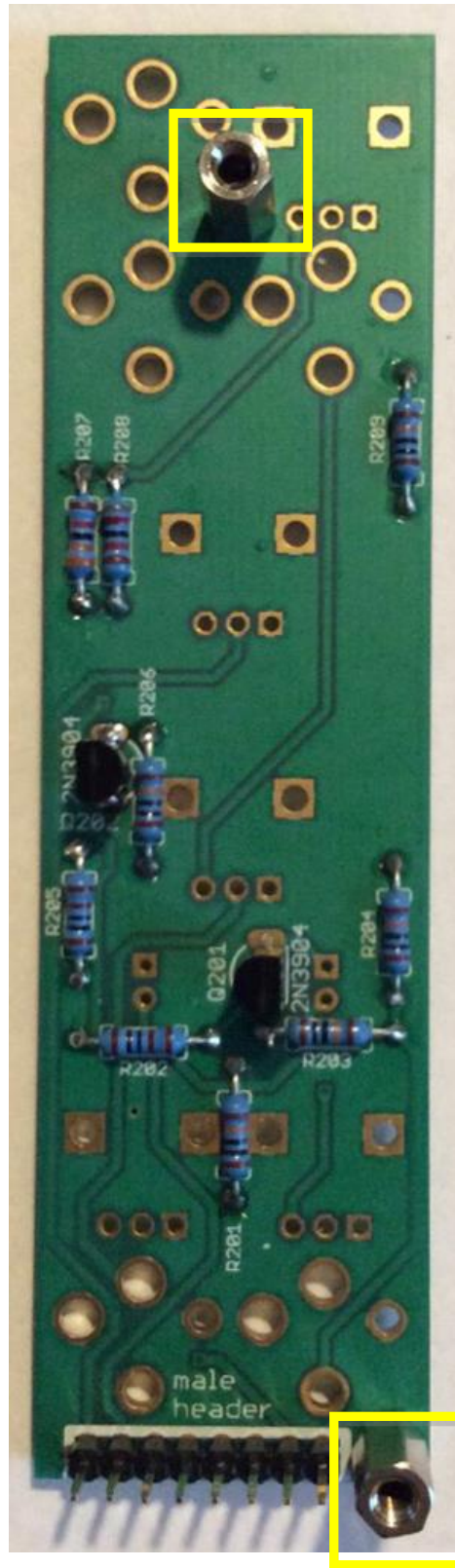

**42)** - **2** x Female to Female 11mm Standoffs – screw both standoffs to the PCB



## 6 Panel Components and Final Assembly

These components should be inserted but **NOT SOLDERED** until the panel has been placed on top. This is to ensure that the PCB fits the panel properly.



**43)** – Install 2 x Light pipes and retaining clips

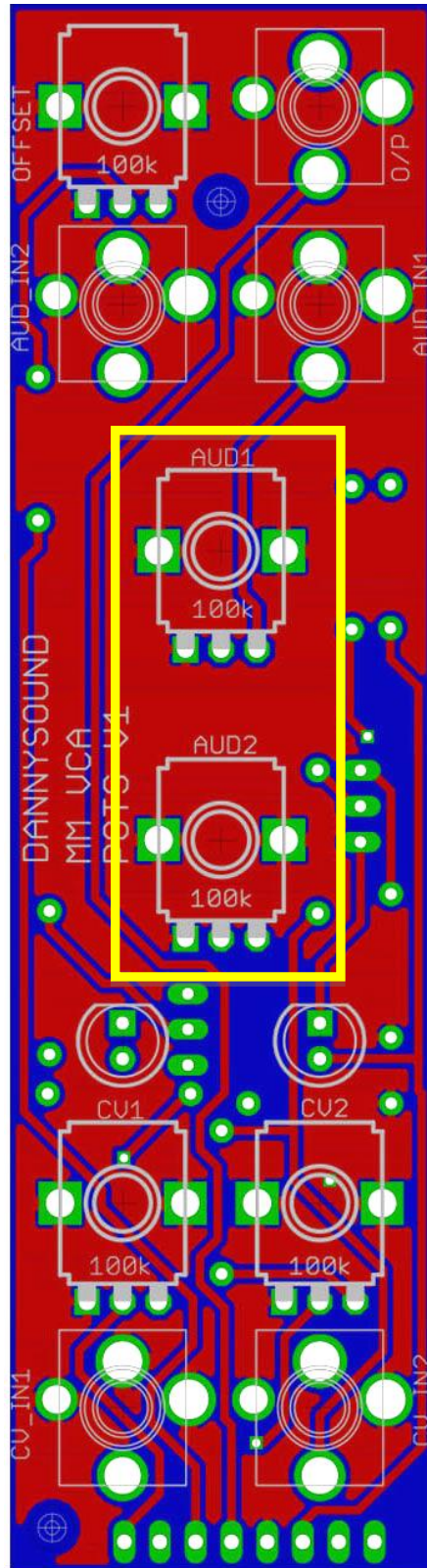

43) – 2 x B100k green body metal shaft pots



**B100K**

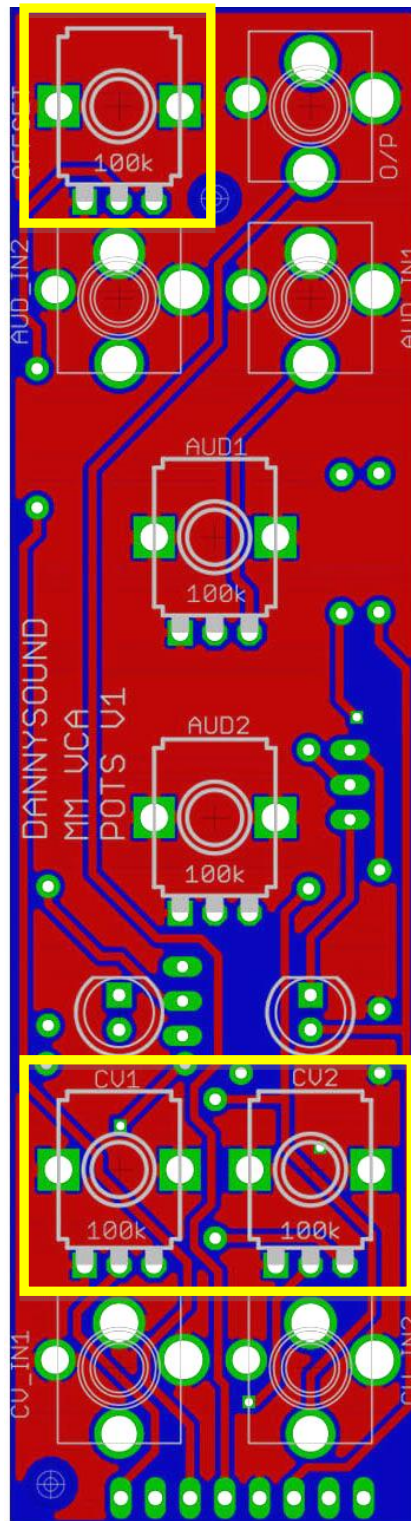

### B100K (B104)

44) – 3 x B100k (B104) blue body plastic shaft pots

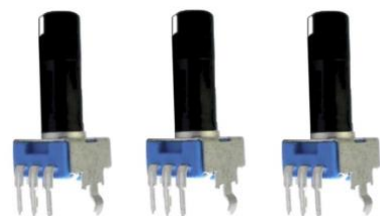



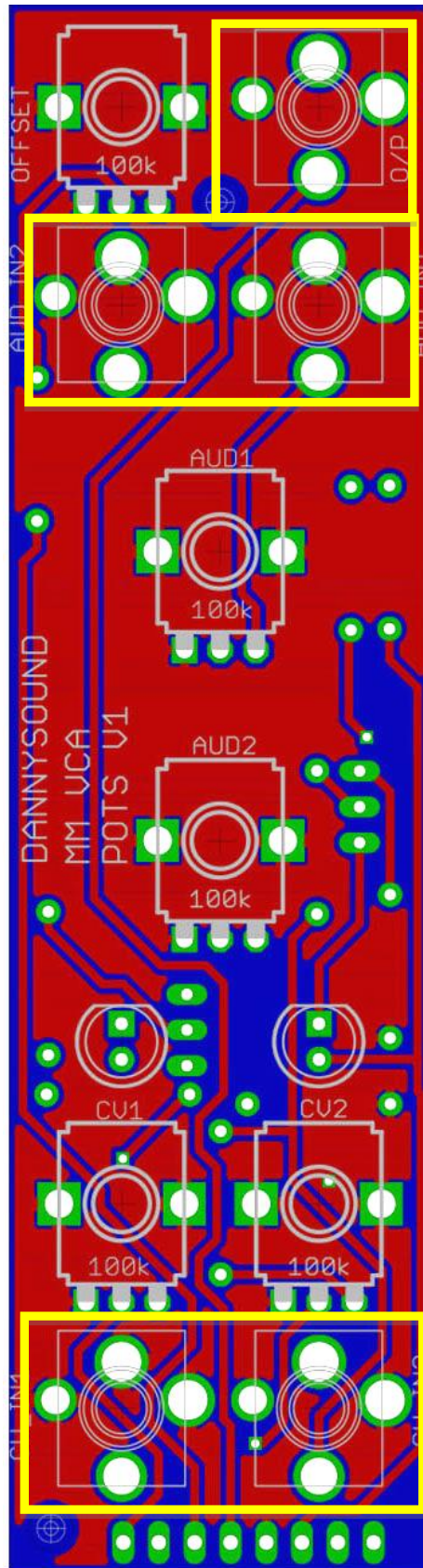

45) – 5 x Jack Sockets (PJ301BM or PJ398S-BM)

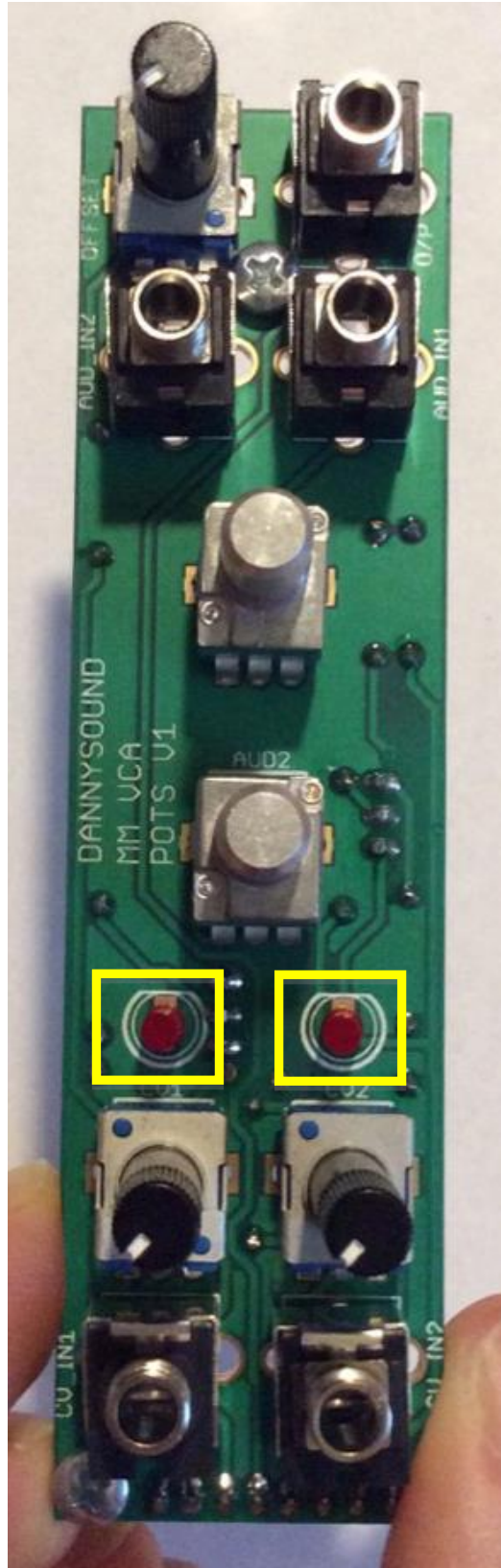

**46) – 2 x 3mm Red LEDs – NOTE:** orientation is vital, the shorter leg of the LED should go to the square pad and flat side of the PCB silkscreen diagram.

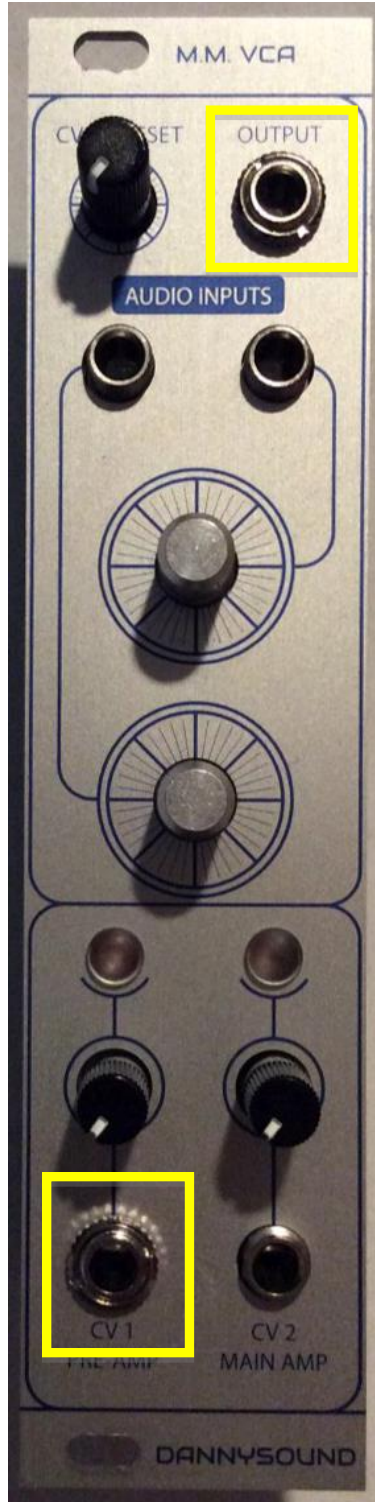

**47)** – Fit the panel in place, then while holding everything together turn over and solder one pin of the lower CV 1 jack socket and one pin of the output jack socket.

Ensure these sockets are pressed to the PCB properly (reflow the solder whilst applying pressure to the socket if it's not a snug fit) then attach the 2 nuts as shown above to keep everything in place.



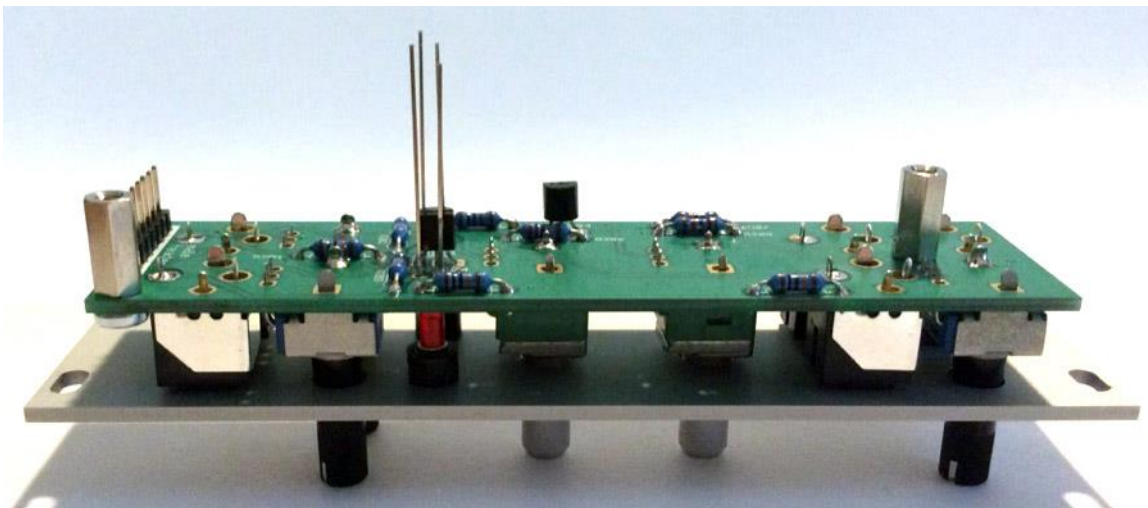
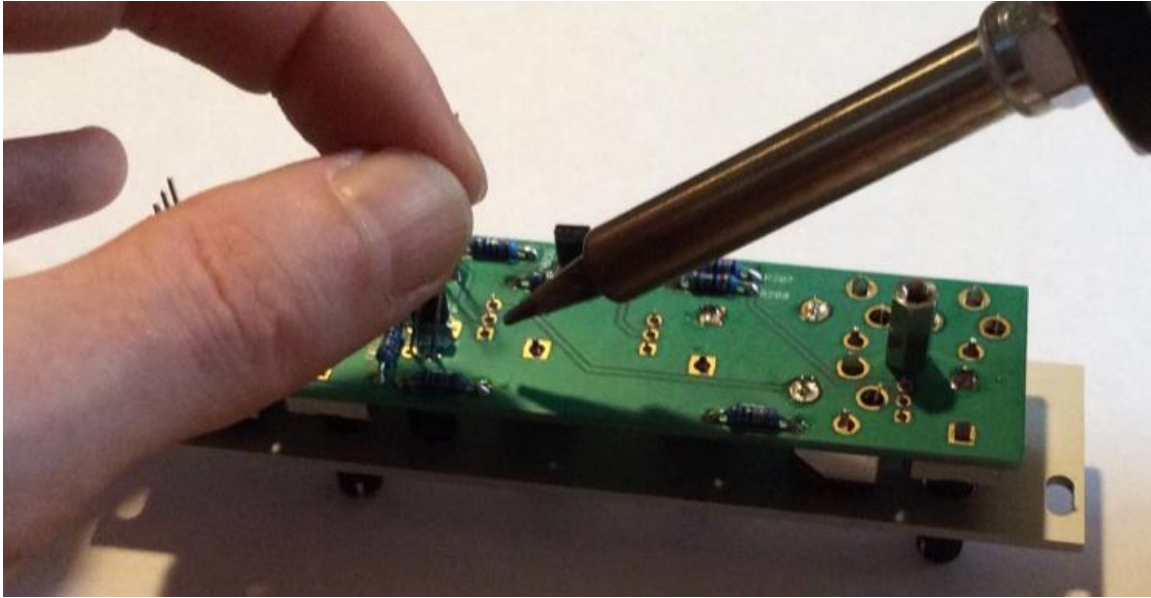

**48)** – Solder one leg of each of the LEDs, you can then reflow the solder to that pin while holding the LED legs to position it against the light pipe.



**49)** – Add the knobs then solder one of the ground tabs of each pot (including the tall trimmers). There is a little room for adjustment of the tall trimmers and pots so if they look out of alignment against the graphics or if the tall trimmers slightly rub when turn them you can reflow the solder whilst applying a little pressure to get them positioned perfectly.

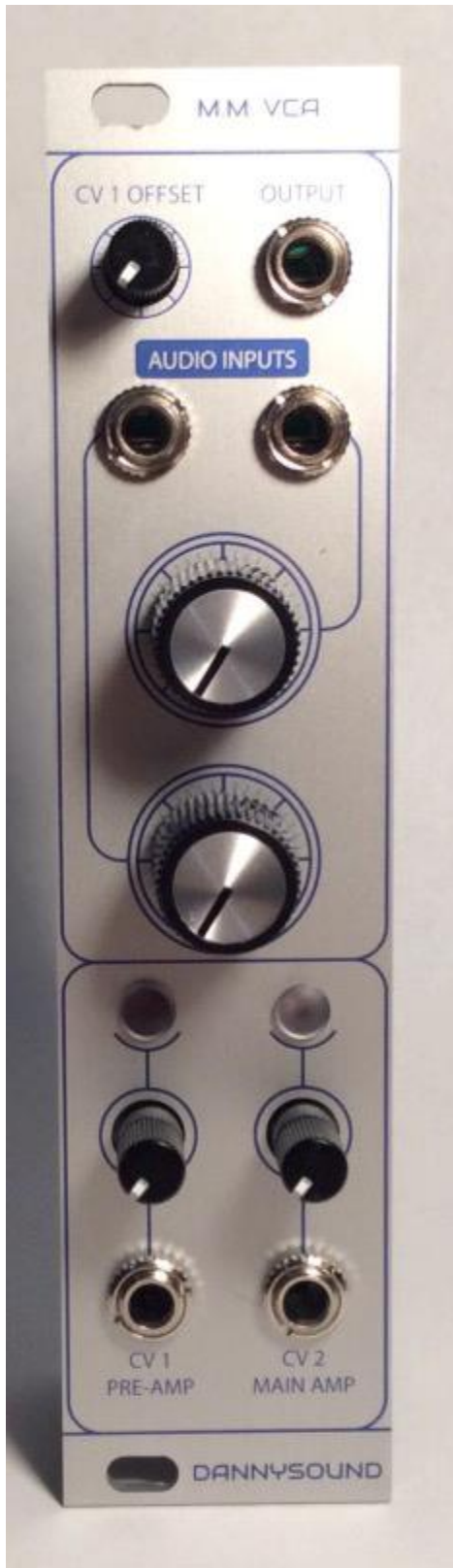

**50)** – Add the remaining nuts and then sandwich the two PCBs together and fit the remaining screws to the standoffs.



## 7 Testing and Calibration

Calibration is simple and can be done by ear or by computer oscilloscope software that allows you to see the audio waveform in realtime (WaveWindow by RustyKat for the Mac is good, PC users seem to like Soundcard Scope by Zeitnitz). You can also just do it by ear then zoom in on an audio recording on your DAW later to confirm the results. If you have a Eurorack oscilloscope module like the Mordax DATA or Jones O'Tool those can be handy too, but are really not vital at all. Calibrating these modules purely by ear will still get you very good results, it'll just take a little longer.

- 1) – Connect the output of the VCA to a mixer or an oscilloscope.
- 2) – Connect an Envelope to CV 2 MAIN AMP and set CV 2 to 100%.
- 3) – Set CV OFFSET to 100%.
- 4) – Set the envelope to produce a short pulse.
- 5) – Whilst monitoring by ear or on the scope, pulse the envelope and adjust VCA\_BALANCE2 to reduce any clicking noise.

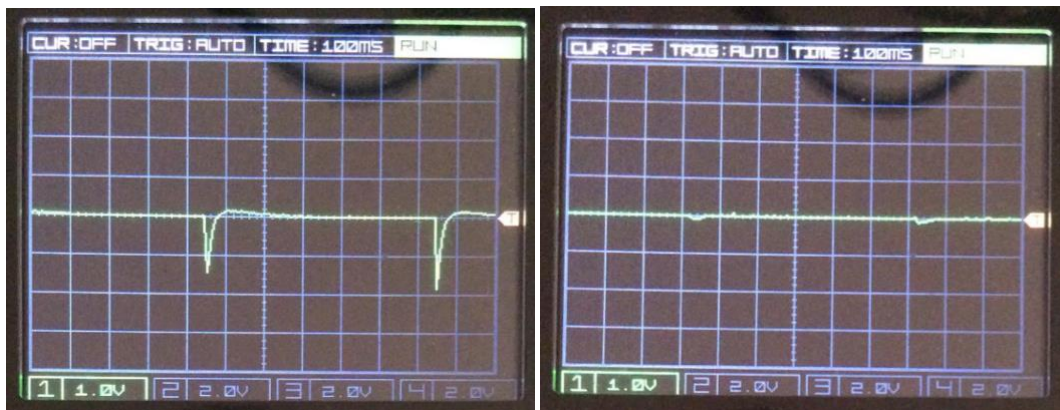

- 6) – Connect the Envelope to CV 1 PRE-AMP and set CV 1 to 100%.
- 7) – Set CV OFFSET to 0.
- 8) – Whilst monitoring by ear or on the scope, pulse the envelope and adjust VCA\_BALANCE1 to reduce any clicking noise.



- 9) – Connect the Envelope to CV 2 MAIN AMP and set CV 2 to 100%.

- 10)** – Connect an Oscillator to one of the Audio Inputs and set the volume to 50%.
- 11)** – Connect an LFO to CV 1 PRE-AMP and set CV 1 to 100%.
- 12)** – Set the CV 1 OFFSET control to 50%.
- 13)** – Set the Envelope to produce a medium Attack – Release with the Sustain set to 100%.
- 14)** – Listen to the output while firing the Envelope; you should hear the output being modulated by the LFO getting louder and back to silence with the Envelope is released.

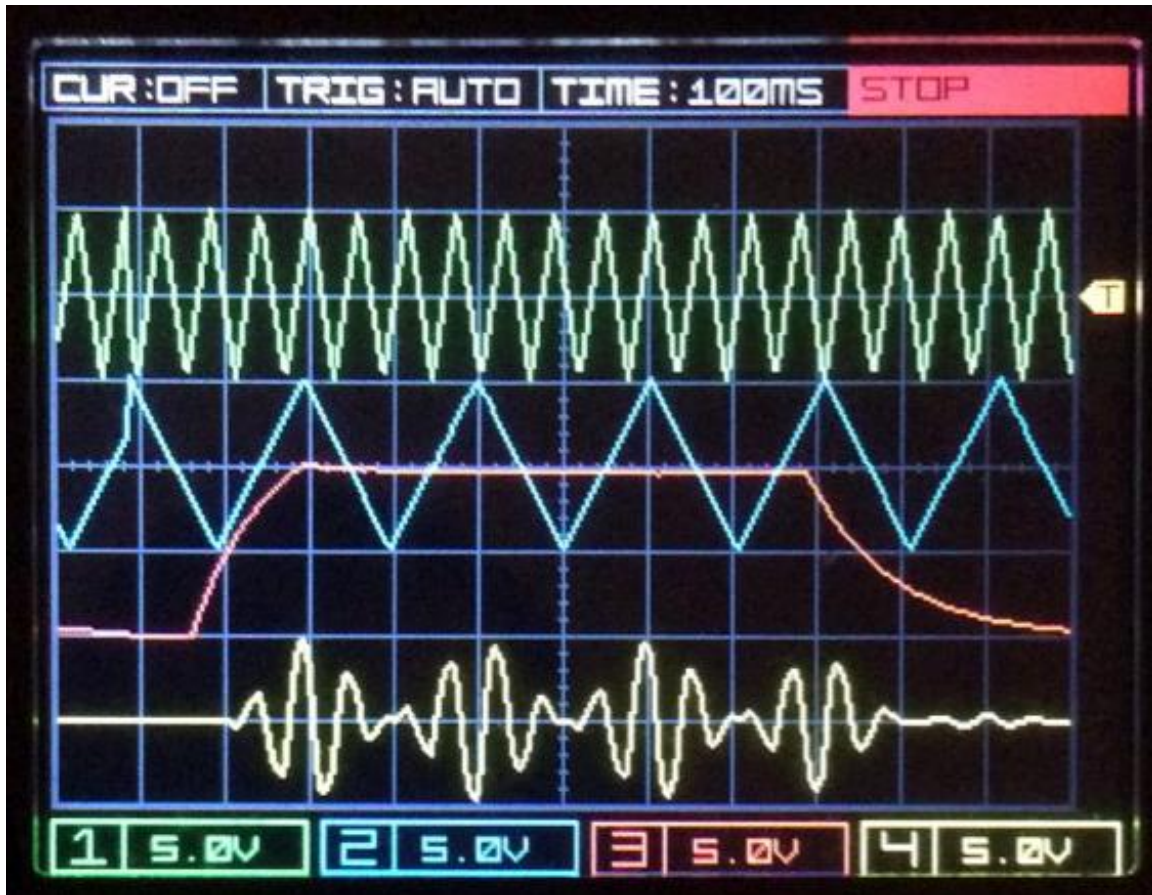

- Channel 1 (Green – Top trace) – Audio input.
- Channel 2 (Blue – Below Top Trace) – LFO connected to CV 1.
- Channel 3 (Red – Below Channel 2) – Envelope connected to CV 2.
- Channel 4 (Yellow – Lower Trace) – VCA output.

## 8 Modifications

The VCA is designed to work with Envelope Generators that produce a 10V output. For Envelopes that produce 5V output, replace R201 (Pots Board) with a wire link. You can still use 10V Envelopes with this mod if you set the CV 2 MAIN AMP input to 50%.

The same can be done with R203 for the CV 1 PRE-AMP input if so desired.

The input gain of the Audio can be increased/decreased by increasing or decreasing R104 (Outer Board). This mod is if you require more or less clipping. Values in the range of 68k to 150k should be suitable, although these are untested.

R107 (Outer Board), sets the overall output volume. The value is 100k, which can be thought of as 100% and then adjusted accordingly for more or less gain.