

本公司智慧財產，未經同意不得複製
DAILYWELL copyright, may not be used
without permission from DAILYWELL

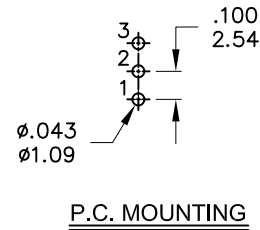
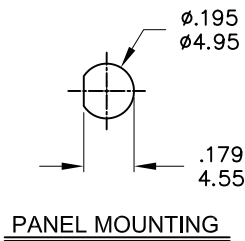
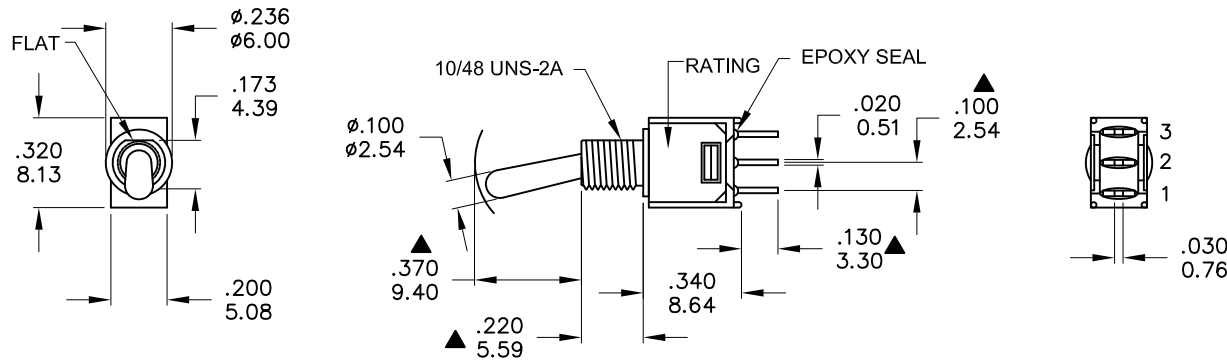

Model No.	POS.1	POS.2	POS.3
2MS3	ON	OFF	ON
Term. Comm.	2-3	OPEN	2-1
SCHEMATIC			

SWITCH FUNCTION

	PART NO.	PART NAME	Q'TY
1	MNU-2M01	10-48 INCH NUTS	2
2	MNU-2M03	LOCKING WASHER	1

FILE NAME:HARDWARE-0003

SPECIFICATIONS

MECHANICAL LIFE: 30,000 make-and-break cycles.
CONTACT RESISTANCE: 20mΩ max. initial @ 2-4VDC
 100mA for both silver and gold plated contacts.
INSULATION RESISTANCE: 1,000MΩ min.
DIELECTRIC STRENGTH: 1,000 V RMS@sea level.
OPERATING TEMPERATURE: -30°C to 85°C.

MATERIALS

CASE - Diallyl phthalate(DAP)(UL94V-0)
ACTUATOR - Brass,chrome plated
BUSHING - Brass,nickel plated
HOUSING - Stainless Steel
SWITCH SUPPORT - Brass,tin plated.
TERMINALS/CONTACT - Brass, with Silver or gold plated.
 RoHS - 2002/95/EC

	CONTACT MATERIAL	TERMINAL PLATING	RATINGS
Q	Silver	Q = Silver	3 Amps @120 VAC or 28 VDC 1 Amps @250VAC
S		S = Silver,pure-tin	
C	Gold over Silver	C = Gold over silver	
K		K = Gold over silver,pure-tin	
R	Gold	R = Gold	0.4 Volt-Amps(VA) max. @20V max. (AC or DC)
G		G = Gold,pure-tin	

德利威電子股份有限公司
DAILYWELL ELECTRONICS CO.,LTD.

	符號	原尺寸	修改後尺寸	變更日期	SCALE (比例): 3:2	TITLE 圖名	Sub - Miniature Toggle Switches	SIZE 圖紙	A4		
1	Ⓐ				TOLERANCE (公差): 0.00 mm ± 0.25mm 0.0 mm ± 0.40mm ANGULAR : ± 5° FILE NAME : 2MSP0654	DWG NO. 圖號	2MS3T1B1M2QES-5	UNIT 單位	inch mm		
2	Ⓑ					REV. 版本	A	DATE 日期	JAN - 26 - 2010	SHEET 張數	1 of 1
3	Ⓒ					CHECKED BY 審核	RICHARD		DRAWN BY 製圖	IRENE	
4	Ⓓ										
5	Ⓔ										

本公司智慧財產，未經同意不得複製
DAILYWELL copyright, may not be used
without permission from DAILYWELL

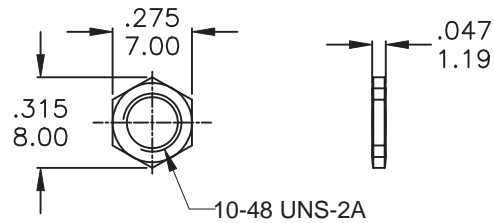

Ⓐ MNU-2M01

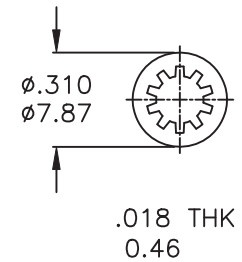

MNU-2M03

	PART NO.	PART NAME	Q'TY
1	MNU-2M01	10-48 INCH NUTS	2
2	MNU-2M03	LOCKING WASHER	1



德利威電子股份有限公司
DAILYWELL ELECTRONICS CO.,LTD.

符號	原尺寸	修改後尺寸	變更日期	SCALE (比例) : 3 : 2	TITLE 圖名	HARDWARE		SIZE 圖紙	A4	
1	Ⓐ	修正NU-2M01物料尺寸參照NU-2M01(C)	JAN-07-2013	TOLERANCE (公差) : 0.00 mm ± 0.25mm 0.0 mm ± 0.40mm ANGULAR : ± 5° FILE NAME : HARDWARE-0003	DWG NO. 圖號	10-48 IN BUSHING PART		UNIT 單位	inch mm	
2	Ⓑ				REV. 版本	B	DATE 日期	DEC - 27 - 2007	SHEET 張數	1 of 1
3	Ⓒ				CHECKED BY 審核	RICHARD		DRAWN BY 製圖	FION	
4	Ⓓ									
5	Ⓔ									