

CIRCUIT

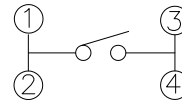

REV	DESCRIPTION	DRW	DATE
A	NEW	X X S	

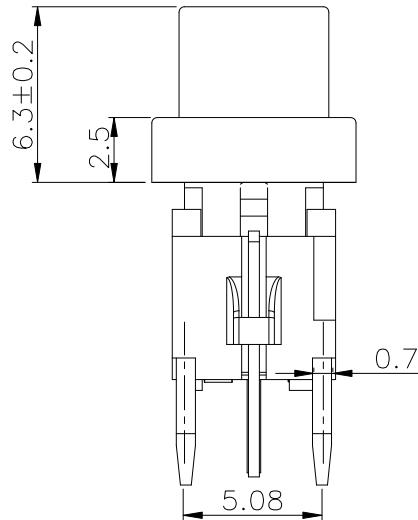
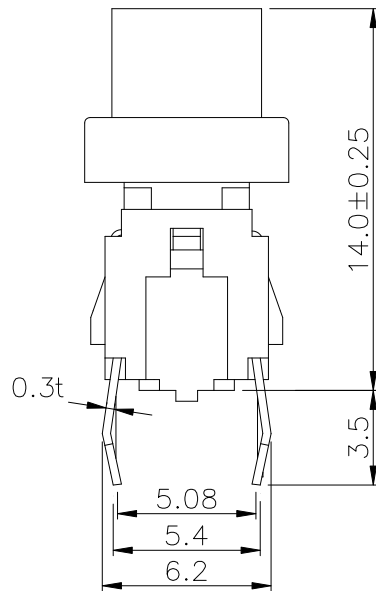
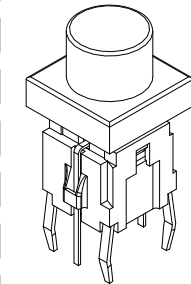

NOTES:

- 1.RATING: 12VDC 50mA
- 2.CONTACT RESISTANCE: 100mΩ Max
- 3.INSULATION RESISTANCE: 100MΩ 250VDC FOR 1MIN
- 4.DIELECTRIC STRENGTH: 250VAC(50/60Hz) FOR 1MIN
- 5.LIFE TEST:100,000 CYCLES
- 6.OPERATION FORCE&TRAVEL: SEE SPECIFICATION

P.C.B LAYOUT

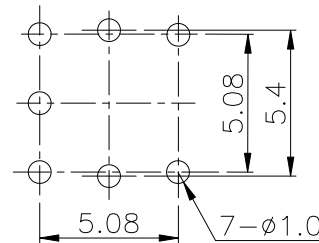

6	COVER	ABS
5	TERMINAL	Bronze Silver Plated
4	CONTACT	SUS
3	LED	GaAsP/GaP
2	BUTTON	
1	HOUSING	PA66
ITEM	PART NAME	MATERIAL

TOLERANCE UNLESS OTHERWISE STATED				DRAWN	DATE	TITLE	TACT SWITCH	
X.X	±0.25	∠	±0.5'	CHK'D	DATE	MODEL		
X.XX	±0.1	UNIT	mm	APPV'D	DATE	MATL		
REV	A	SCALE	4:1			FINISH		
SIZE	A4	SHEET	1 OF 1					