



OVERVIEW

For the most recent version of this document please visit

<http://www.thonk.co.uk/documents/alm/sid>

For all technical support please visit <http://bit.ly/1fYBjy> on Muffwiggler.

The SID GUTS manual is here, please read:

<http://busycircuits.com/docs/alm003-manual.pdf>

NOTE: Part of the build process is documented in a video on Vimeo.com, if you're going to be working offline then it's suggested you <http://bit.ly/1iGOhwi> instead.



All Thonk kits are sold under our standard Terms and Conditions - <http://www.thonk.co.uk/faq/>

DIY INSTRUCTIONS

This document gives detailed instructions that assume you have purchased a complete kit from www.thonk.co.uk. It also assumes no previous knowledge of electronics. To learn to solder try http://youtu.be/I_NU2ruzyc4 and the **Adafruit guide to excellent soldering** - <http://bit.ly/1177tF4>

Watch and understand that whole YouTube video! If you're not achieving the results shown in the video then you need to buy new tools or seek advice.

You will not end up with a working module otherwise.

TOOLS REQUIRED

Soldering iron, snipe nose pliers, wire strippers, small flat head screwdriver and diagonal cutters AKA snips AKA side-cutters. A Digital Multimeter is useful for calibrating this module but you can do it by ear to taste. Thonk sell a range of inexpensive tools here - <http://bit.ly/1jxqF3n>



SOLDER JOINTS

Your solder joints should look like those shown as 'OK' below, they should have that neat conical shape on **BOTH sides of the PCB**. If they don't look the same on both sides then stop! Work out why from the soldering guides linked and don't continue until you are getting those results.

This isn't just OCD talking, you are very likely to end up with a destroyed, damaged or defective unit if you're not hitting that standard.

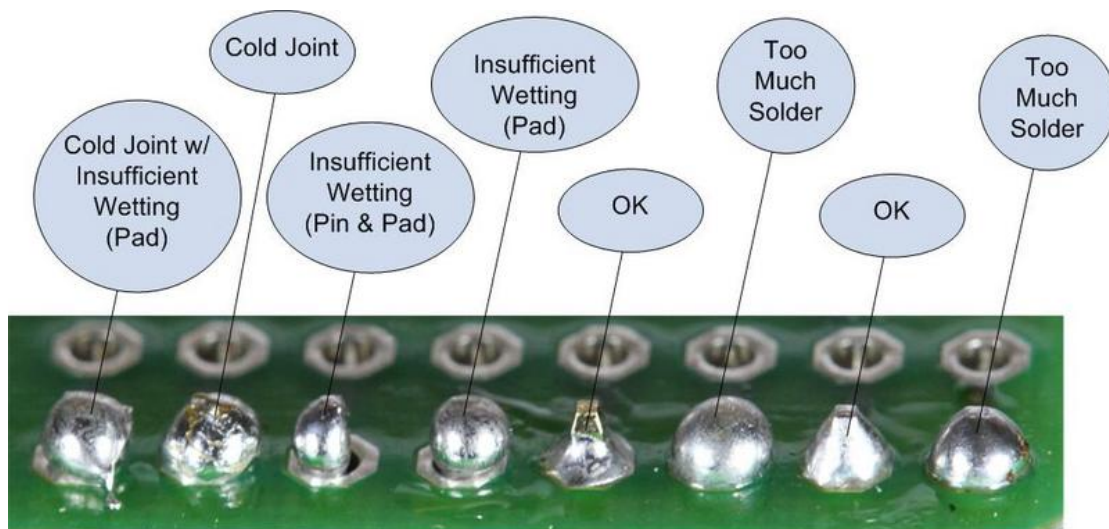

This photo is from the **Adafruit guide to excellent soldering** - <http://bit.ly/1jxqF3n> and is reproduced under an Attribution-Sharealike creative commons license - <http://creativecommons.org/licenses/by-sa/3.0/>



ALM SID GUTS DIY BUILD INSTRUCTIONS

1.

Start by emptying **BAG A** into a bowl or container. This makes it much easier to pick parts as you need them and you're less likely to lose anything.

2.

Note the identification of the LOGIC BOARD PCB and CONTROL BOARD PCB as shown.

For efficiency we'll be soldering both boards at once. This way you are much less likely to end up with loose resistors that you have to hunt down homes for.

Note that yellow PCBs were distributed with kits and blue PCBs were distributed for sale loose.

The green boards are the same, with some minor silkscreen differences that will be identified if necessary.

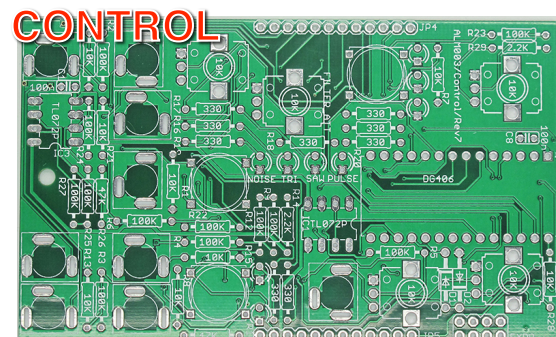
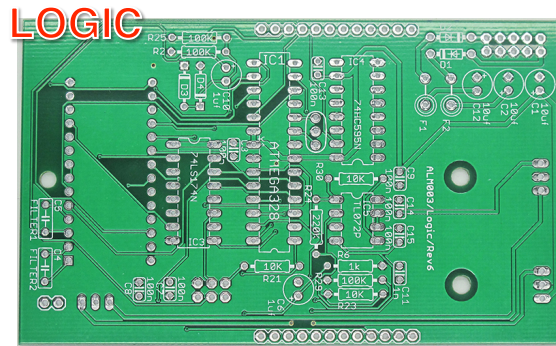

3.

LOGIC BOARD: Solder three 10k resistors into positions R21, R23, R30

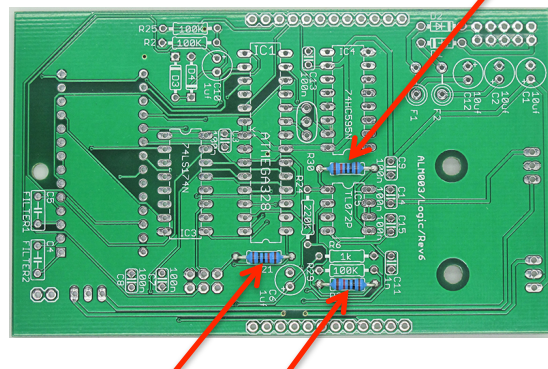



4.

CONTROL BOARD: Solder the remaining eight 10k resistors into positions R1, R7, R8, R11, R13, R15, R21, R28

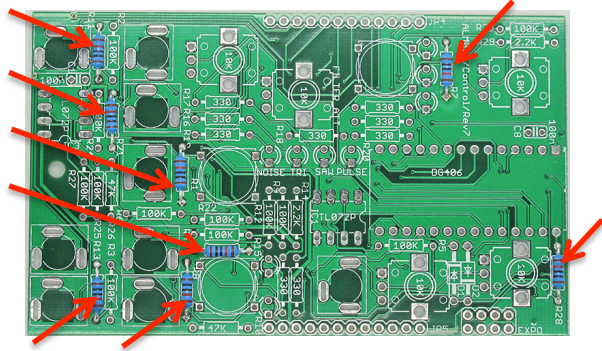

5.

LOGIC BOARD: Solder the three 100k resistors into positions R2, R25, R29

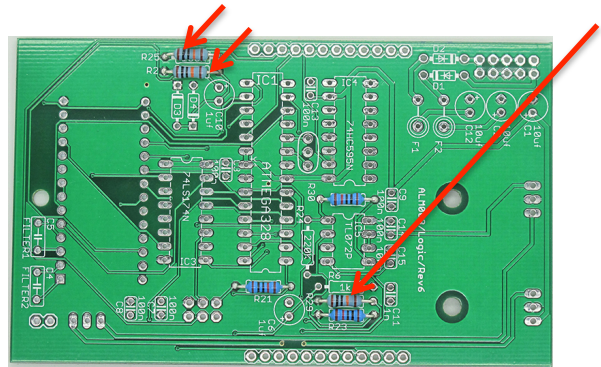

6.

CONTROL BOARD: Solder the twelve remaining 100k resistors into positions R2, R3, R4, R5, R6, R9, R12, R22, R23, R24, R25, R27

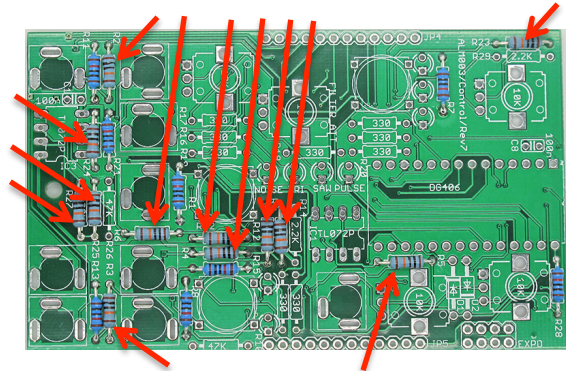

7.

LOGIC BOARD: Solder the single 1k resistor into position R6

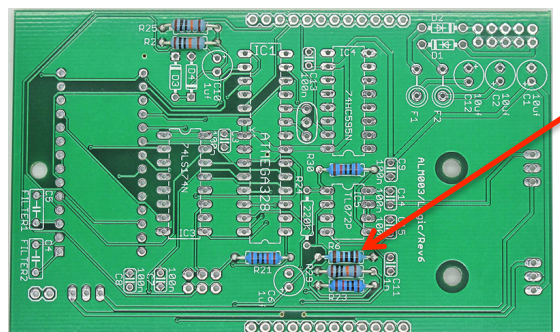



8.

CONTROL BOARD: Solder the single remaining 1k resistor into position R30

NOTE: This resistor isn't on the earlier green revision of the board, but is on all blue and yellow PCB boards sold through Thonk.

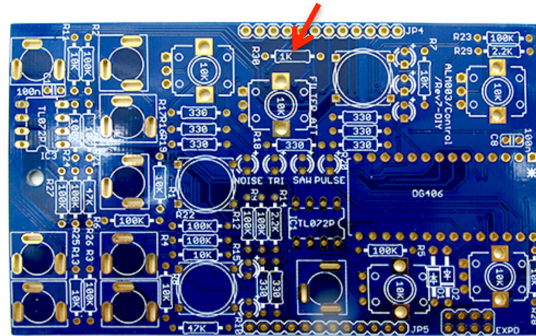

9.

CONTROL BOARD: Solder the two 47k resistors into positions R10, R26

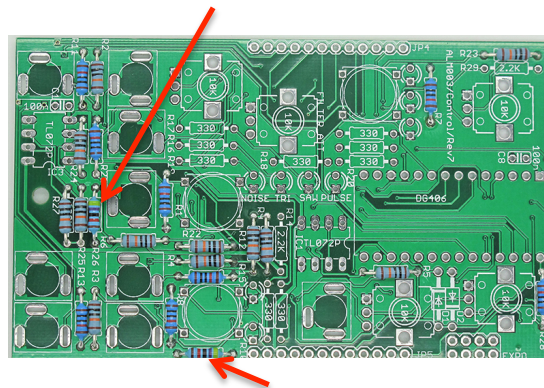

10.

CONTROL BOARD: Solder the nine 330R resistors into positions *LED_LO*, *LED_LO1*, *LED_MID*, *LED_MID1*, R16, R17, R18, R19, R20

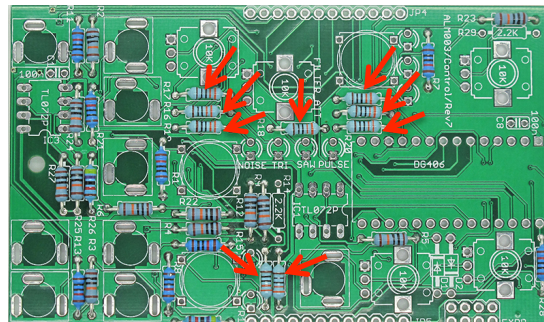

11.

CONTROL BOARD: Solder the two 2.2K resistors into positions R14, R29

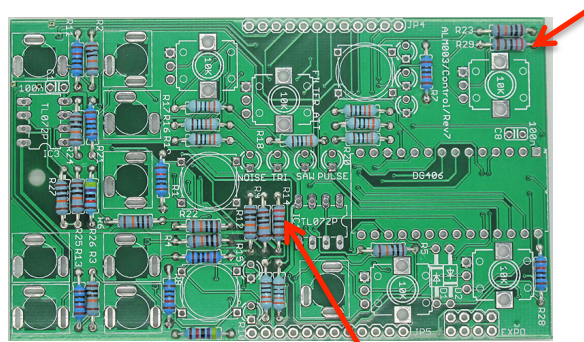



12.

LOGIC BOARD: Solder the single 220K resistor into position R24

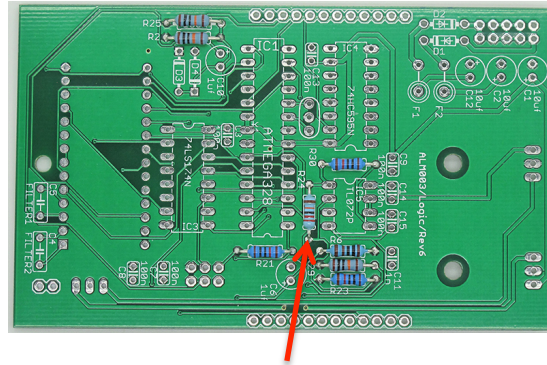

13.

LOGIC BOARD: Solder the two black and silver Schottky Barrier Diodes into positions D1 and D2.

NOTE: Orientation is vital. The silver band on the diode should match the white band on the silkscreen. **Diodes can be damaged by overheating.**

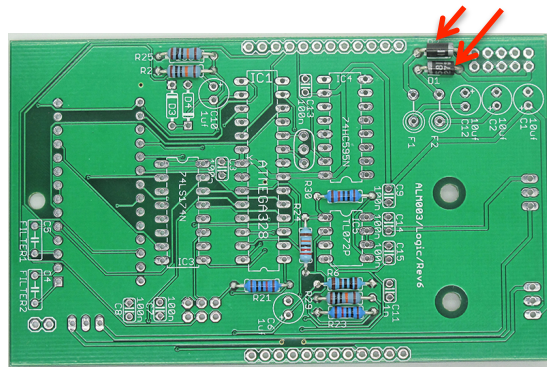

14.

LOGIC BOARD: Solder the two orange 1N4148 Diodes into positions D3 and D4

NOTE: Orientation is vital. The black band on the diode should match the white band on the silkscreen. **Diodes can be damaged by overheating.**

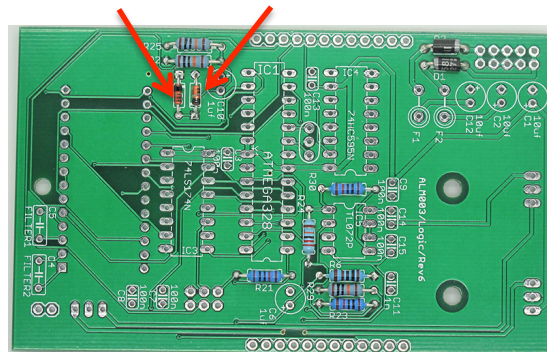

15.

CONTROL BOARD: Solder the two orange BAT85 Diodes into positions D1 and D2

NOTE: Orientation is vital. The black band on the diode should match the white band on the silkscreen. **Diodes can be damaged by overheating.**

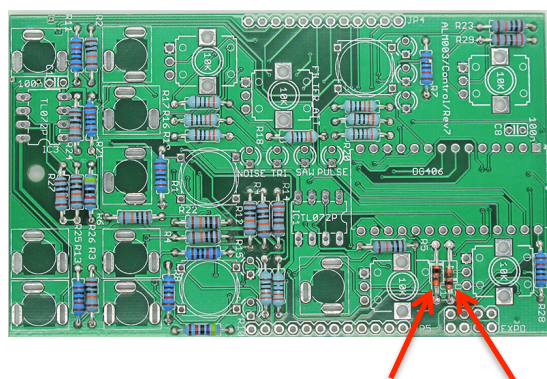



16.

LOGIC BOARD: Solder the single 1n Capacitor into position C11

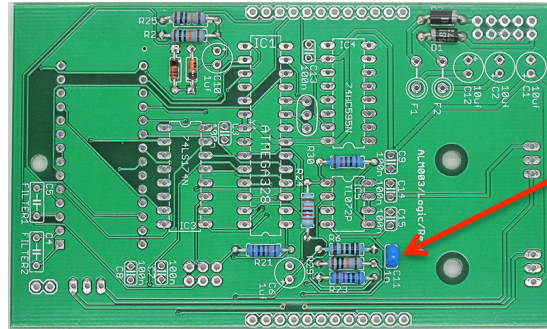

17.

LOGIC BOARD: Solder the seven 100n Capacitors into the positions shown.

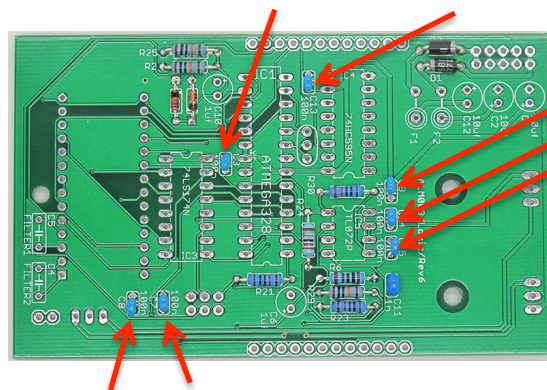

18.

CONTROL BOARD: Solder the two remaining 100n Capacitors

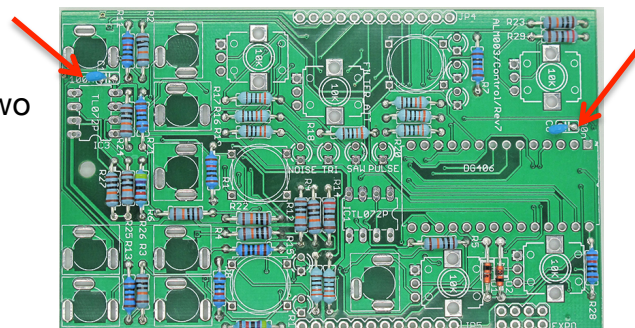

19.

LOGIC BOARD: Solder the four IC sockets from **BAG B** as shown. NOTE in the full kit the ATMEGA IC socket will be a single 28 pin socket.

NOTE: Take care to orient the notches in the end of the sockets so they match the notch on the silkscreen.

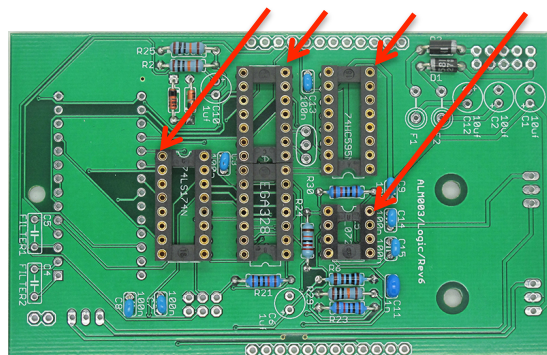



20.

LOGIC BOARD: Solder the three 10uF electro caps into positions C1, C2, and C12

NOTE: Orientation is vital! The longer lead of the capacitor should go into the hole marked with the + symbol.

NOTE: The blue/grey stripe on the body of the capacitor shows the negative side of the capacitor

NOTE: C12 is not positioned in the same orientation as C1 and C2. It's reversed relative to those.

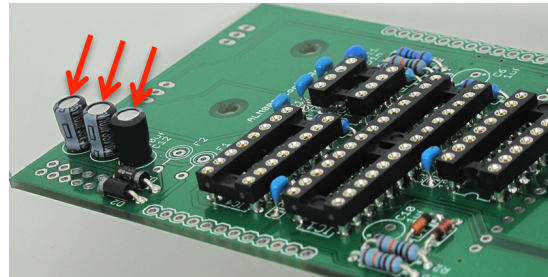

21.

LOGIC BOARD: Solder the two 1uF electro caps into the positions C6 and C10.

NOTE: Orientation is vital! The longer lead of the capacitor should go into the hole marked with the + symbol.

NOTE: The blue/grey stripe on the body of the capacitor shows the negative side of the capacitor

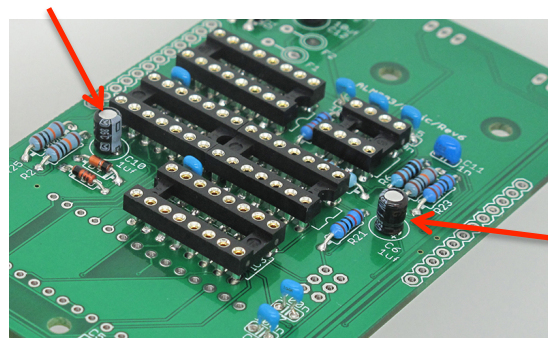

22.

LOGIC BOARD: Solder the four six-pin female headers into the positions shown.

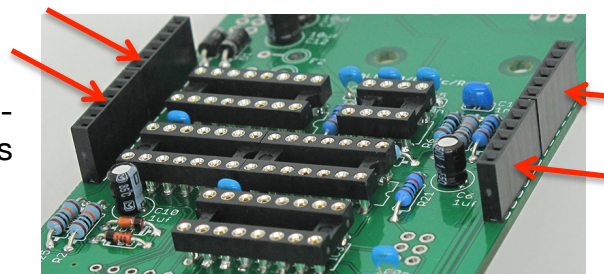



23.

LOGIC BOARD: Solder the orange resonator into the position shown. The orientation is not important, it can go either way.

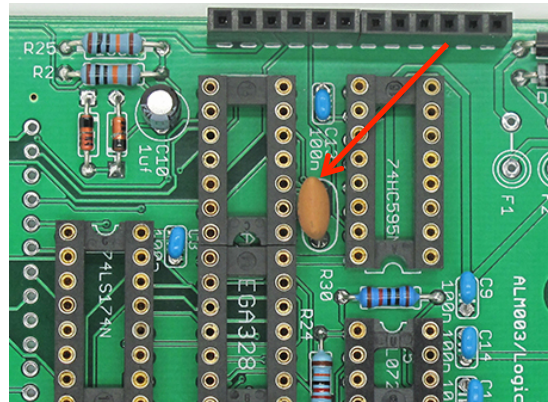

24.

Solder the two ferrite beads into positions F1 and F2 as shown. The orientation is not important, they can go either way.

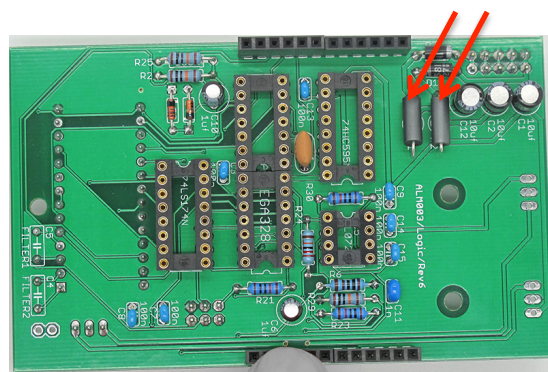

25.

LOGIC BOARD: Flip the board and solder the large 28 pin IC socket.

NOTE: Take care to orient the notch in the end of the socket so it matches the notch on the silkscreen.

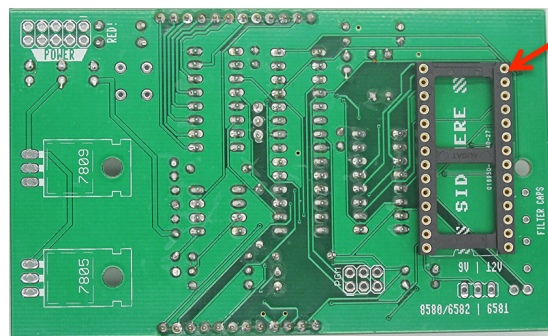

26.

Next take the two single row three pin sockets and cut the middle pin as shown.

You don't need to cut so close to the black plastic body if you don't have suitable tools, just cut the thin lead below the thicker cylindrical section.

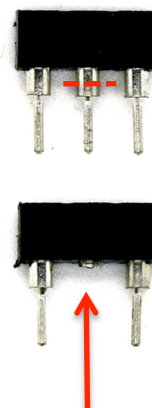



27.

LOGIC BOARD: Solder the modified SIL sockets into position.

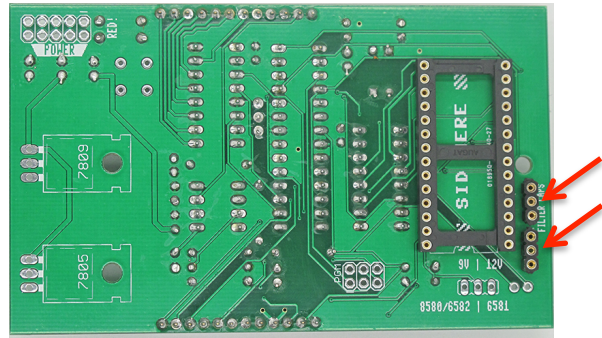

28.

LOGIC BOARD: Solder these three pin headers into place.

- 2x5 pin – Power header
- 2x3 pin – PGM header (optional)
- 1x3 pin – SID voltage selector

NOTE: You have a single long pin header that you need to cut down to create the 1x3 pin header for SID voltage selection.

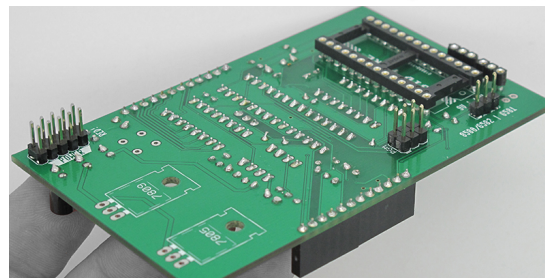
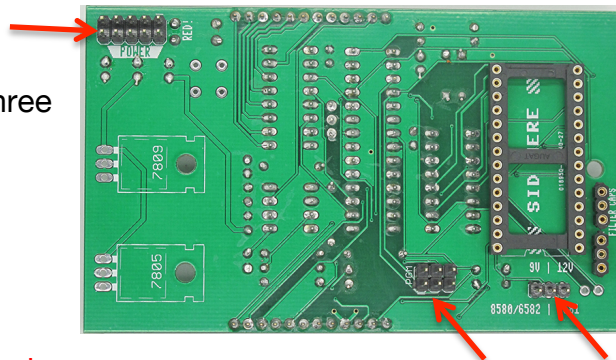

NOTE: You only need the PGM header if you foresee needing to reprogram the ATMEGA firmware chip. The software is in a very stable state after having already shipped in a retail run. If software fixes are available in the future there will most likely be an option to purchase a pre-programmed chip from Think or ALM.



29.

Take the 7805 voltage regulator from the pink ESD proof packet with yellow warning sticker.

DO NOT SOLDER but bend the pins as shown so the regulator fits as shown. **Orientation is vital on this part.**

Remove the regulator again.

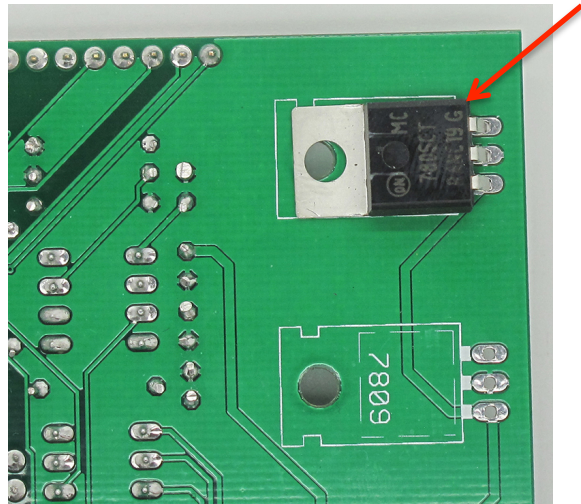
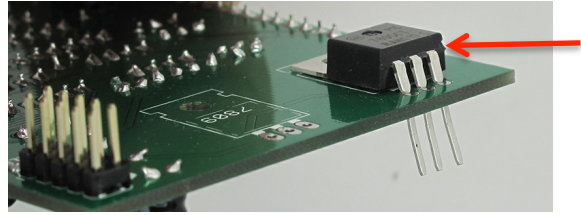

30.

Insert the regulator into the heat sink as show. It will clip firmly into place.

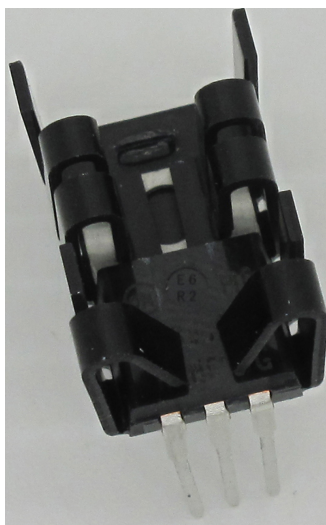
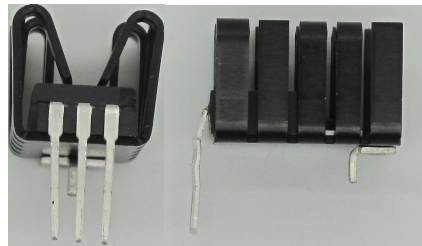



31.

Solder the three pins on the heatsink fitted 7805 regular as shown. It's good for the heatsink to sit at an angle away from the PCB, it shouldn't sit completely flush and parallel as it reduces heat dissipation.

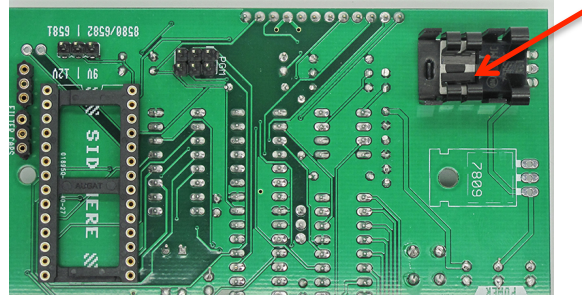

IF YOU GET THE 7805 AND 7809 THE WRONG WAY ROUND YOU ARE LIKELY TO DESTROY ALL IC'S ON POWER UP!

32.

Repeat steps 29-31 for the 7809 regulator.

IF YOU GET THE 7805 AND 7809 THE WRONG WAY ROUND YOU ARE LIKELY TO DESTROY ALL IC'S ON POWER UP!

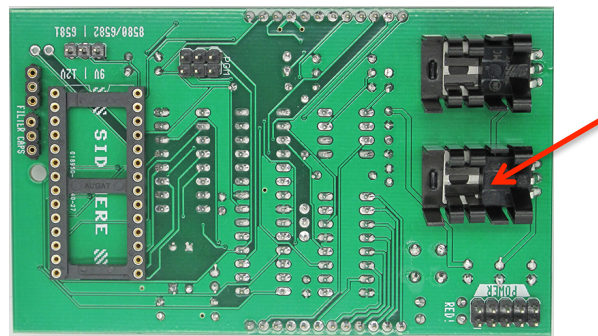

33.

CONTROL BOARD: Solder the three IC Sockets as shown.

NOTE: Take care to orient the notches in the end of the sockets so they match the notch on the silkscreen.

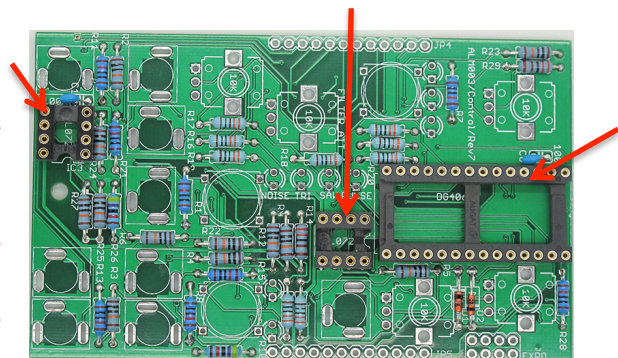



34.

Put the pots switches, jacks and LEDs into position but **DO NOT SOLDER**.

Note the orientation of the blue switches, make sure they are sitting flush to the surface of the PCB.

The longer lead of each LED should go into the hole marked with a +.

DO NOT SOLDER yet

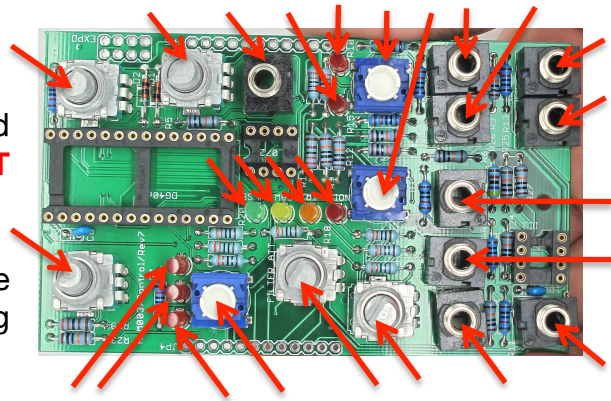

35.

Put the switch caps onto the switches, align the grooves so they fit right down onto the switch as shown.

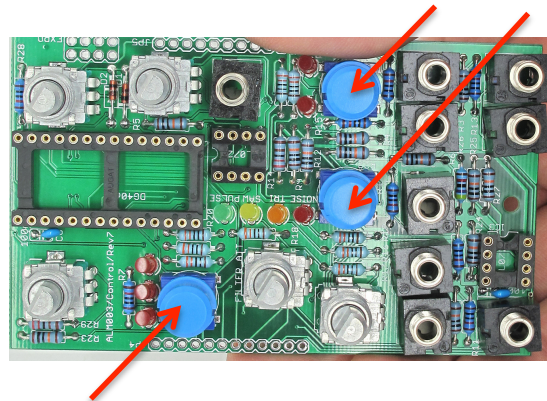
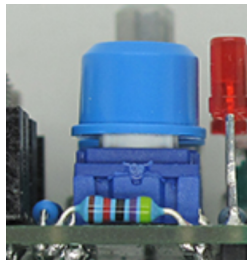

DO NOT SOLDER yet



36.

Put the faceplate carefully onto the PCB so that all the pots, switches, LEDs and jacks are poking through and sitting flush.

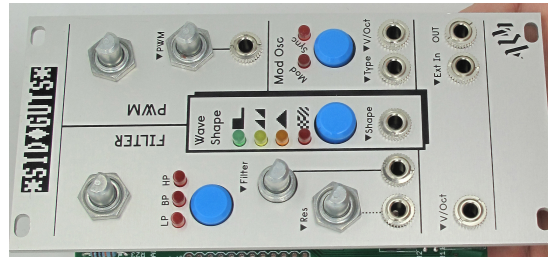

Hand tighten all the nuts and make sure the switches are sitting square and that the switch caps are not rubbing against the panel.

Now solder all the pots, jacks, switches and LEDs.

Double check each LED is protruding through the panel before soldering.

Remove the panel again. **Double/Triple check that you didn't miss any solder joints!**

37.

Cut the remaining single row pin header down into two 12 pins strips and solder into place as shown.

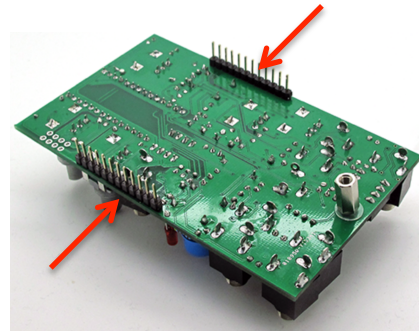

38.

Next all the IC's need to be inserted **EXCEPT** the SID or SwinSID.

LOGIC BOARD: Insert the ATMEGA, 74LS174N, 74HC595N, and one of the three TL072's.

NOTE: The * signs on the image which denote the 'notch' end of the IC (the location of pin 1). Orientation is vital.

REMEMBER; DO NOT INSERT SID CHIP OR SwinSID YET.

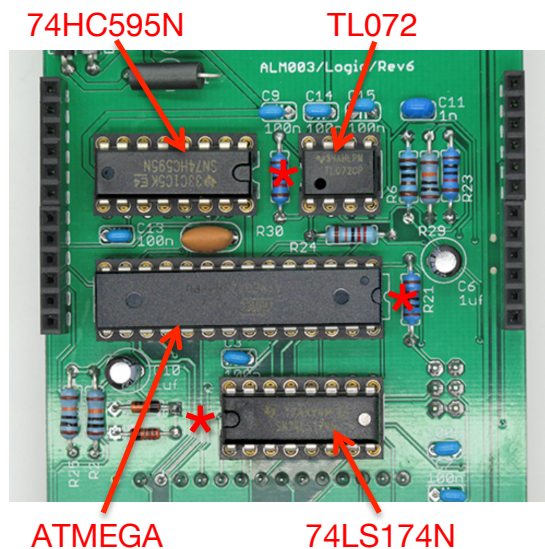

The ATMEGA chip comes pre-programmed with the SID GUTS firmware.



39.

CONTROL BOARD: Insert the DG406 and the two remaining TL072 chips.

NOTE: The * signs on the image which denote the 'notch' end of the IC (the location of pin 1). Orientation is vital.

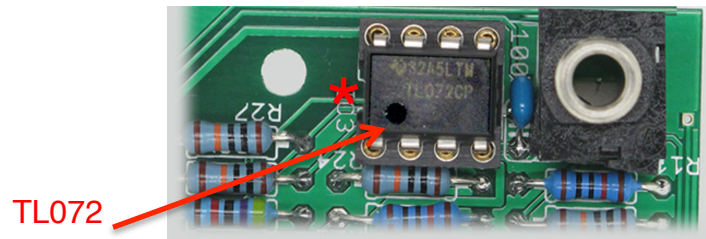
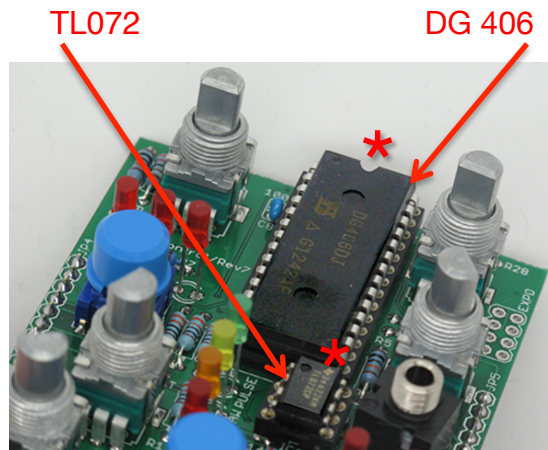

40.

The two PCBs can now be joined together

Use the two machine screws, four plastic washers and metal hex post to secure them. Do not over-tighten the machine screws.

Ensure that there is a plastic washer on each of the four exposed faces of the PCB.

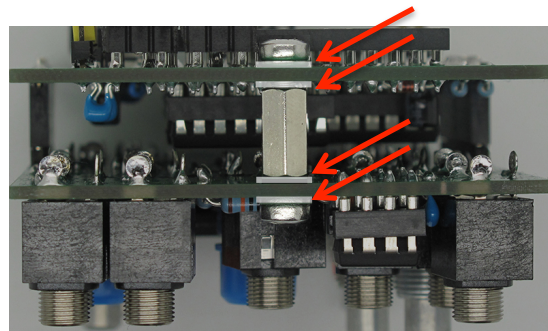
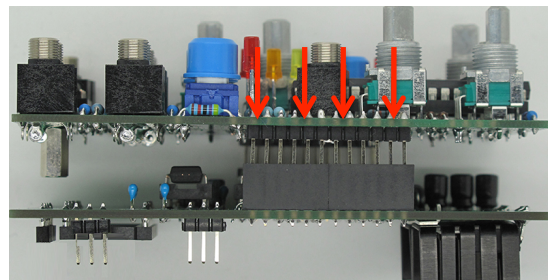



41.

Next the power cable should be attached for the testing phase that is necessary before inserting the SID.

NOTE: Red stripe down, where it says RED! on the PCB.

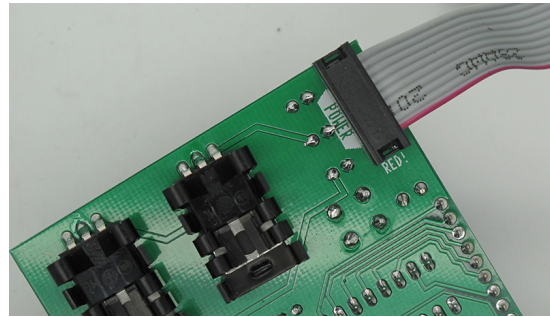

42.

Next watch the video explanation on VIMEO of how to do the power-up test prior to inserting the SID chip - <http://vimeo.com/90017525>

Alternatively, you can download the video [here](http://bit.ly/1iGOhwi) instead - <http://bit.ly/1iGOhwi>



NOTE: DO NOT SKIP THIS STAGE.

43.

If the test went well then it's time to insert the SID chip, the Filter caps and the voltage header.

NOTE: The * sign on the image which denotes the 'notch' end of the IC (the location of pin 1). **Orientation is vital.**

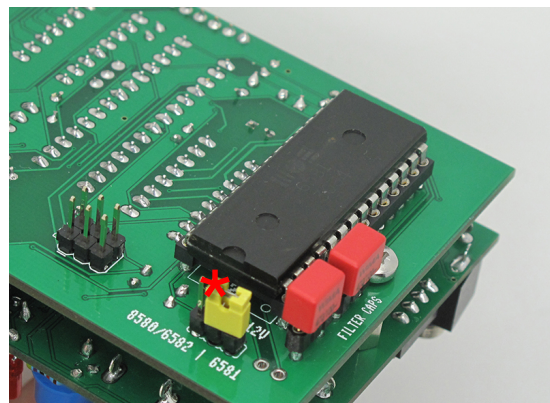

NOTE: Genuine SID chips are easily damaged or destroyed through incorrect handling. ESD handling precautions should be observed and care should be taken to not dislodge the SID chip once power is on, or accidentally bridge pins with your fingers or tools.



44.

Finally we install the filter caps and the power jumper.

The SID GUTS supports 3 different types of SID chip; The original 6581 chip, the later 8580 and a modern hardware emulation chip - the 'SwinSID'. The SID chip should be clearly identified. Beware of fake SID chips or partly working SID chips with broken filters.

- **For a 6581 chip**, the jumper should be set accordingly for 12V. The capacitors should be 470PF (supplied).
- **For a 8580 chip**, the jumper should set accordingly for 9V, the capacitors should be 2.2NF (supplied)
- **For a SwinSID3 or Nano SwinSID**, the jumper can be removed, as can the capacitors - they have no effect on the filter.

EXAMPLE - 6581 chip

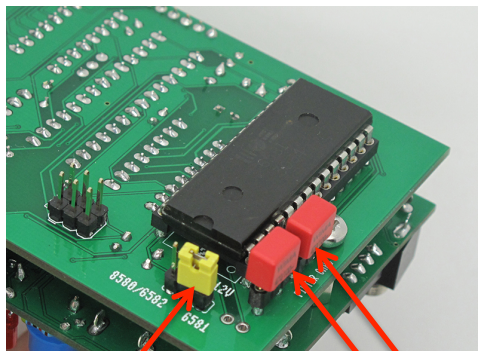

Jumper set to 12v

470pF Filter
Caps

EXAMPLE – Nano SwinSID chip

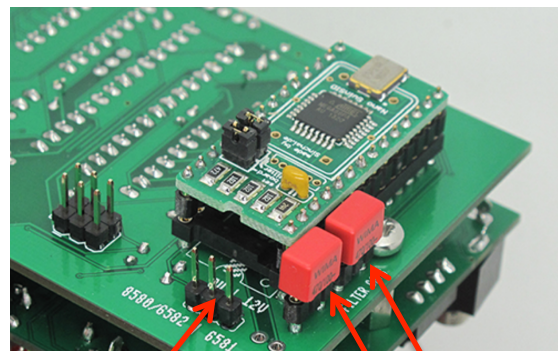

Jumper not required
but can be present

Filter caps not
required but
can be present

You are now finished and ready to power up the module.

Remember to take care with the power cable orientation!

For the most recent version of this document please visit
<http://www.thonk.co.uk/documents/alm/sid>

For all technical support please visit <http://bit.ly/1fYBjyy> on Muffwiggler.

The SID GUTS manual is here, please read:

<http://busycircuits.com/docs/alm003-manual.pdf>