

Dannysound Cali Oscillator

Build Guide

Contents

Section 1 - Main PCB

Resistors

Diodes

Inductors

IC Sockets

Capacitors

Transistors

Power Socket

Trim Pots

Electrolytic Capacitors

Board Connector

Section 2 – Power Test, Matched Transistors and IC placement

Section 3 – Pots PCB

Resistors

IC Sockets

Capacitors

Trim Pot

Transistors

Panel Components

Section 4 – Calibration

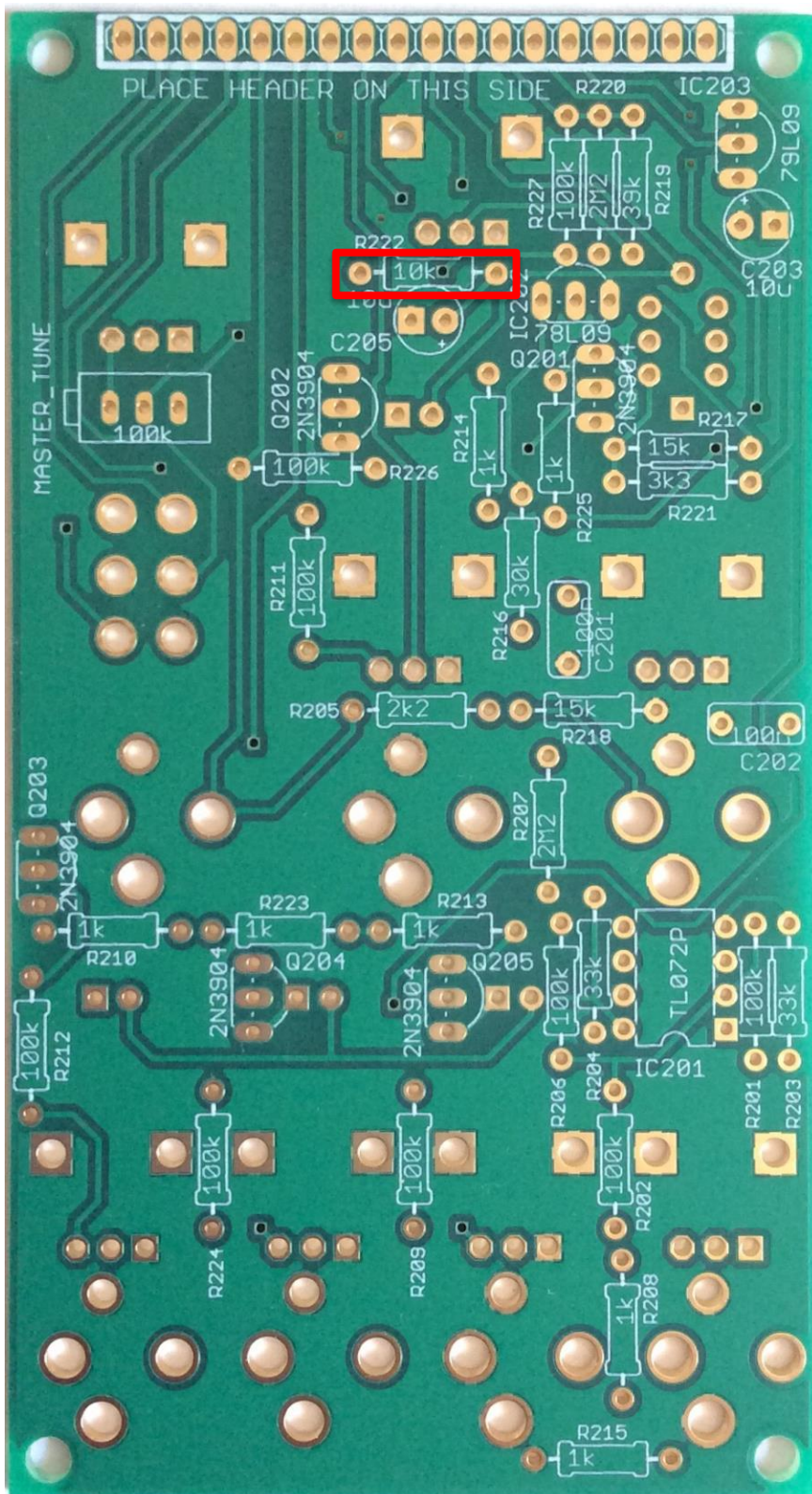

1 – Before starting on the main PCB, first locate the single 5.6K resistor and solder into R222. Note: The PCB has the wrong value printed – 5.6K is correct.

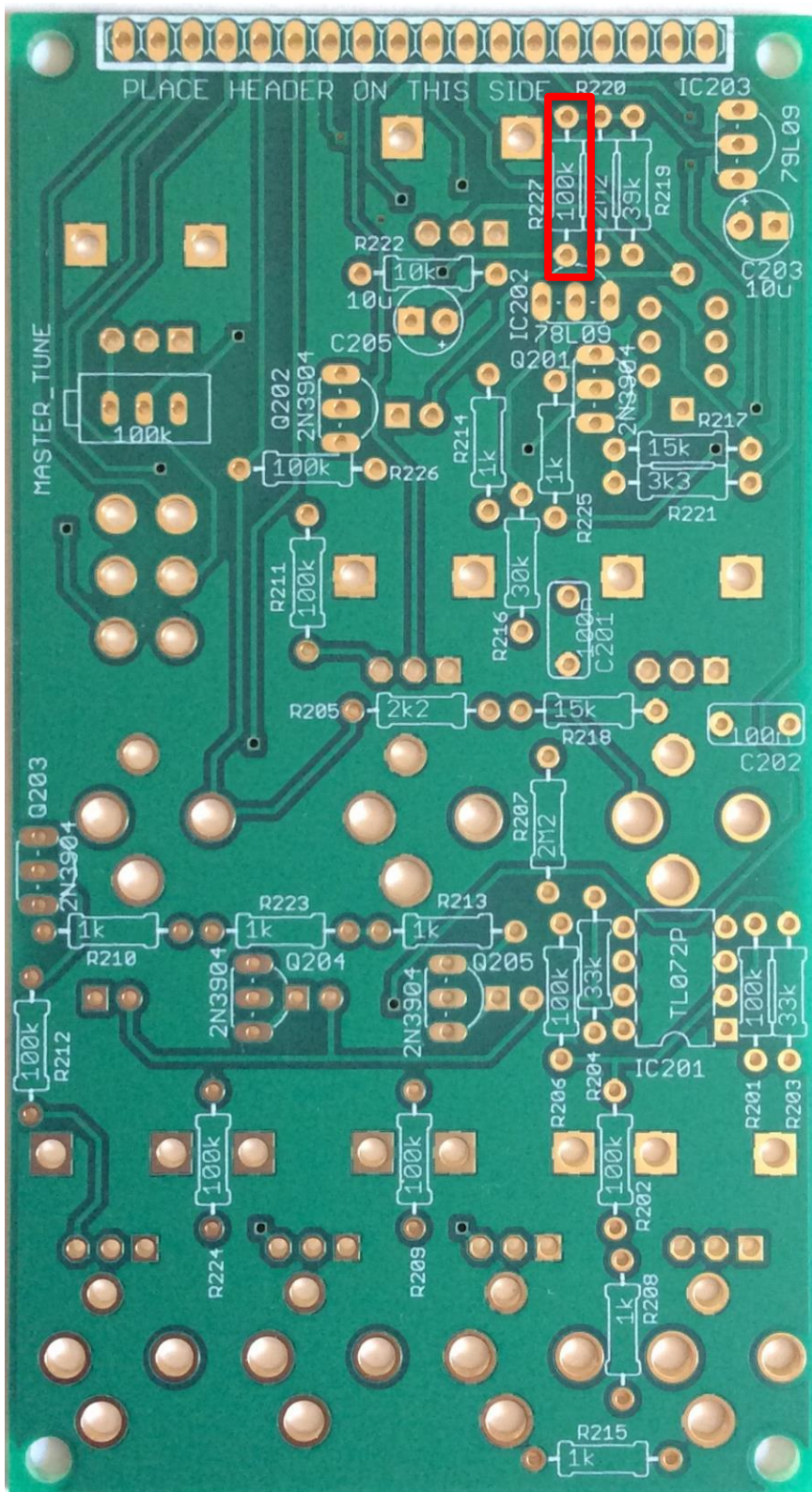

2 – Then locate the single 39K resistor and solder into R227. Note: The PCB has the wrong value printed – 39K is correct.

Section 1 - Main PCB

Resistors

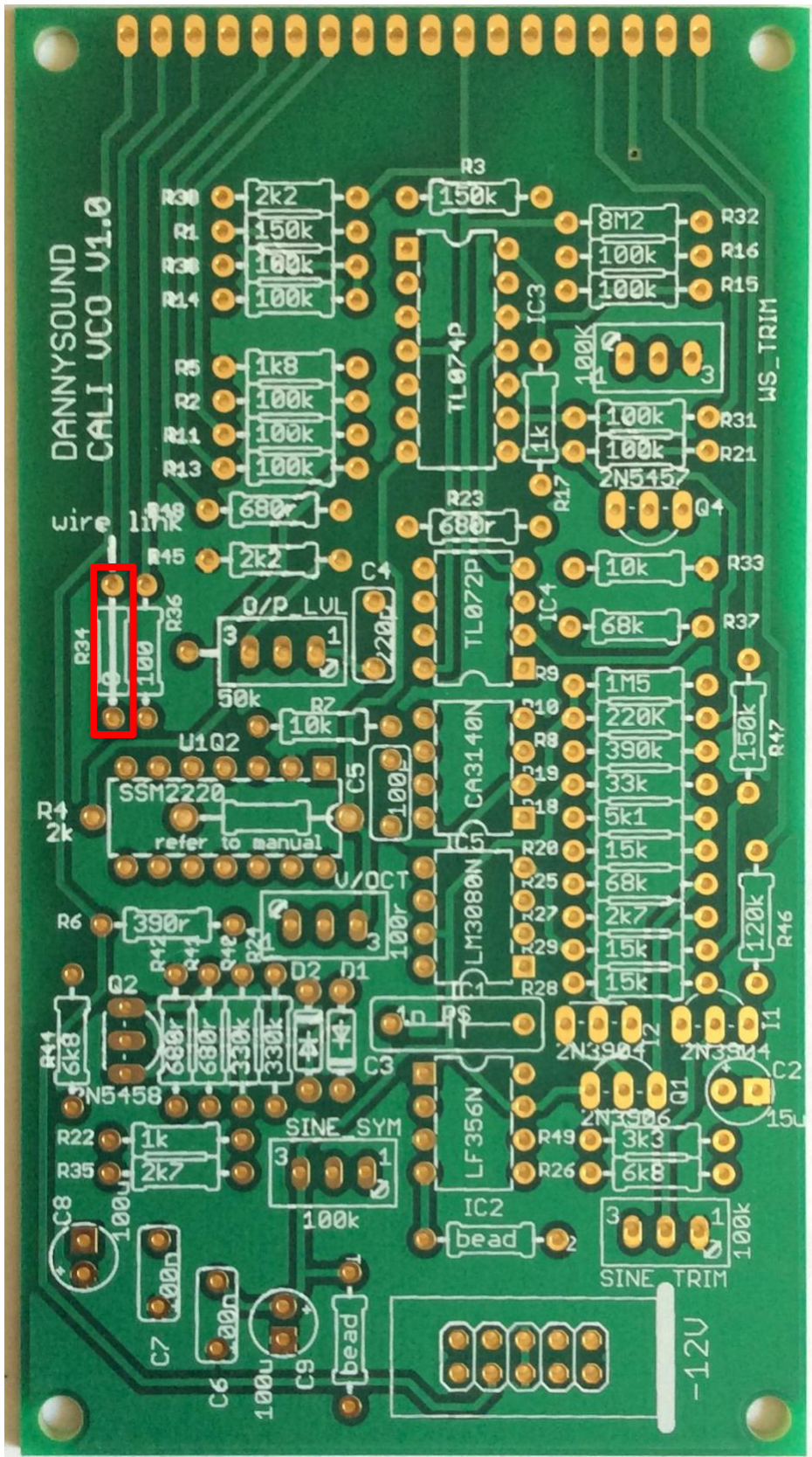

1 - wire link - solder a spare resistor leg between these holes

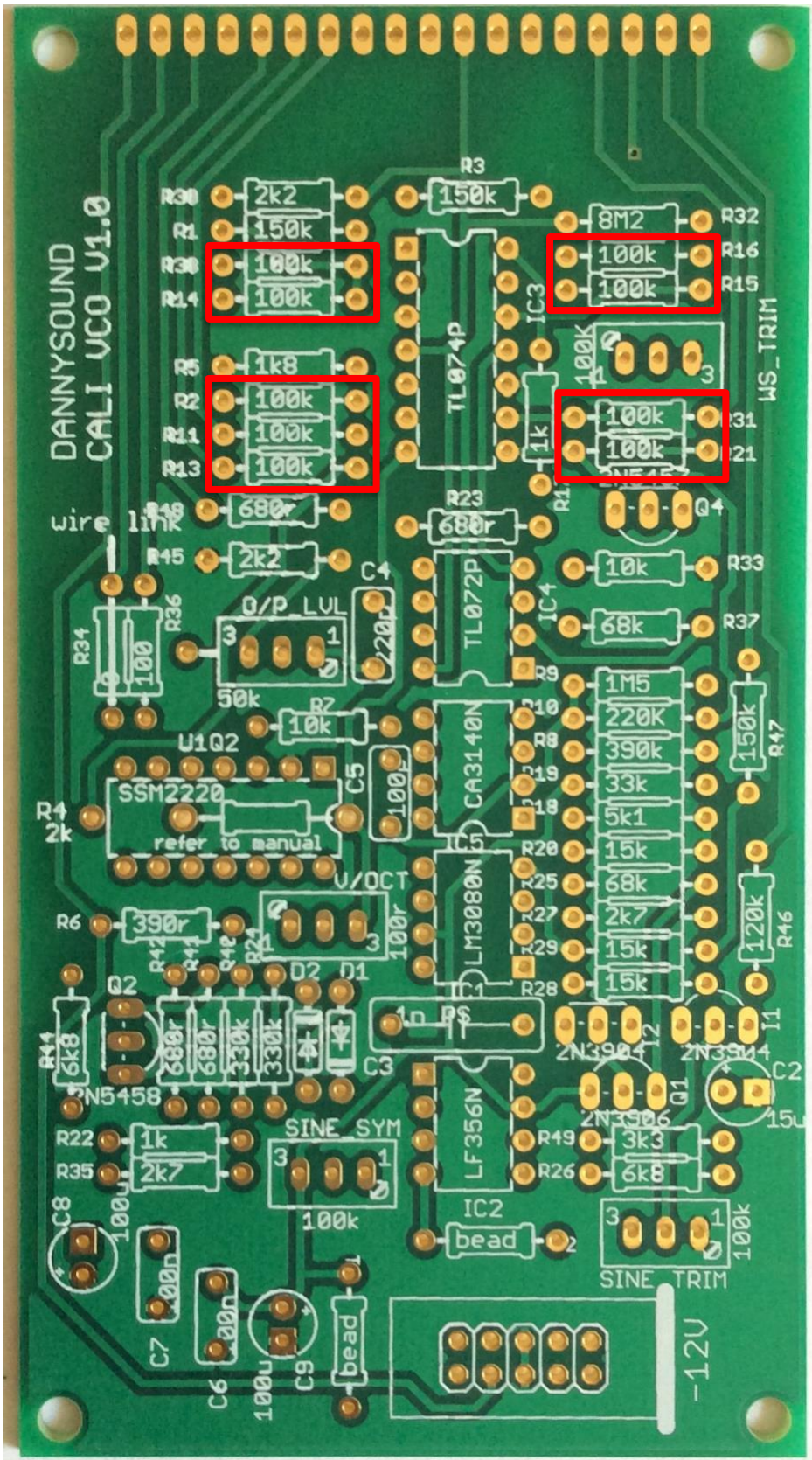

2 - 9 x 100k resistors

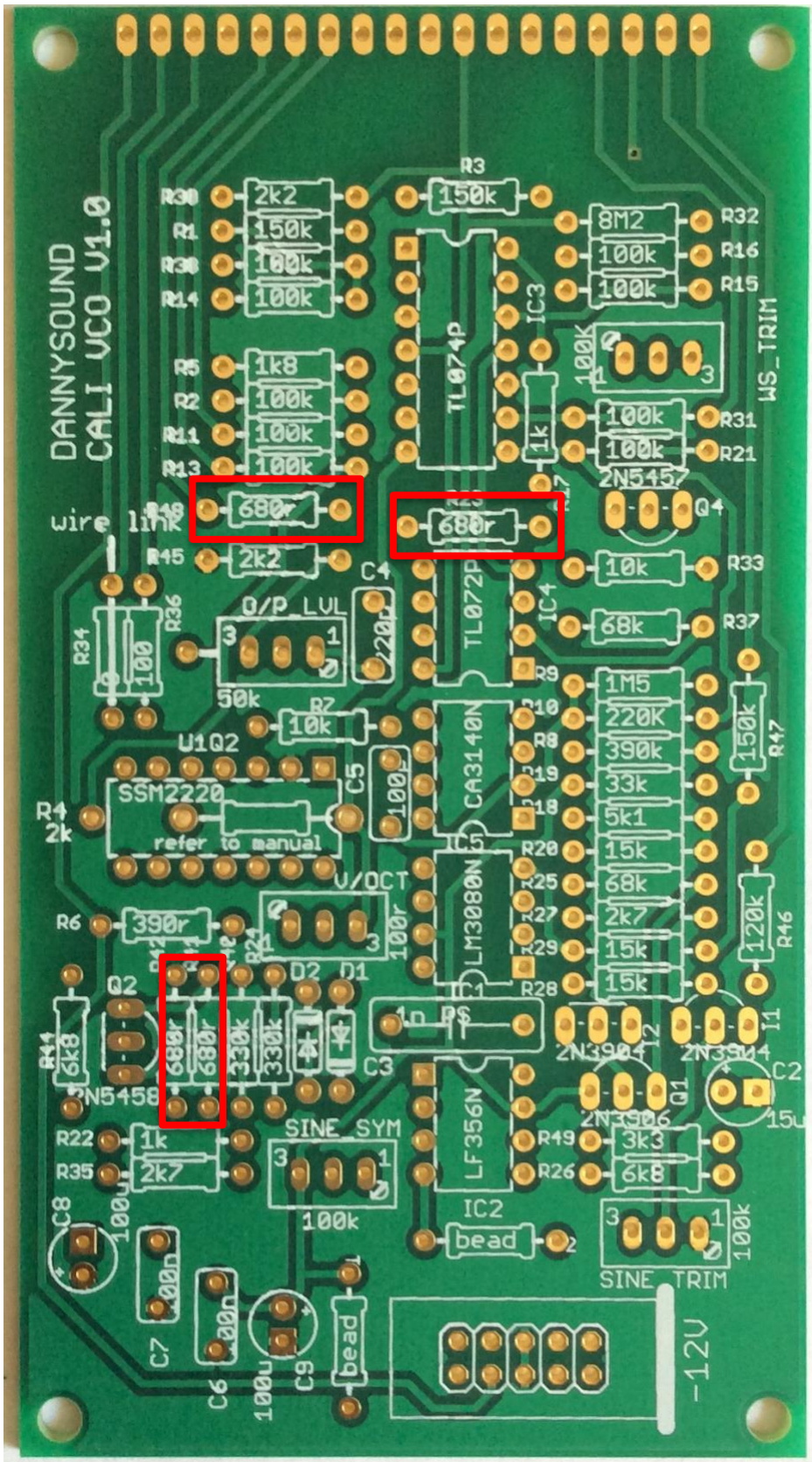

3 - 4 x 680r resistors

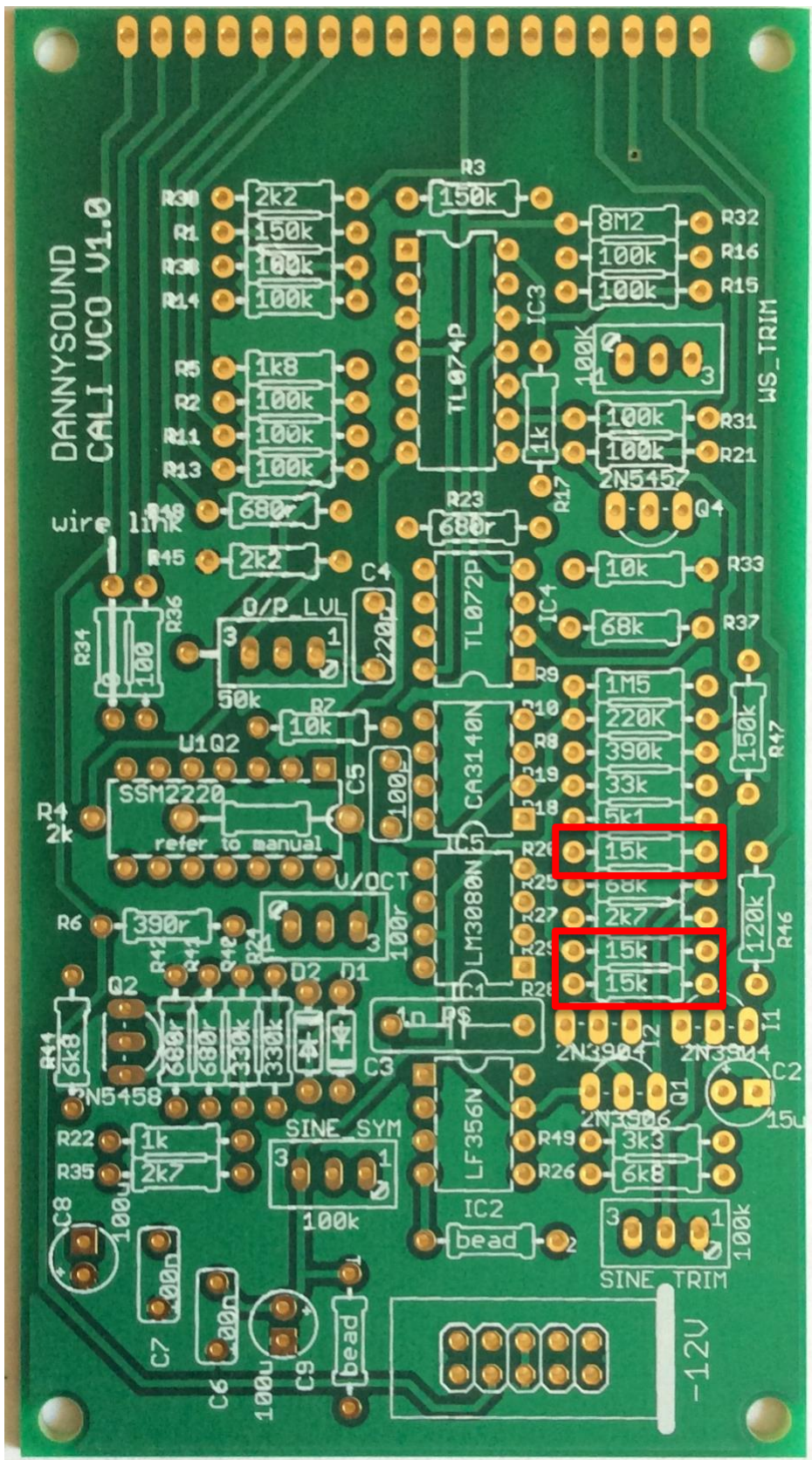

4 - 3 x 15k resistors

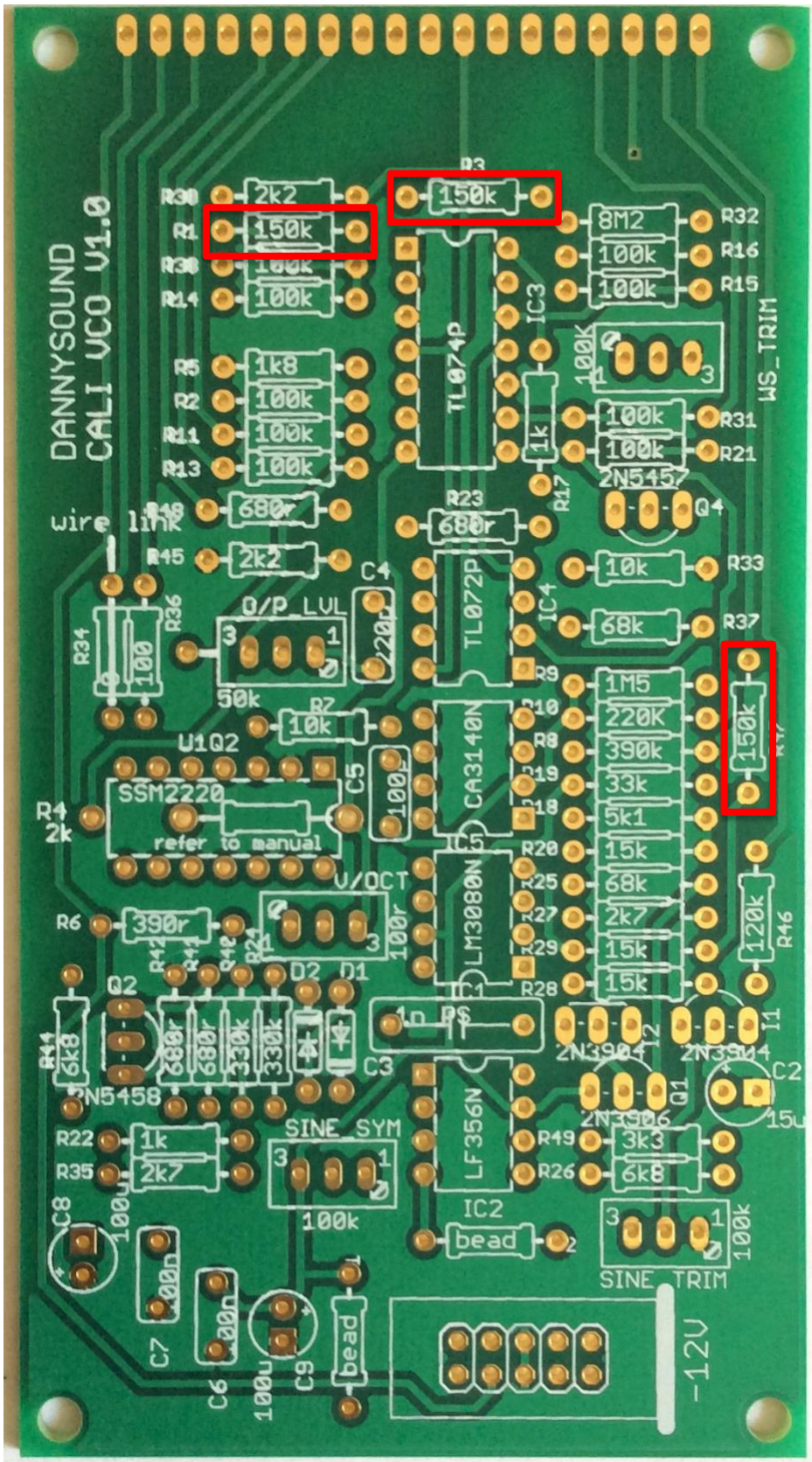

5 - 3 x 150k resistors

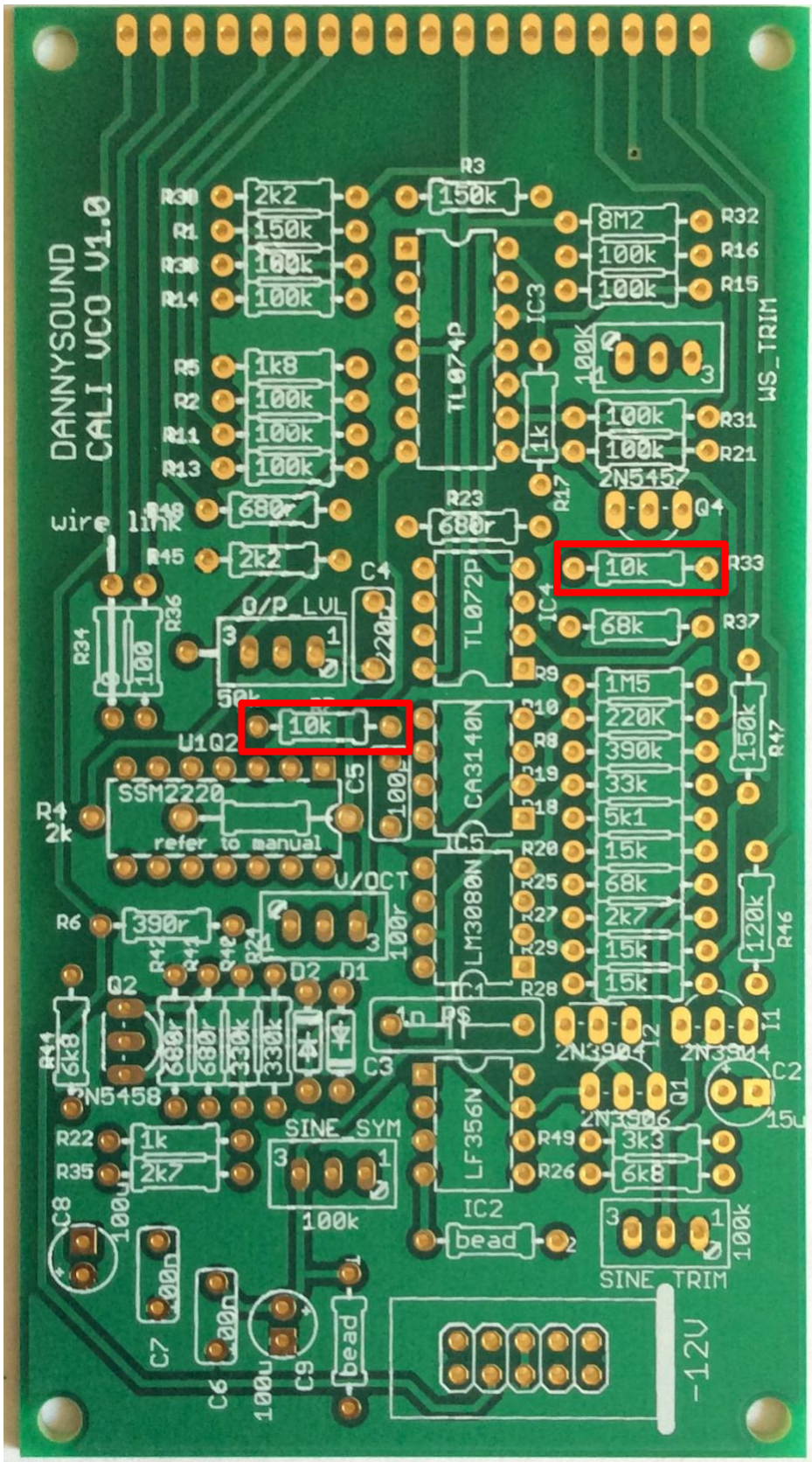

6 - 2 x 10k resistors

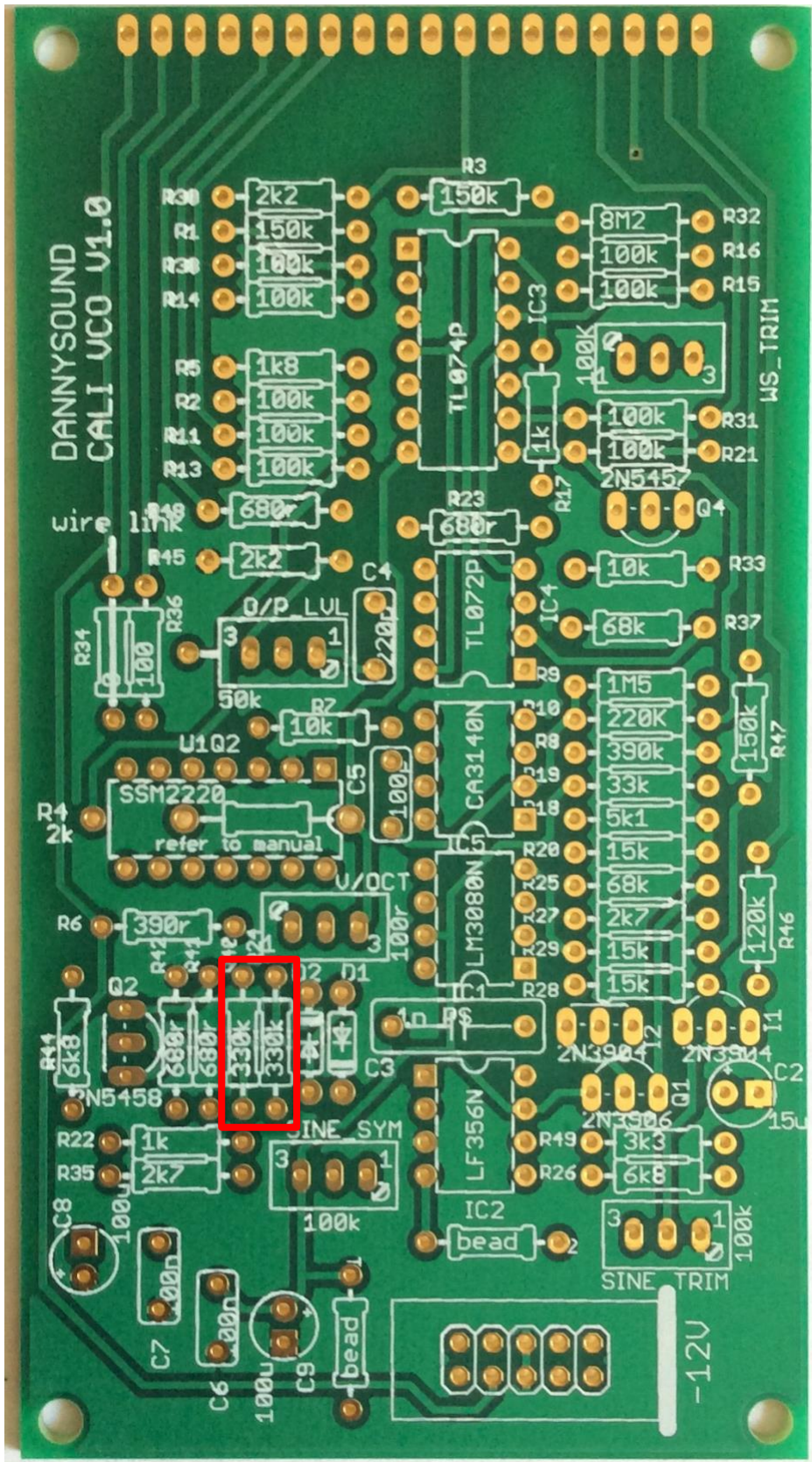

7 - 2 x 330k resistors

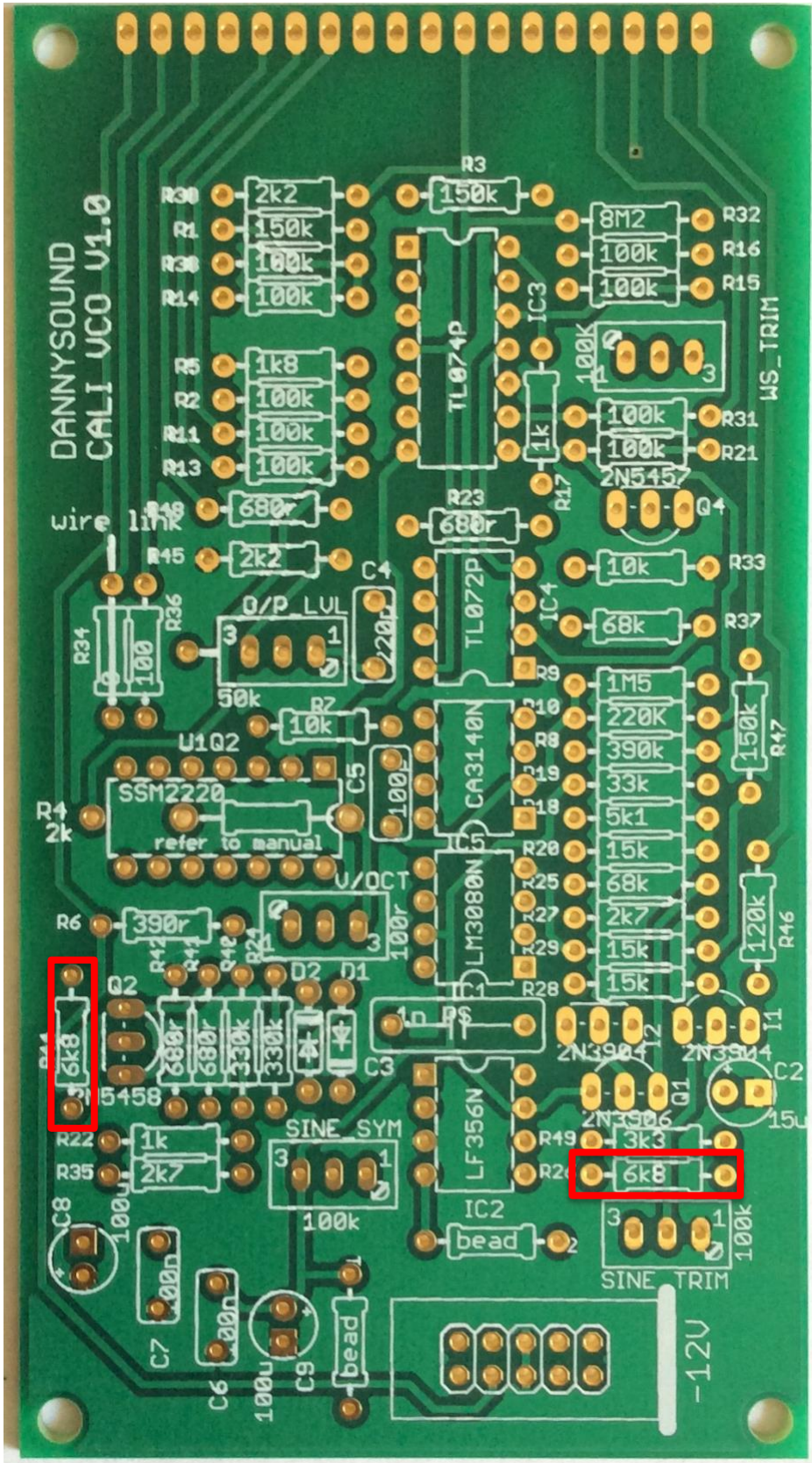

8 - 2 x 6k8 resistors

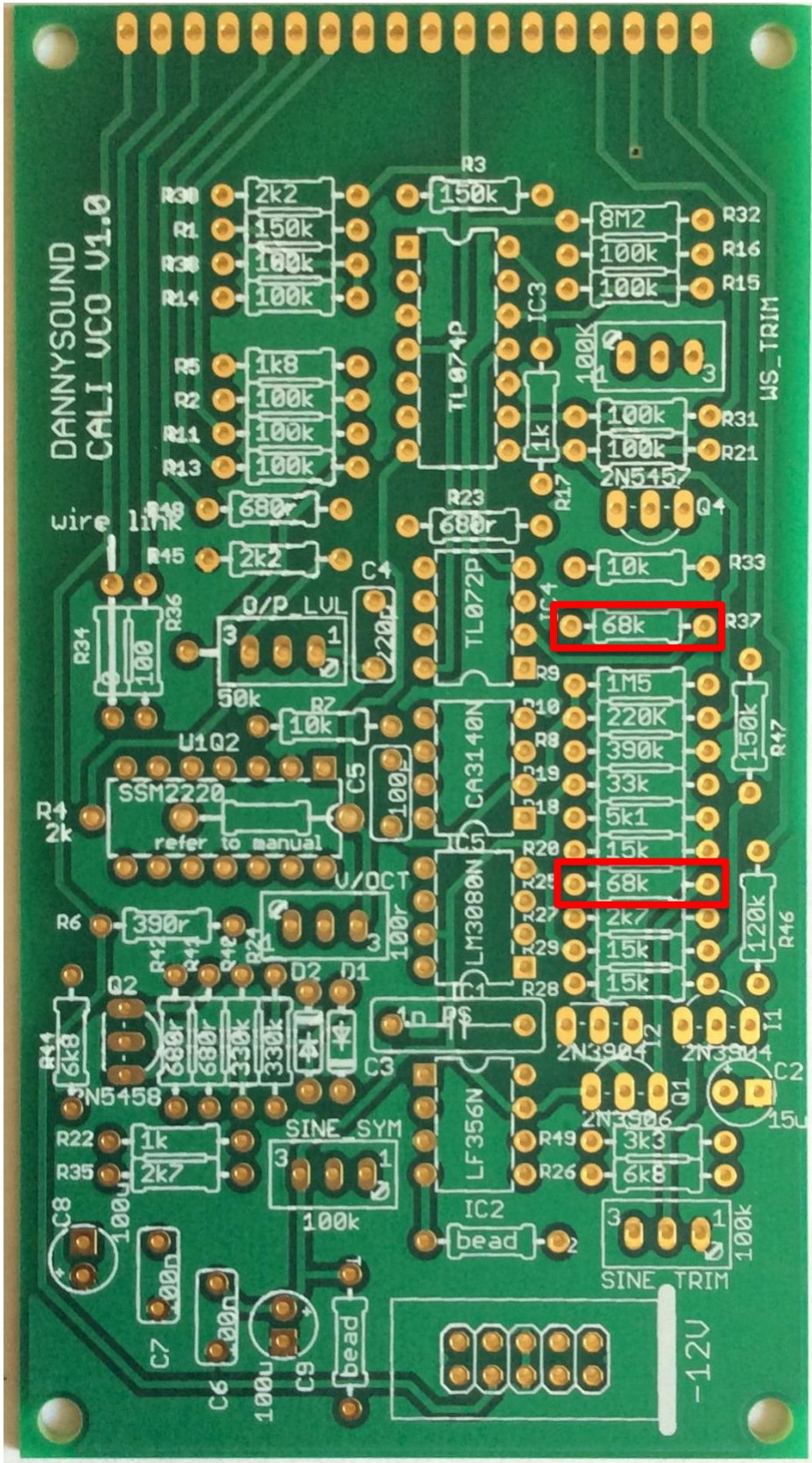

9 - 2 x 68k resistors

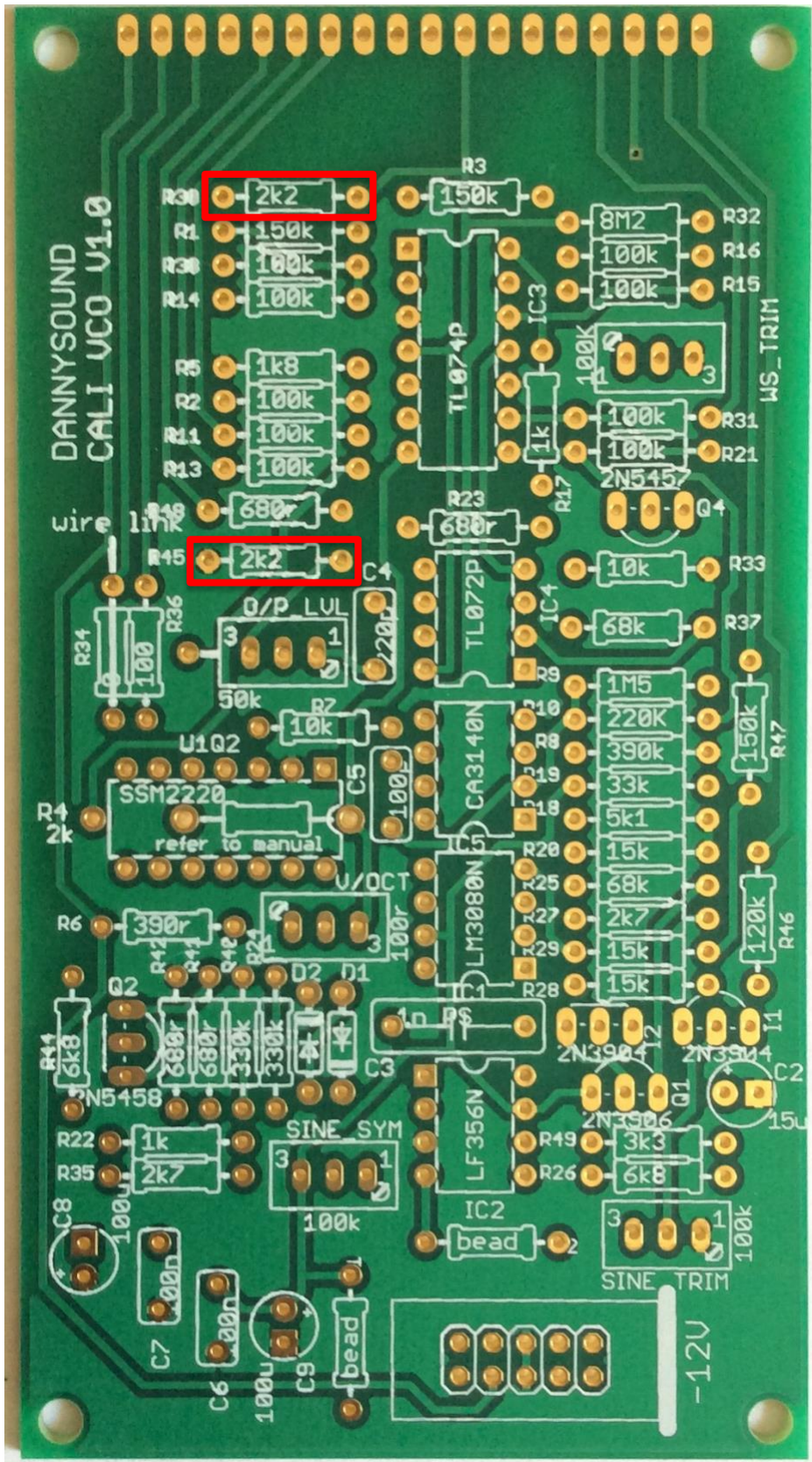

10 - 2 x 2k2 resistors

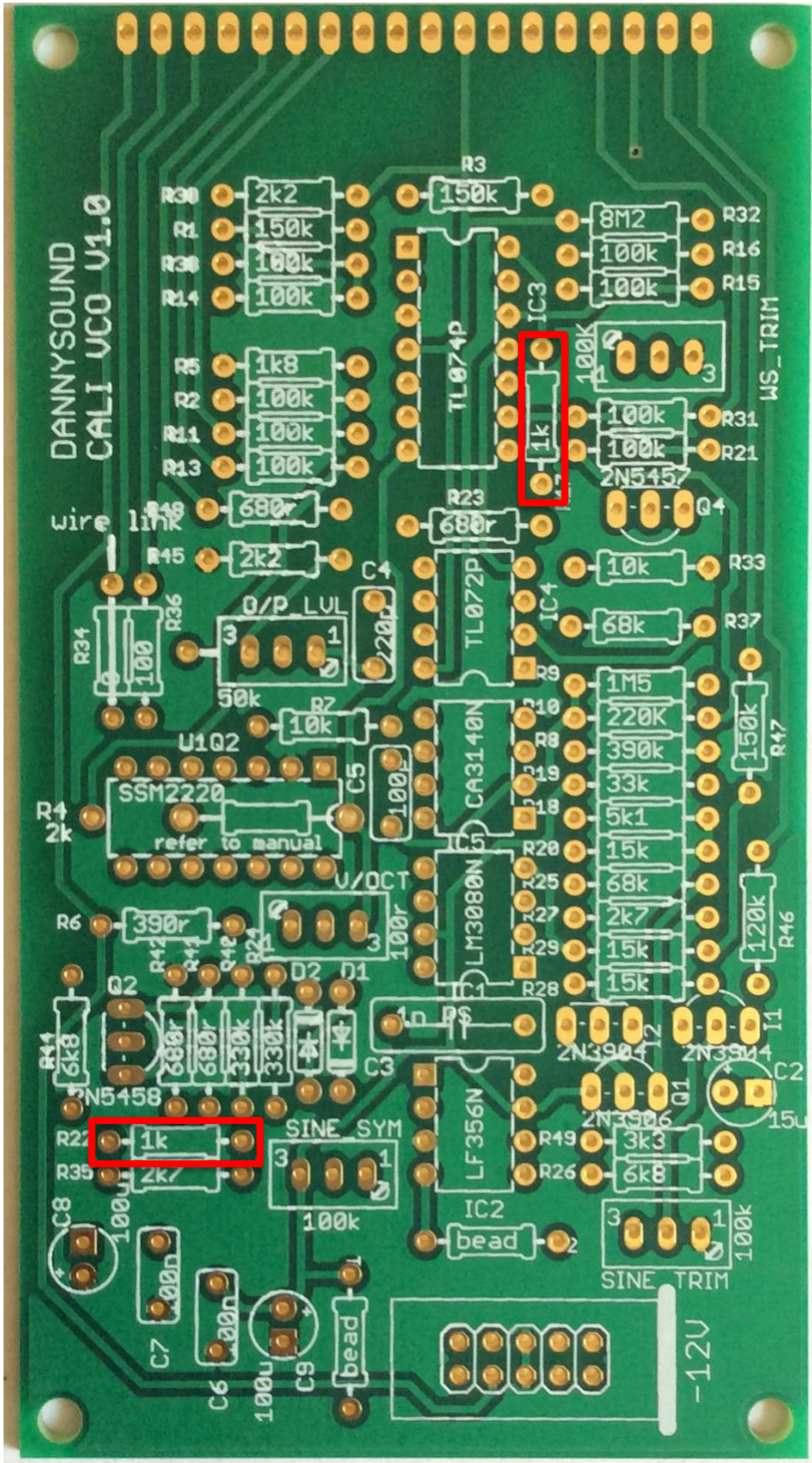

11 - 2 x 1k resistors

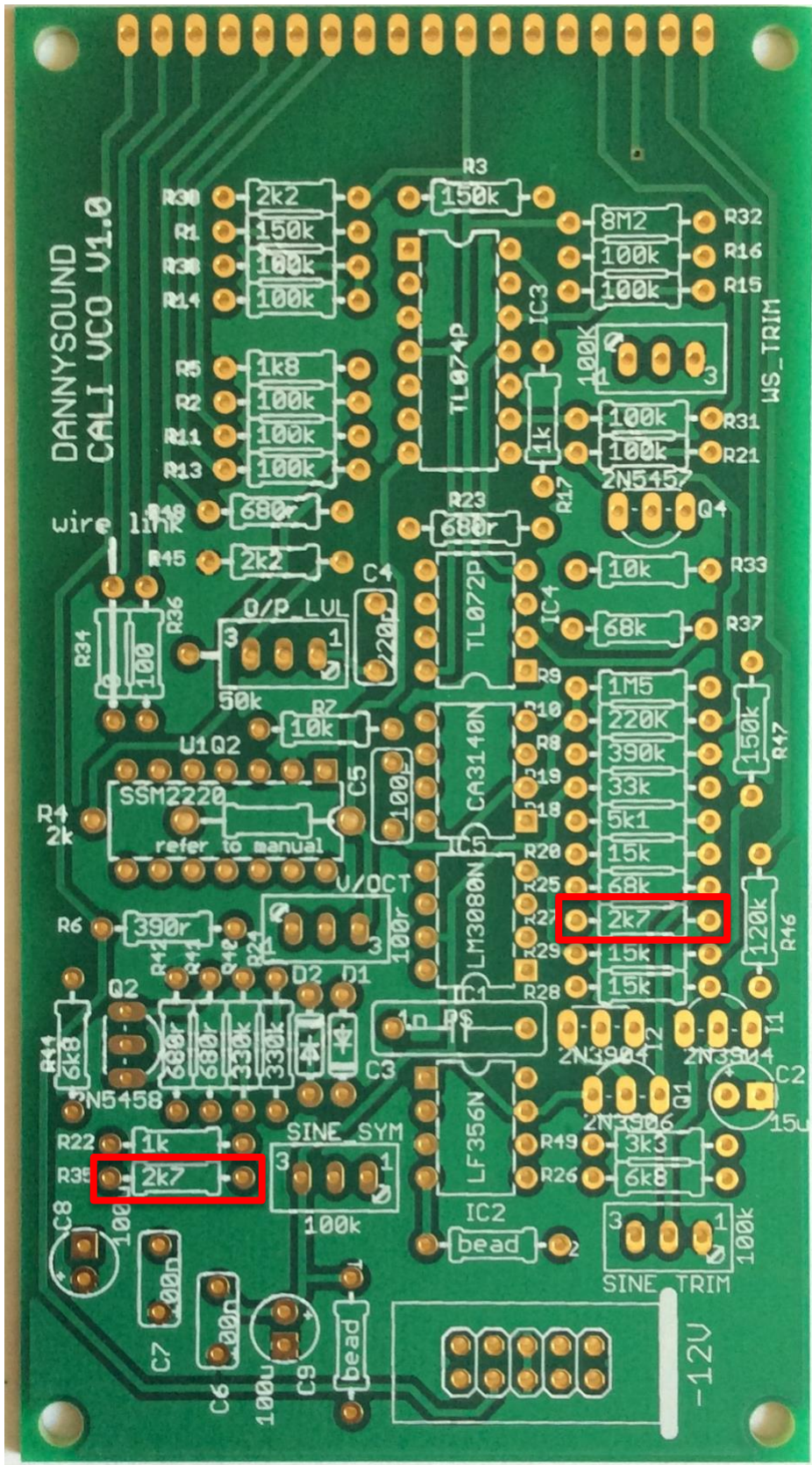

12 - 2 x 2k7 resistors

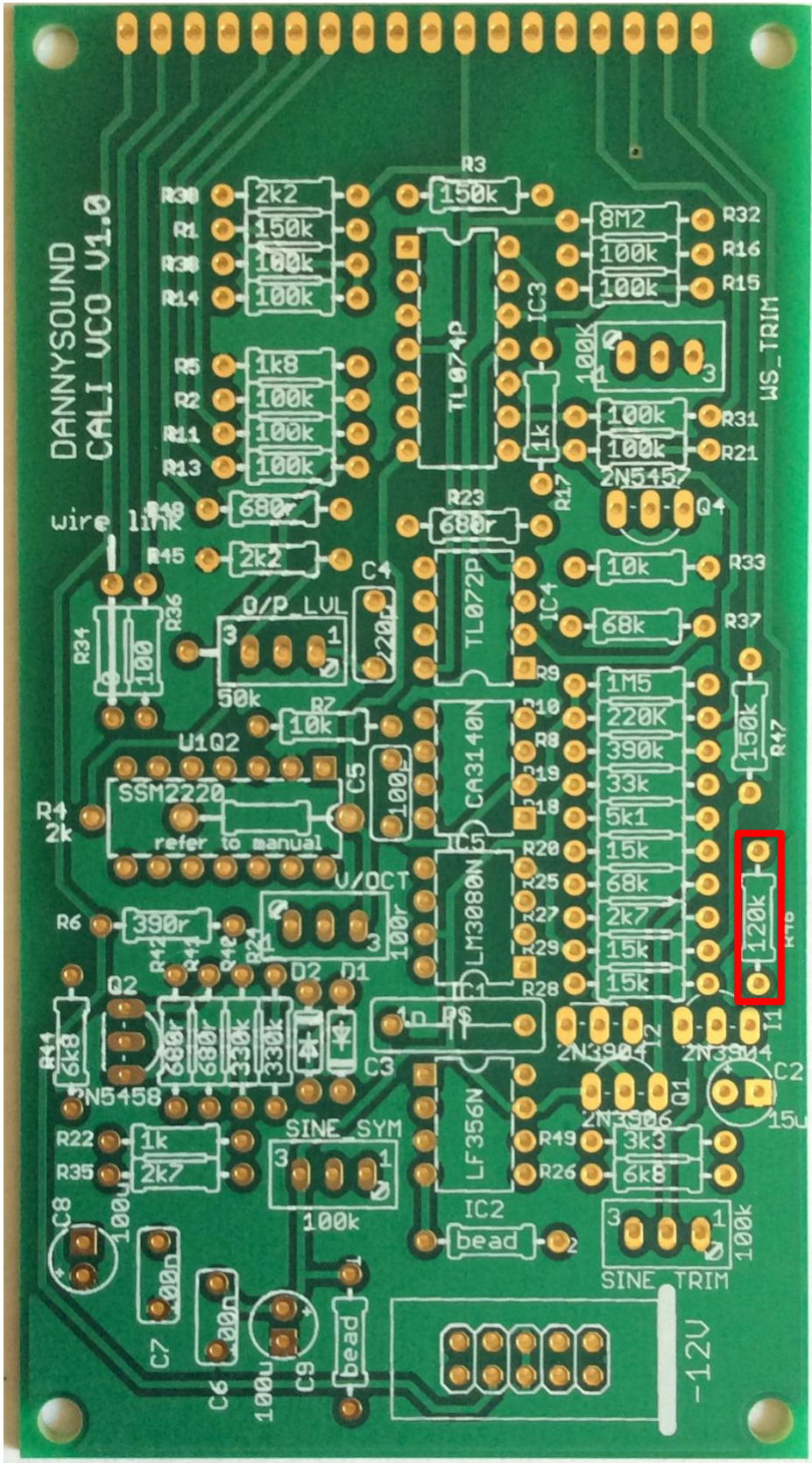

13 - 1 x 120k resistors

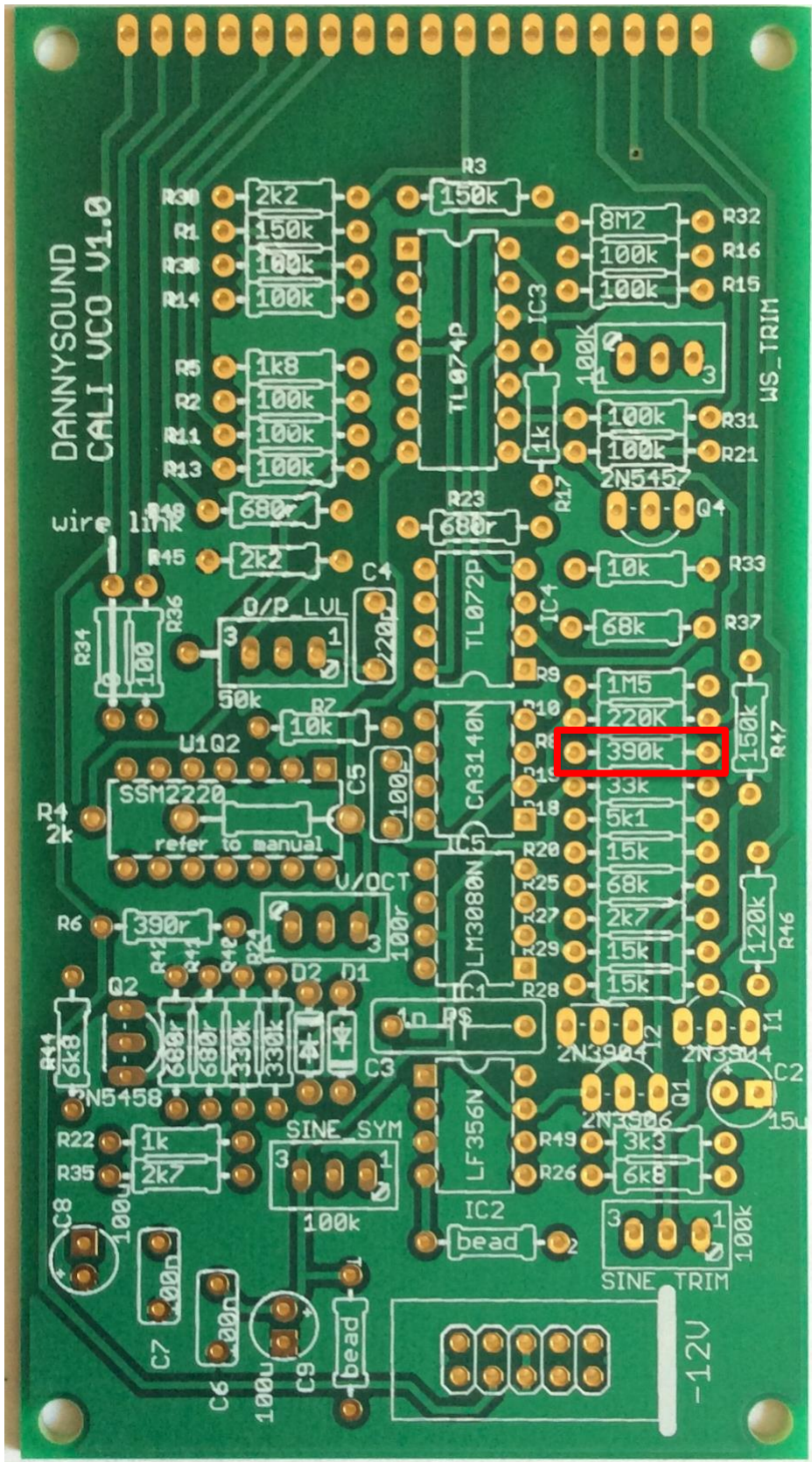

14 - 1 x 390k resistors

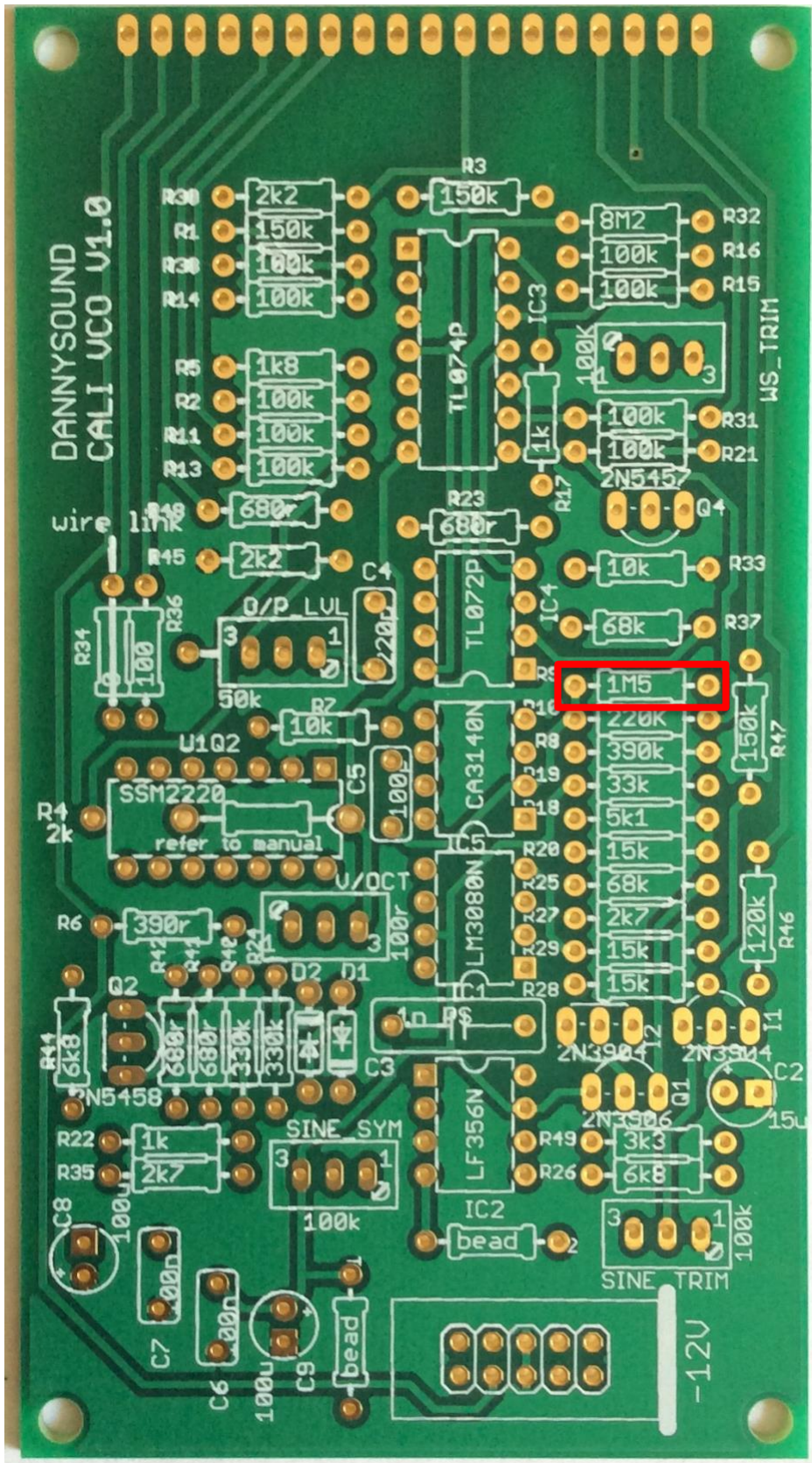

15 - 1 x 1M5 resistors

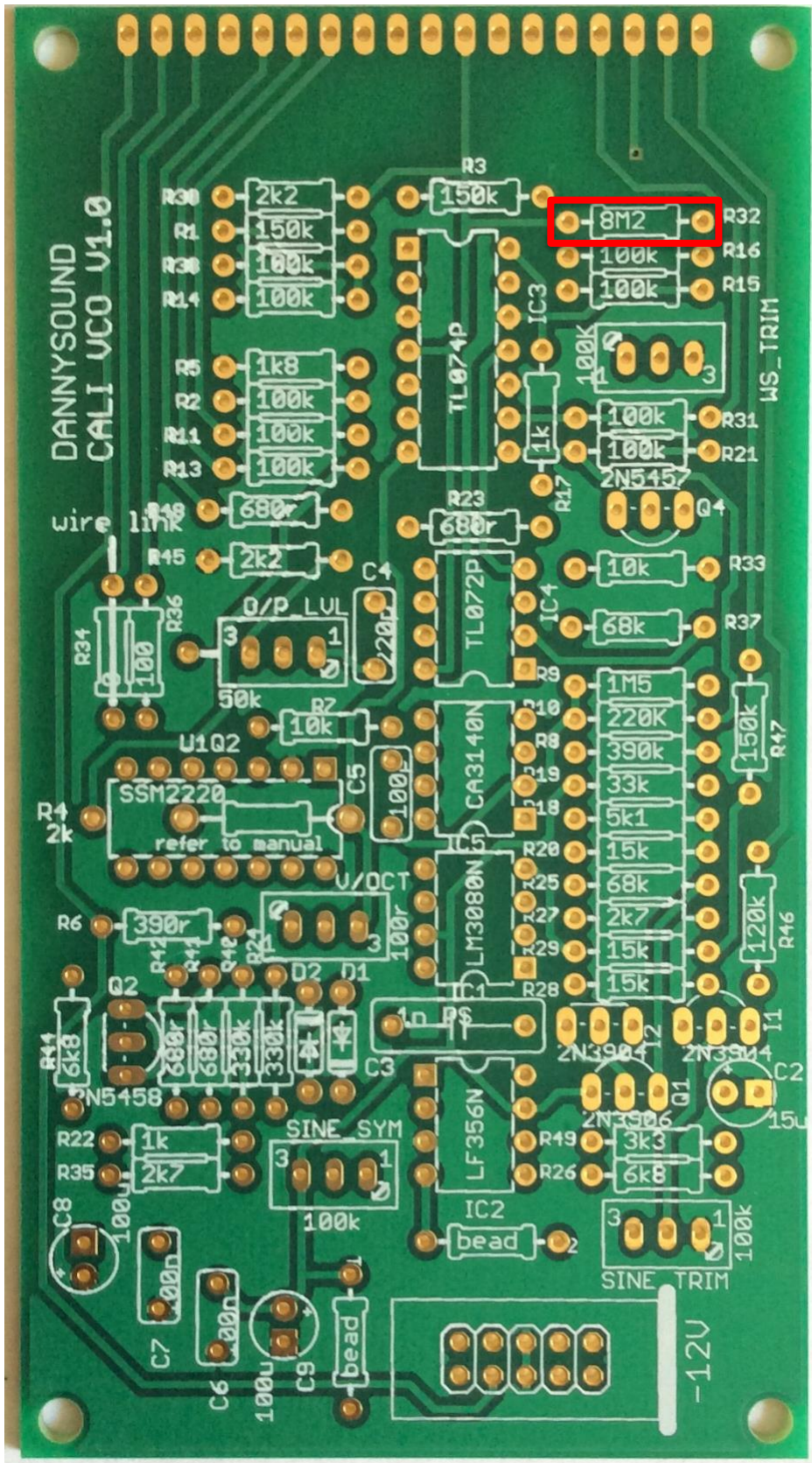

16 - 1 x 8M2 resistors

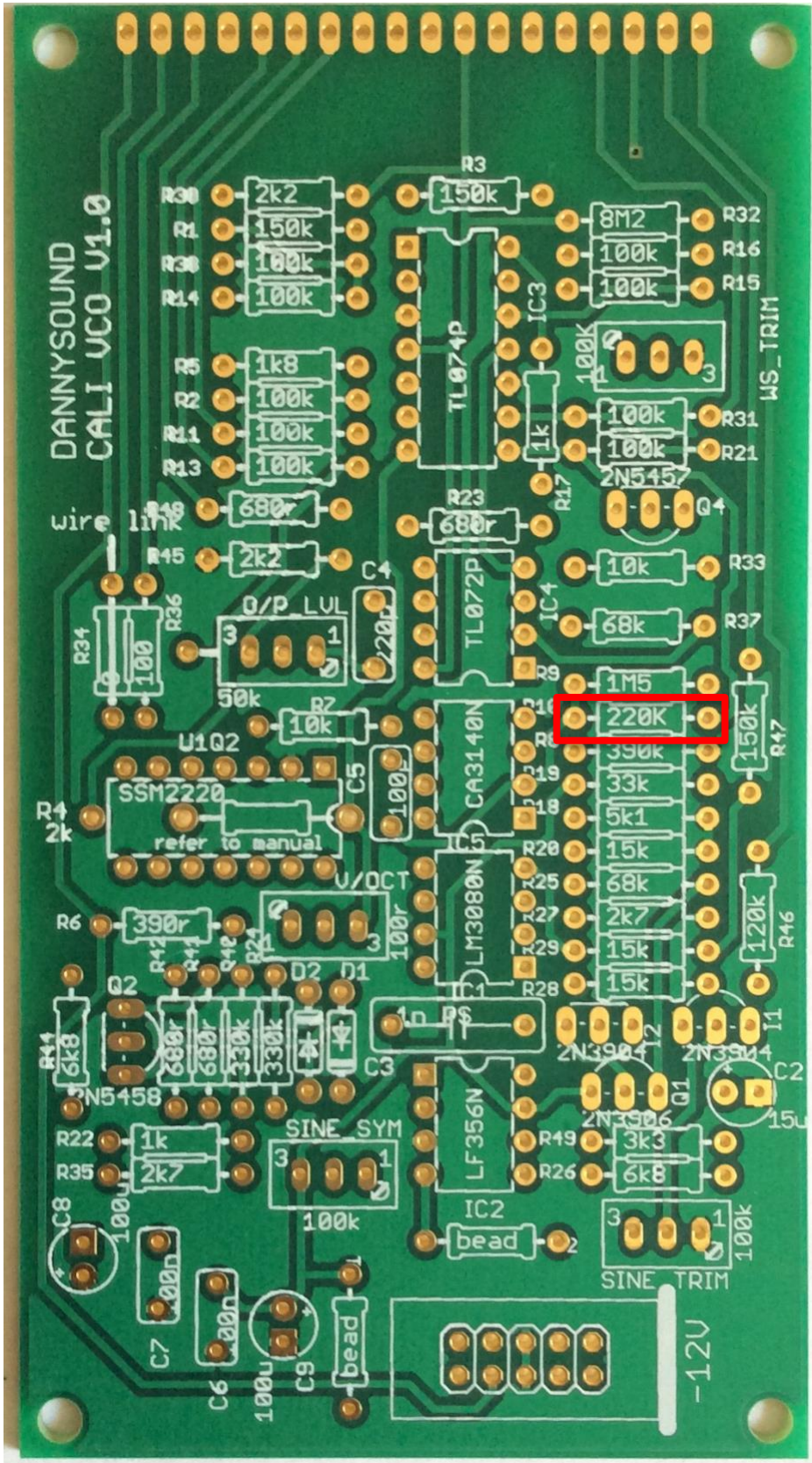

17 - 1 x 220k resistors

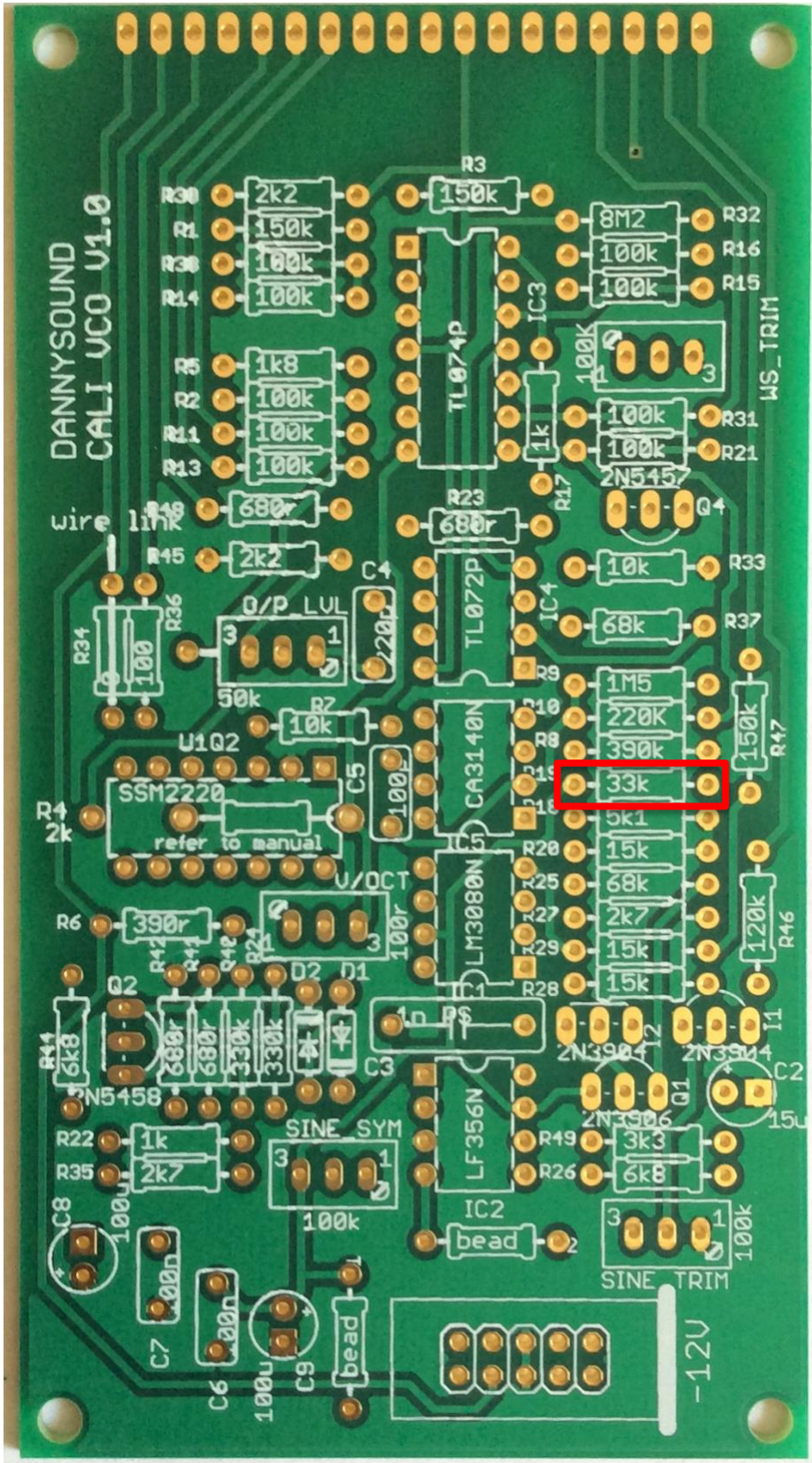

18 - 1 x 33k resistors

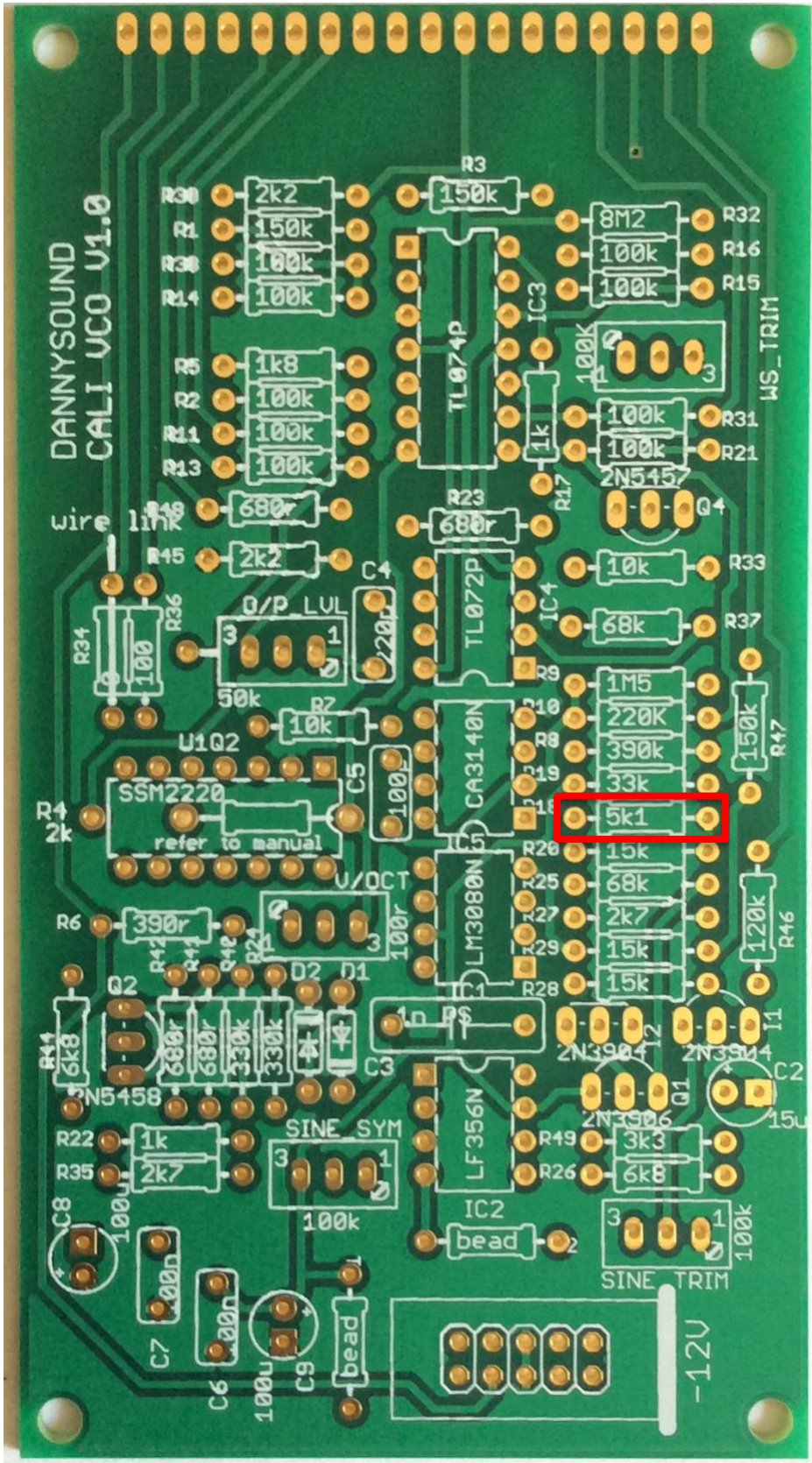

19 - 1 x 5k1 resistors

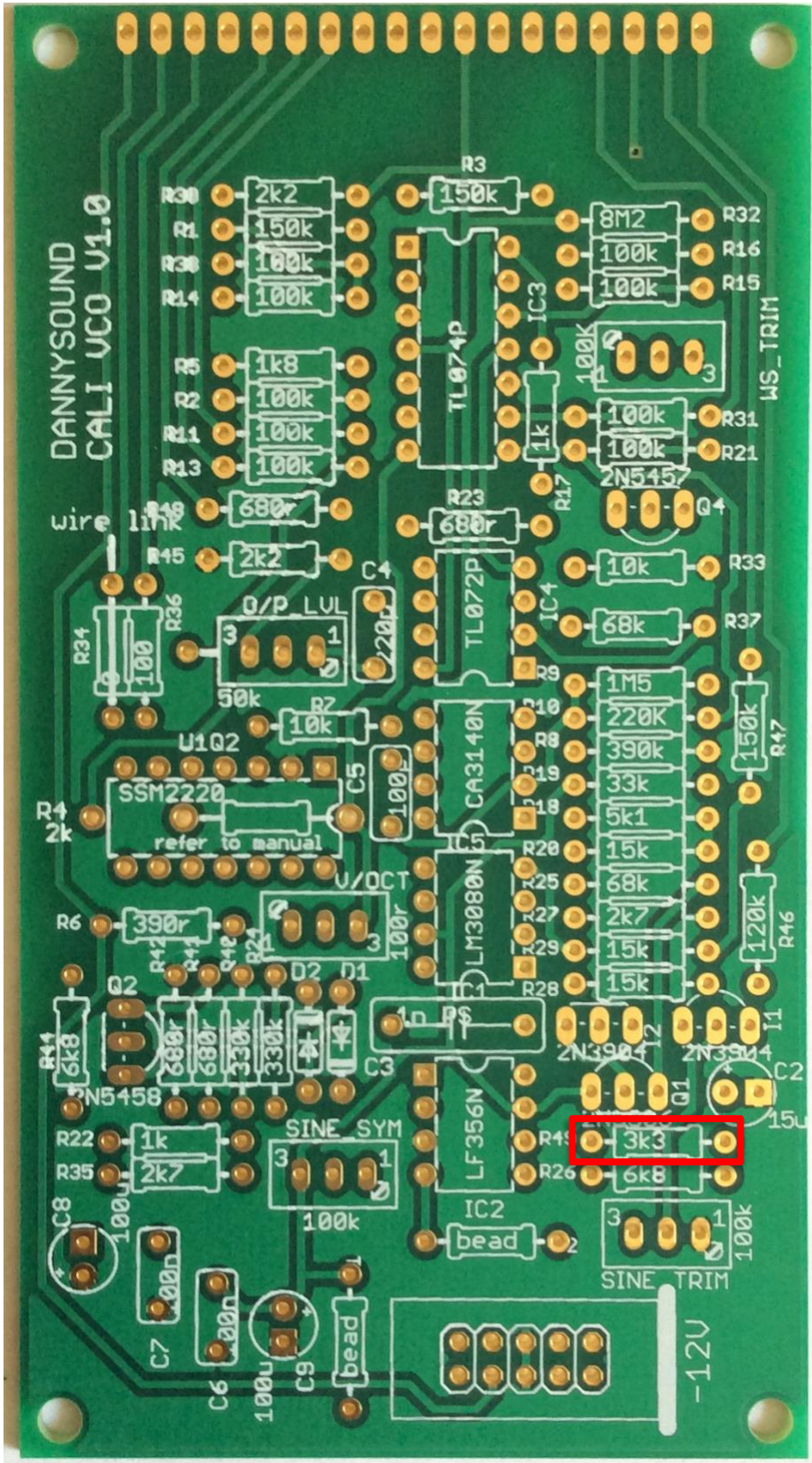

20 - 1 x 3k3 resistors

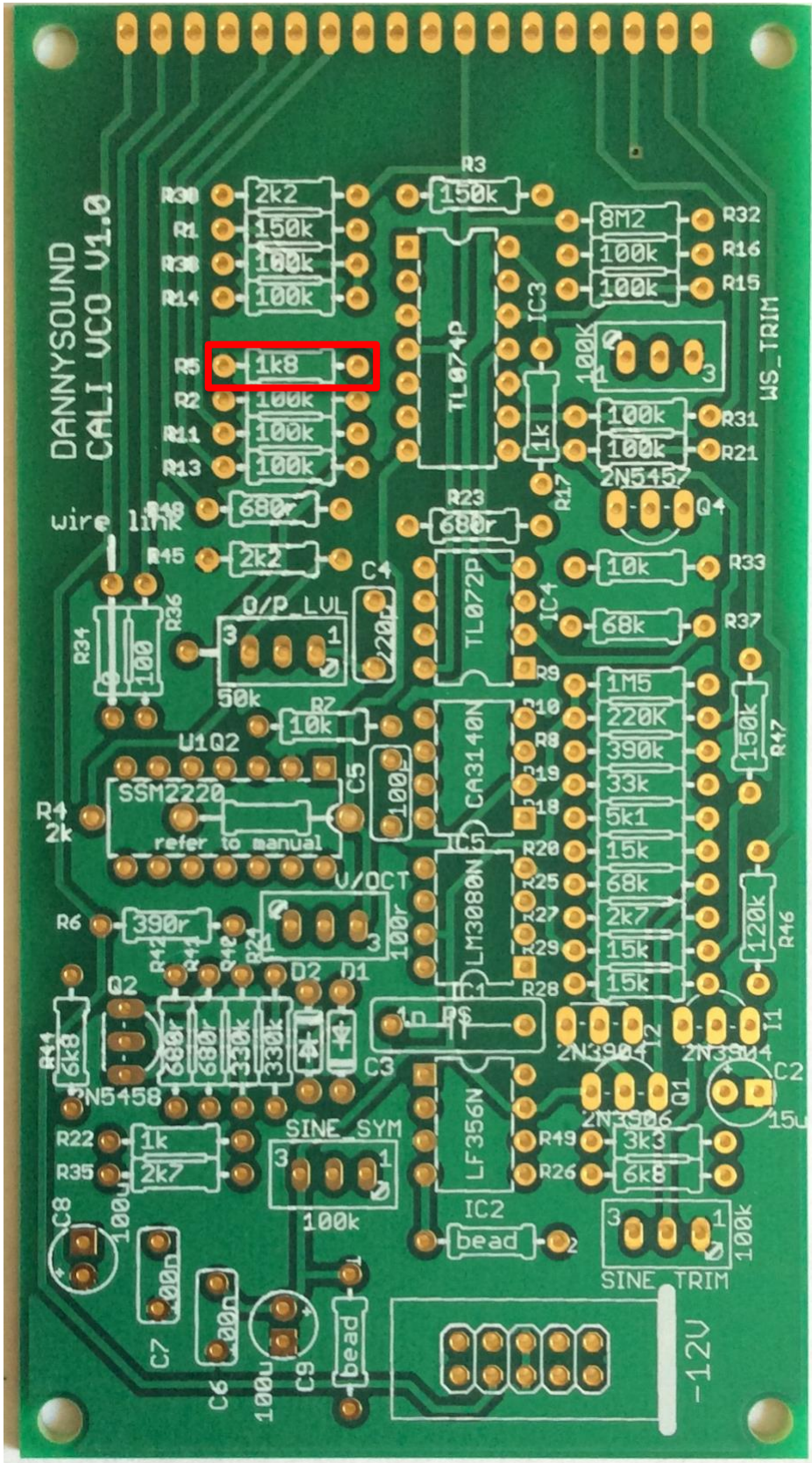

21 - 1 x 1k8 resistors

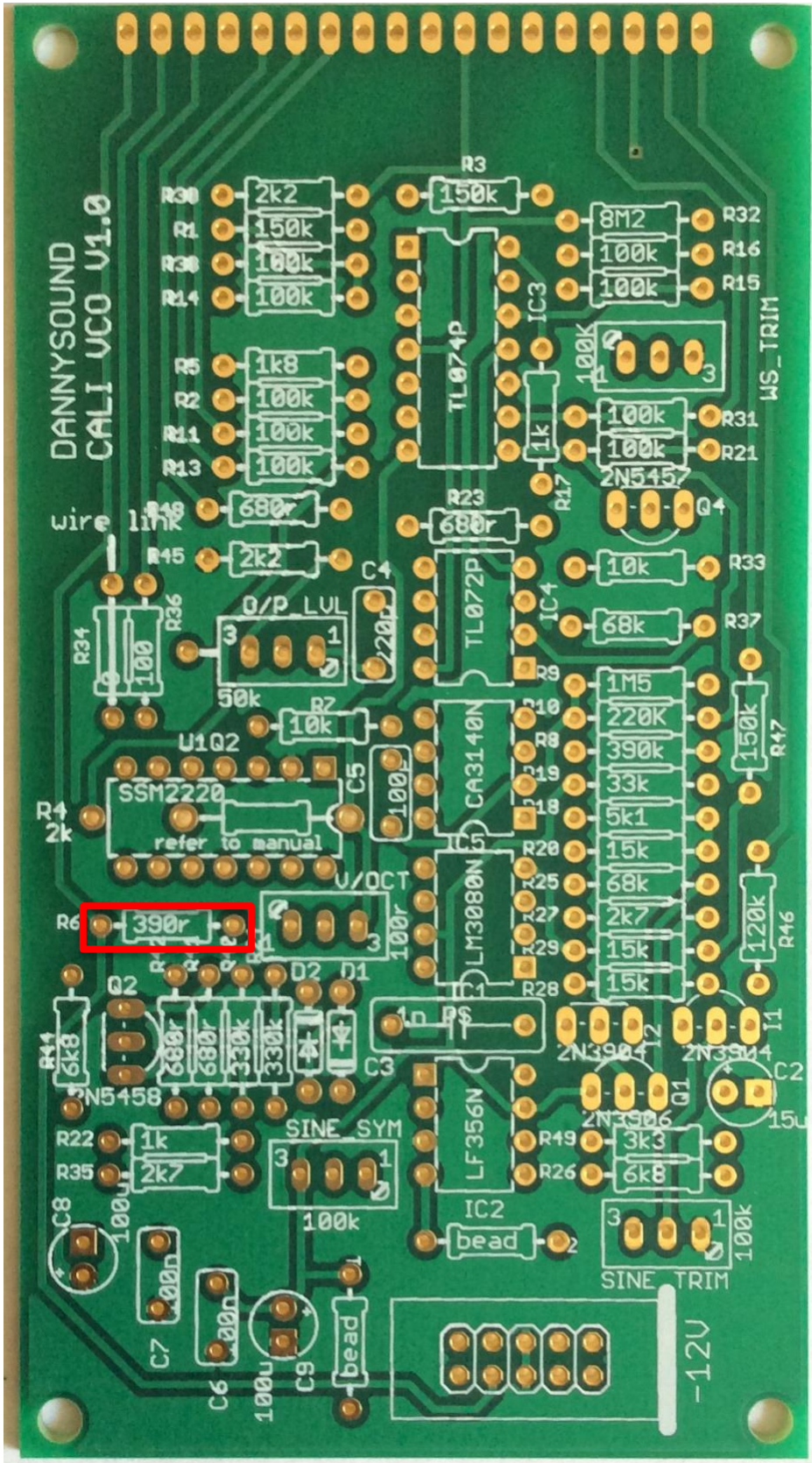

22 - 1 x 390r resistors

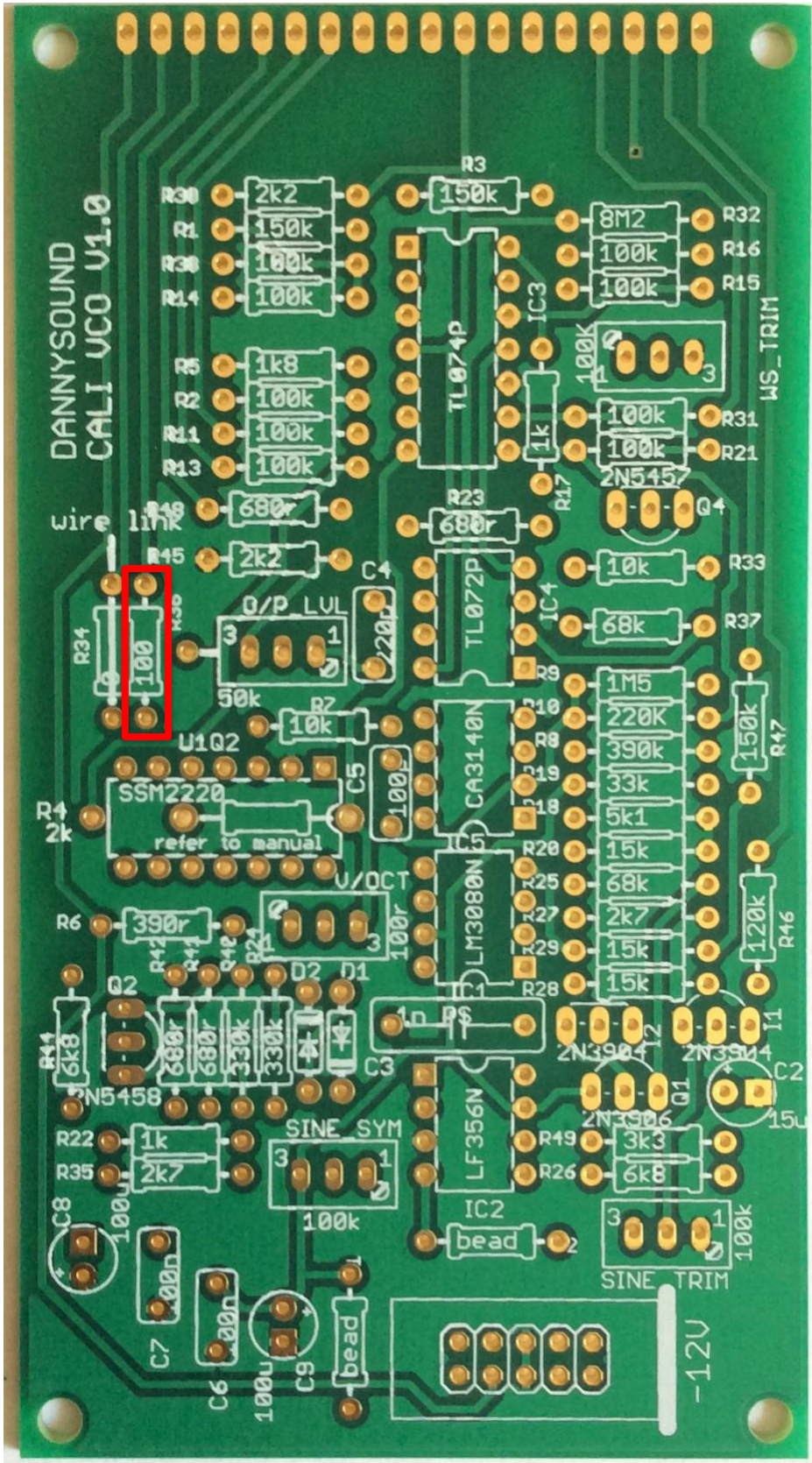

23 - 1 x 100r resistors

Diodes

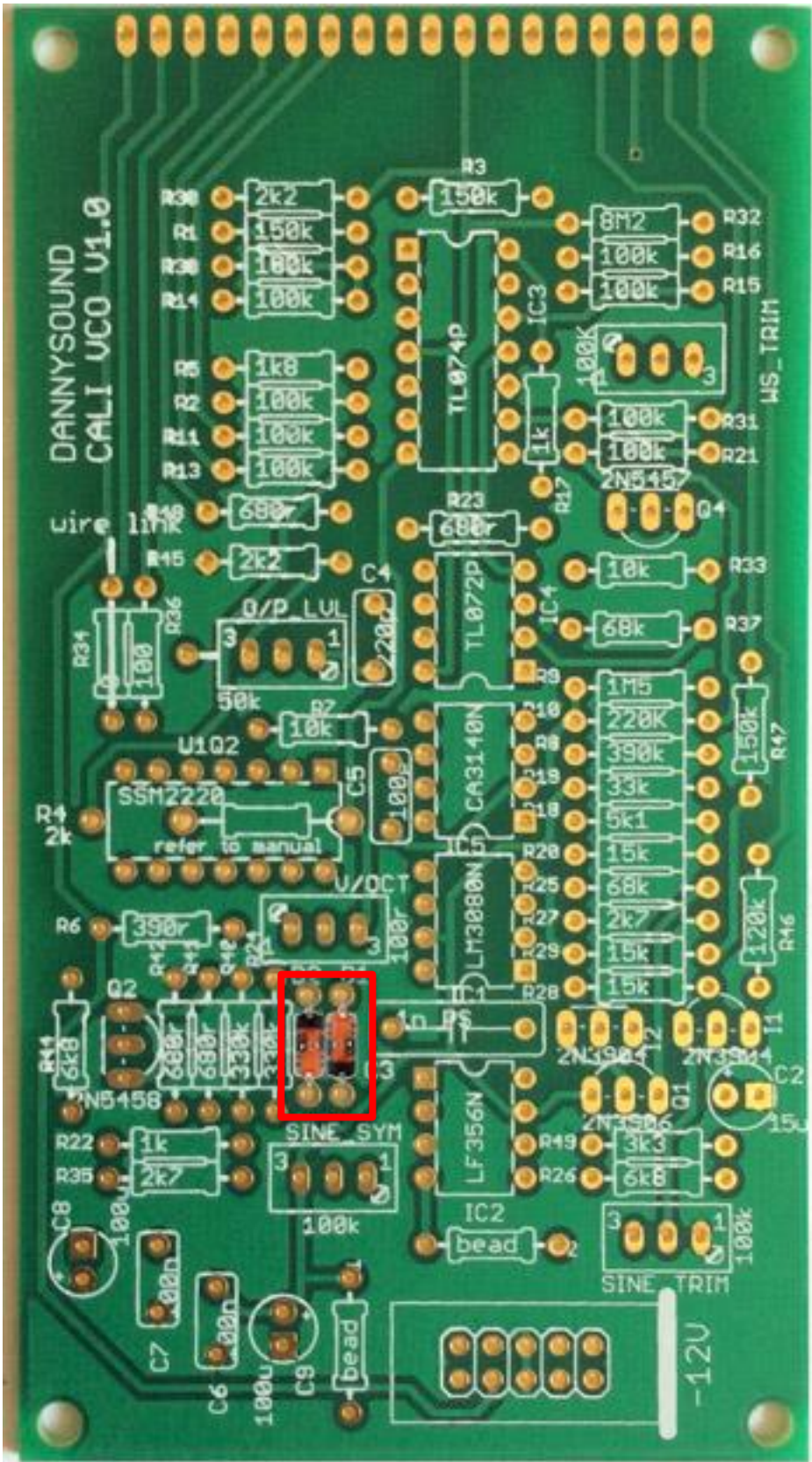

24 – 2 x 1N4148 diodes - Note: orientation of this part is vital, be sure to match the line on the component with that on the PCB silkscreen

Inductors

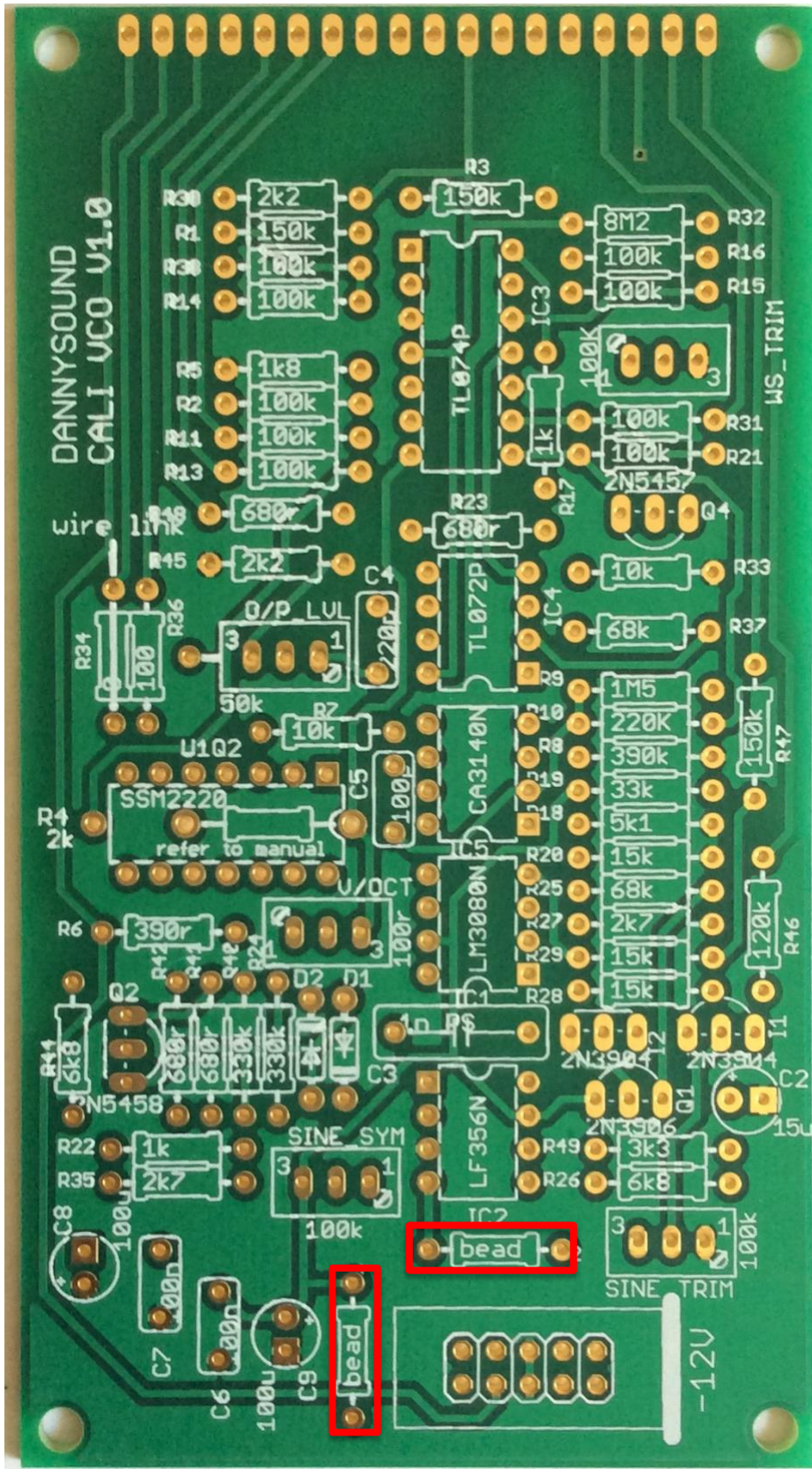

25 - 2 x bead inductors

IC Sockets

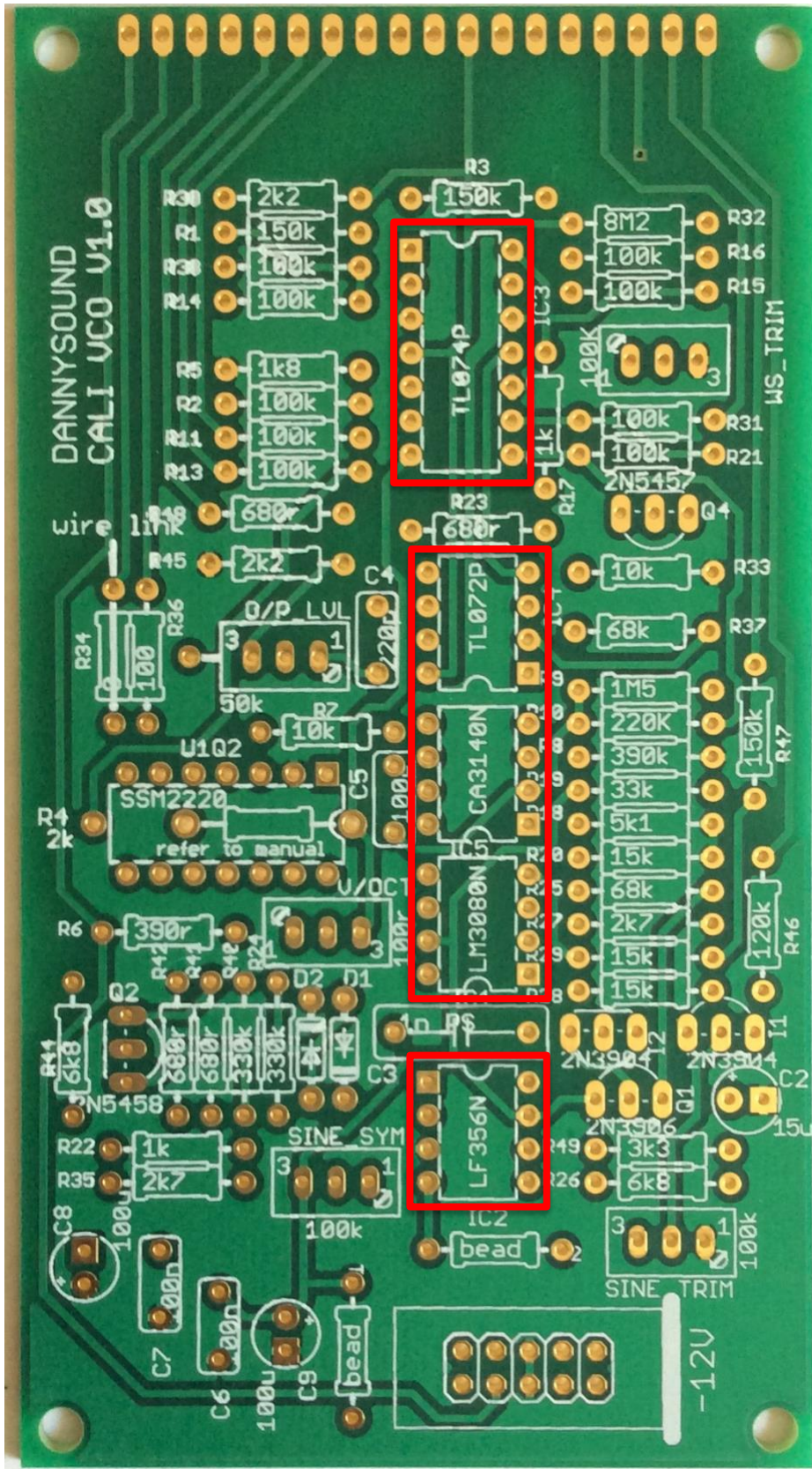

26 - IC sockets - Make sure the notches in the sockets match the notches on the silkscreen.

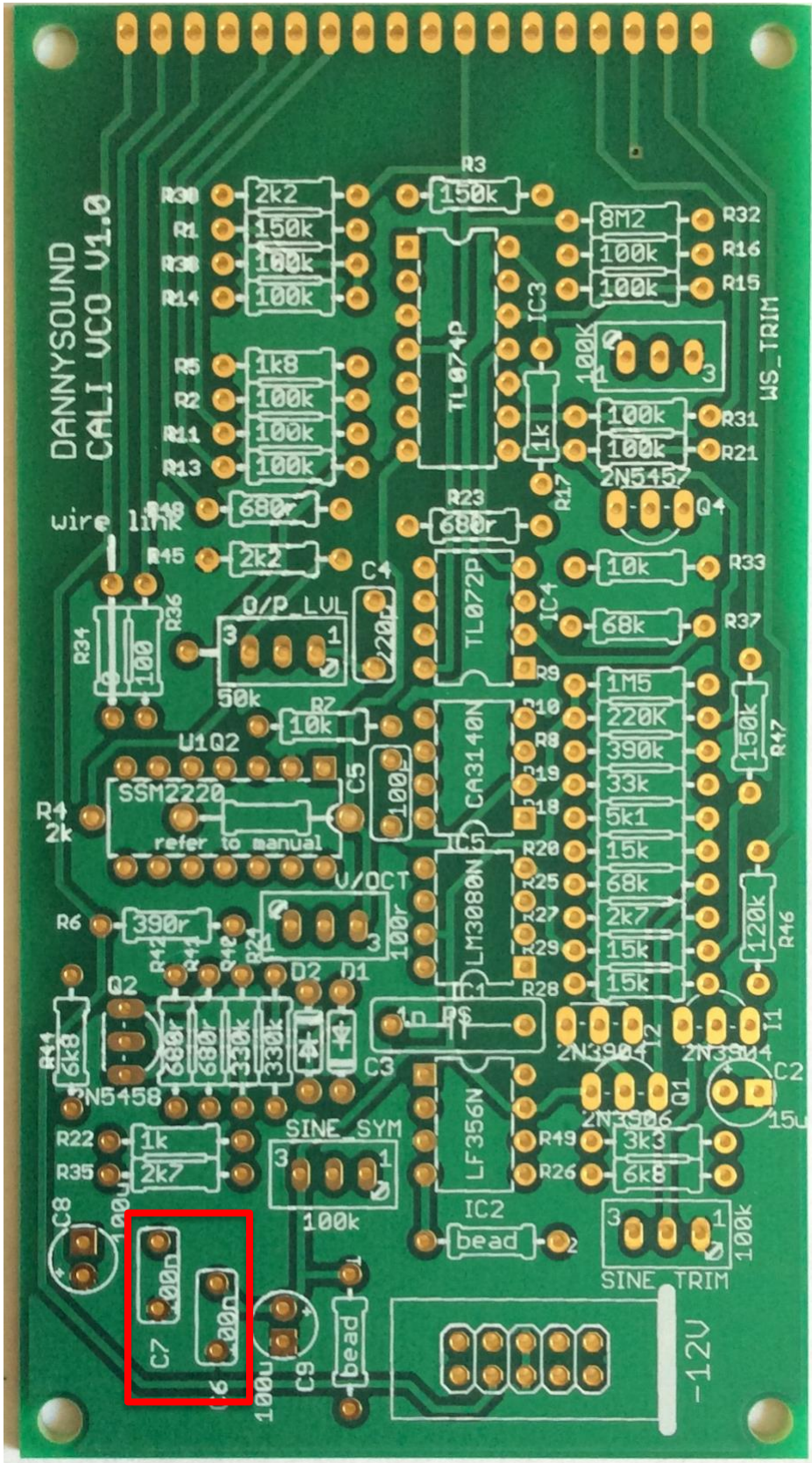

27 - 2 x 100nF capacitors

Capacitors

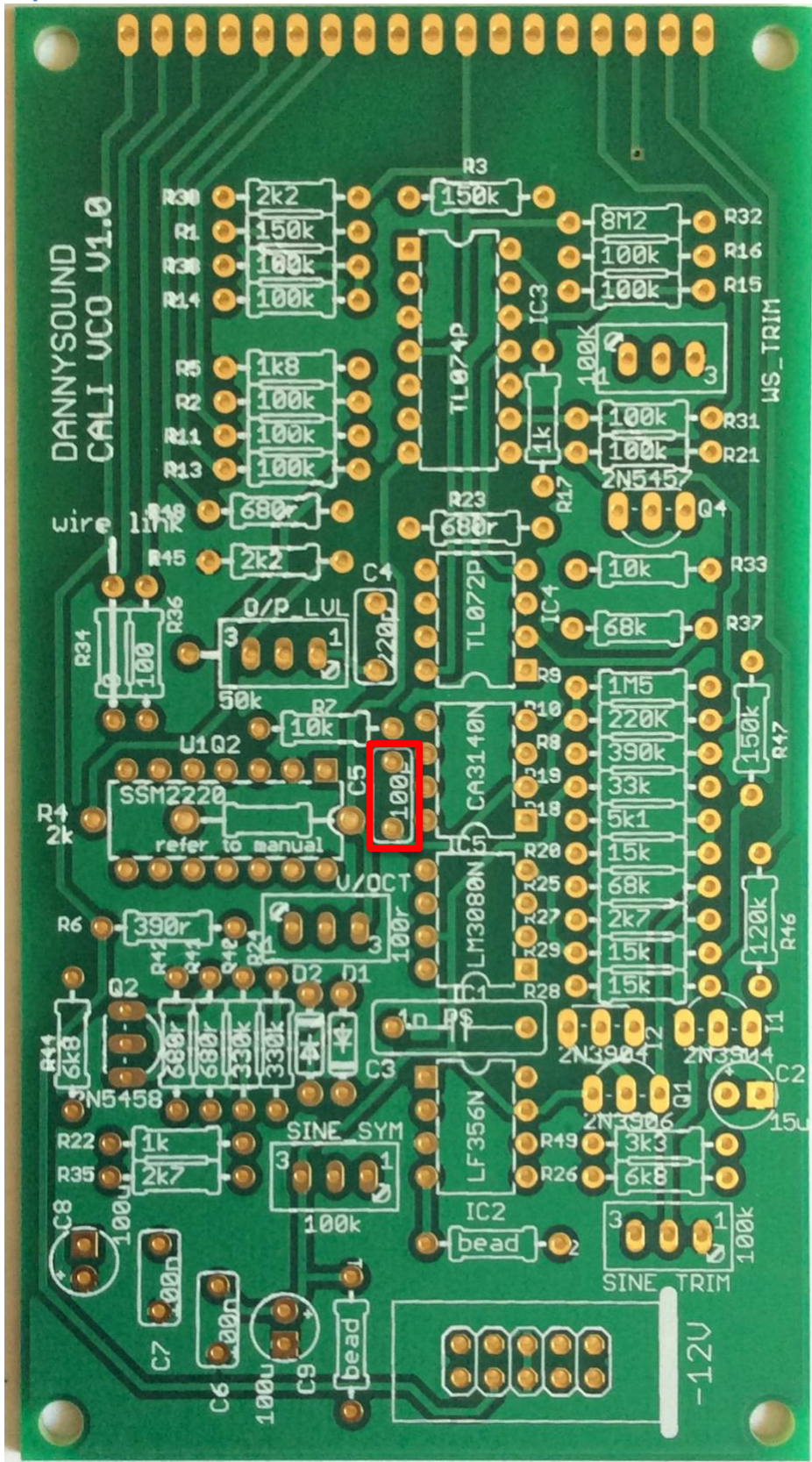

28 - 1 x 100pF capacitors

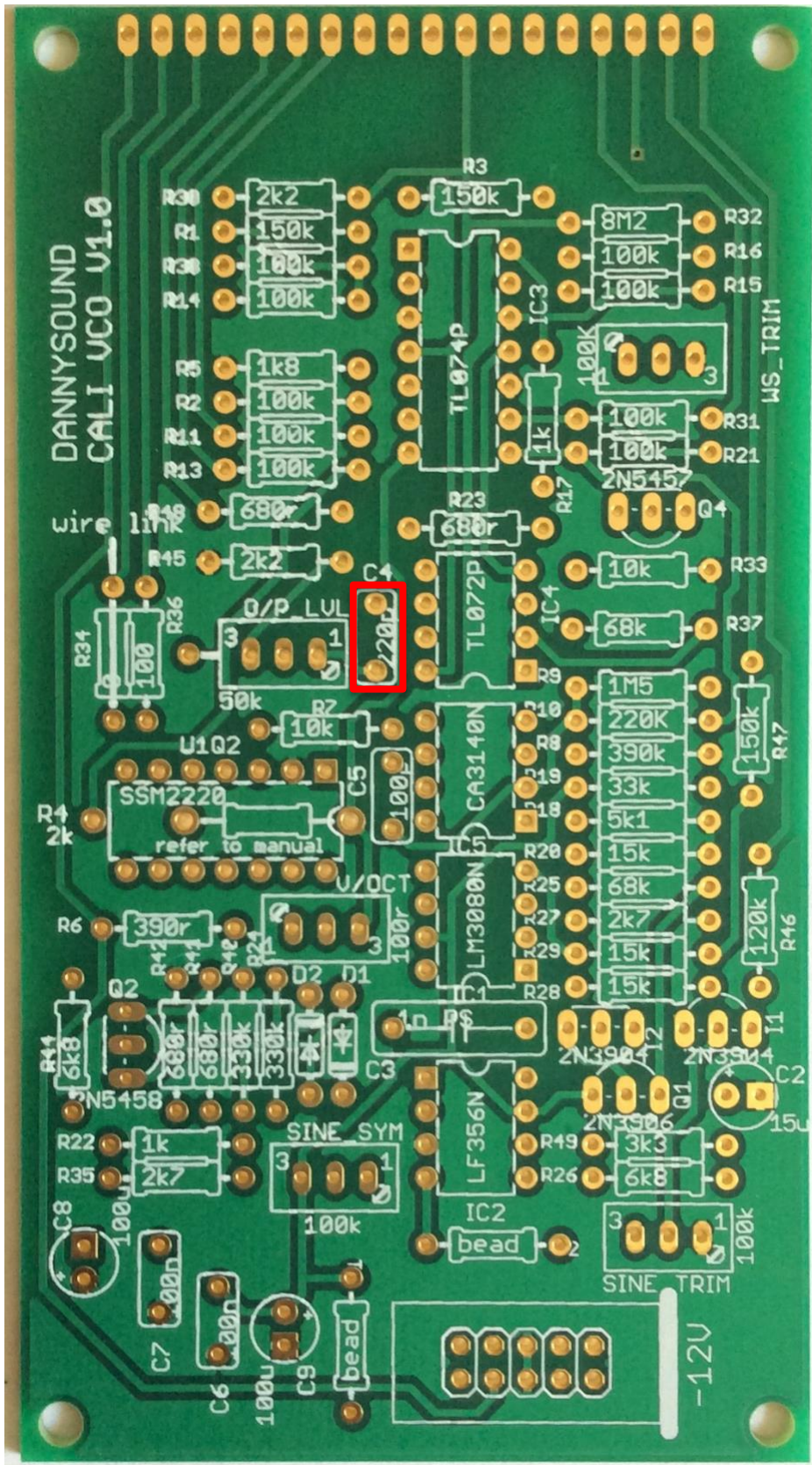

29 - 1 x 220pF capacitors (located in diode bag)

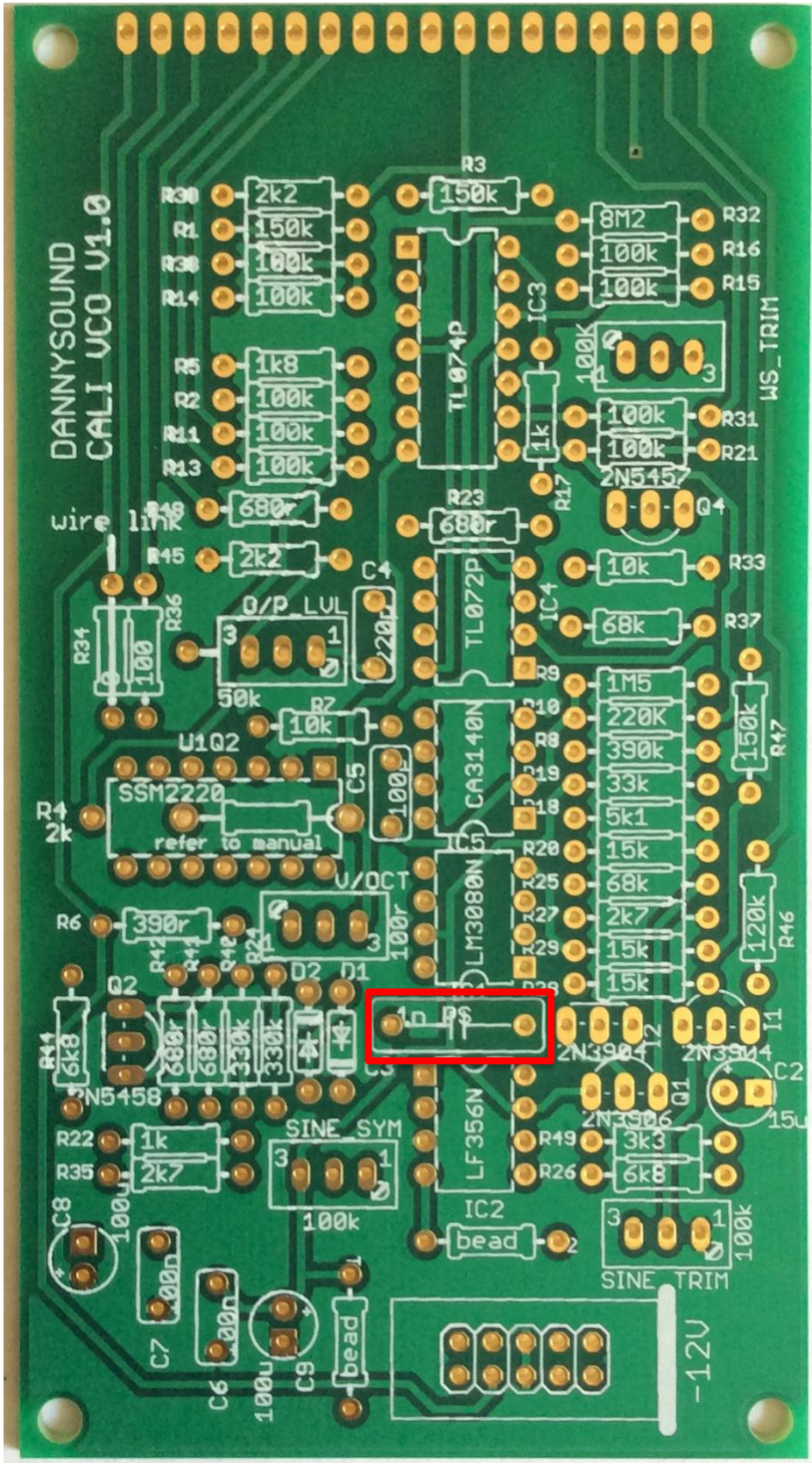

30 - 1 x 1nF capacitors

Transistors

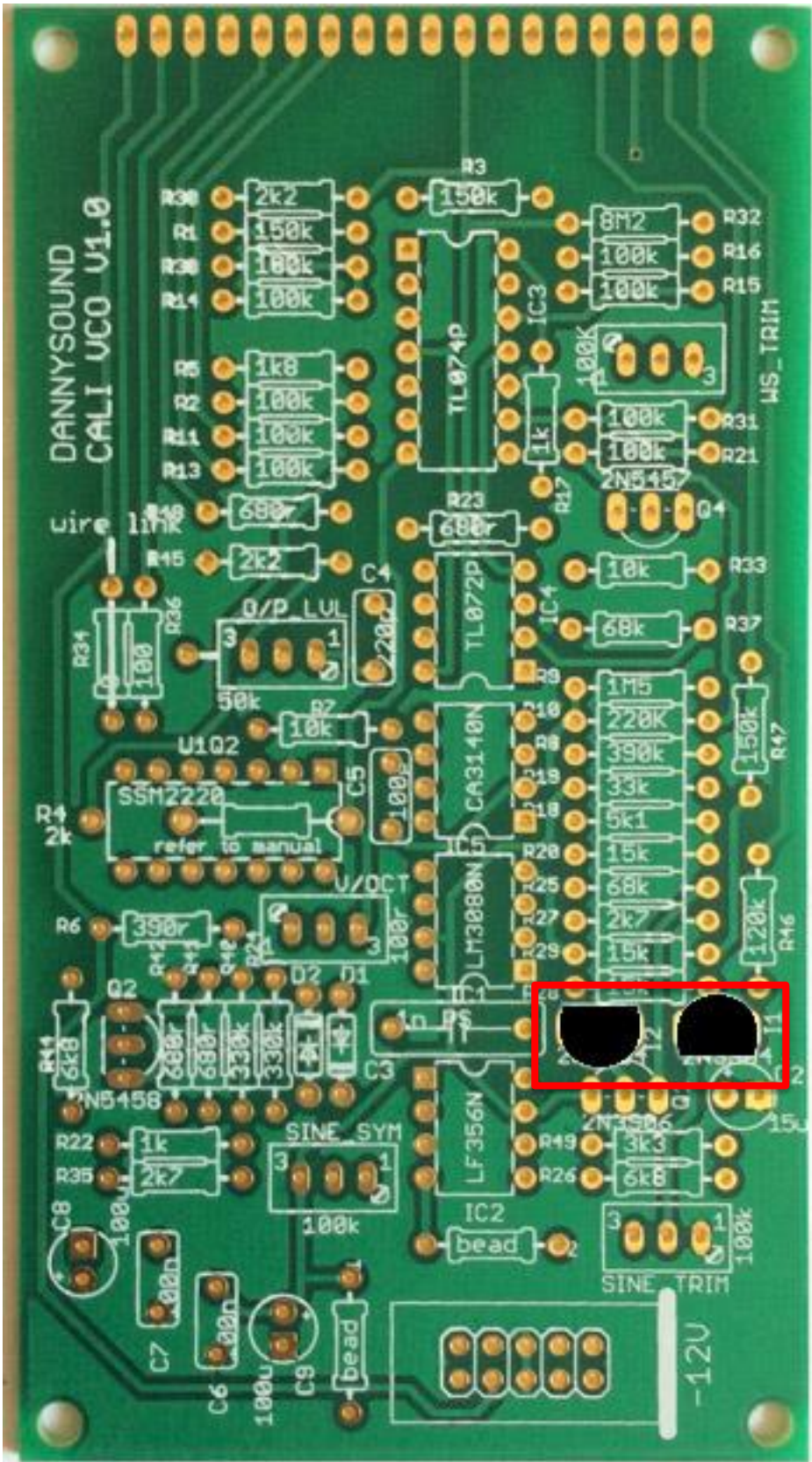

31 - 2 x 2N3904 transistors - Ensure the flat face on the component matches the flat face on the PCB silkscreen. Orientation is vital.

Be careful to individually identify all the transistors, there are many different types to separate, make sure what you have matches the label on the transistor bag.

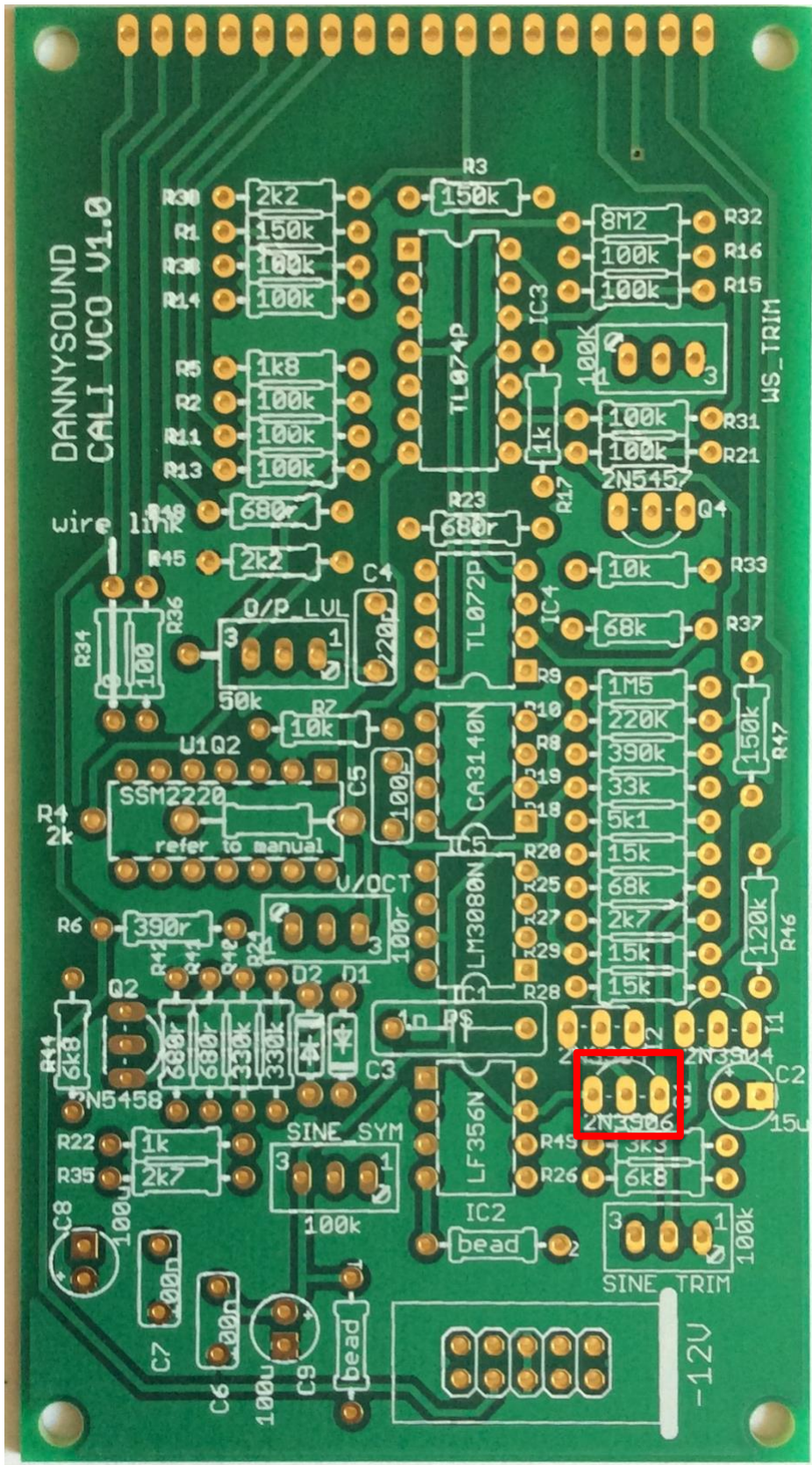

32 - 1 x 2N3906 transistors - Ensure the flat face on the component matches the flat face on the PCB silkscreen. Orientation is vital. **Use the single 2N3906 in the ESD bag - do not use the matched pair here.**

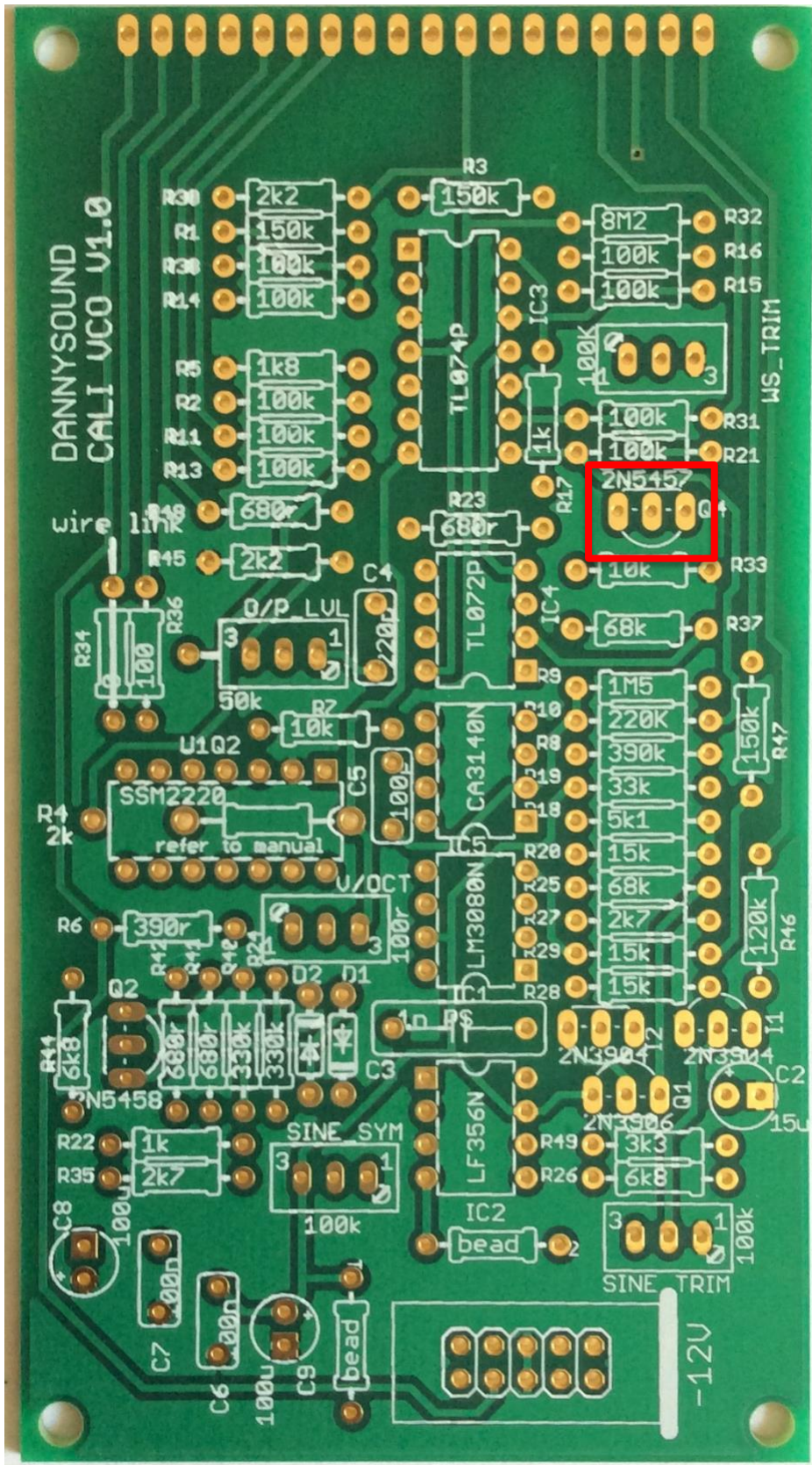

33 - 1 x 2N5457 transistors - Ensure the flat face on the component matches the flat face on the PCB silkscreen. Orientation is vital.

Be careful to individually identify all the transistors, there are many different types to separate, make sure what you have matches the label on the transistor bag.

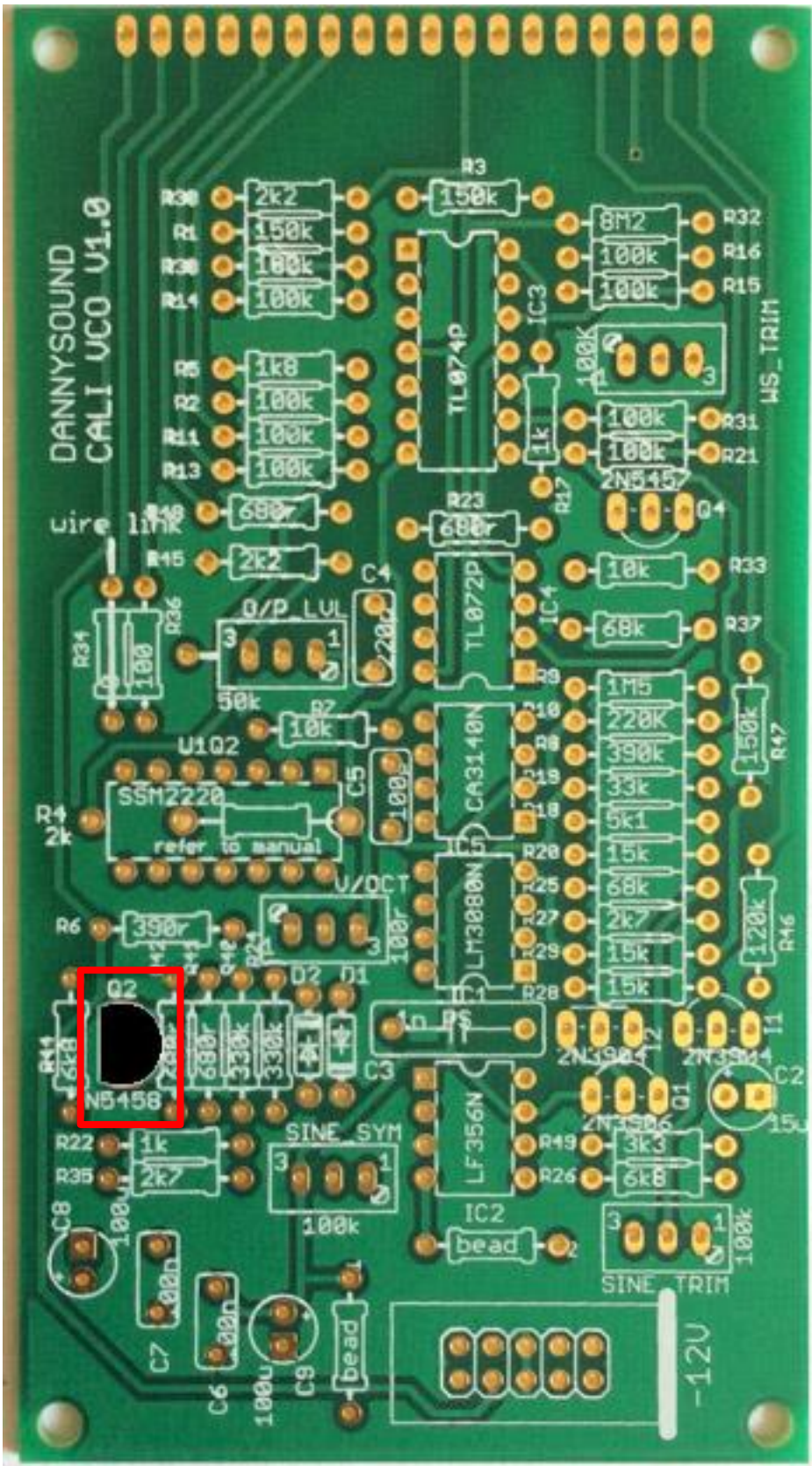

34 – 1 x 2N5458 selected transistor - Ensure the flat face on the component matches the flat face on the PCB silkscreen. Orientation is vital.

Power Socket

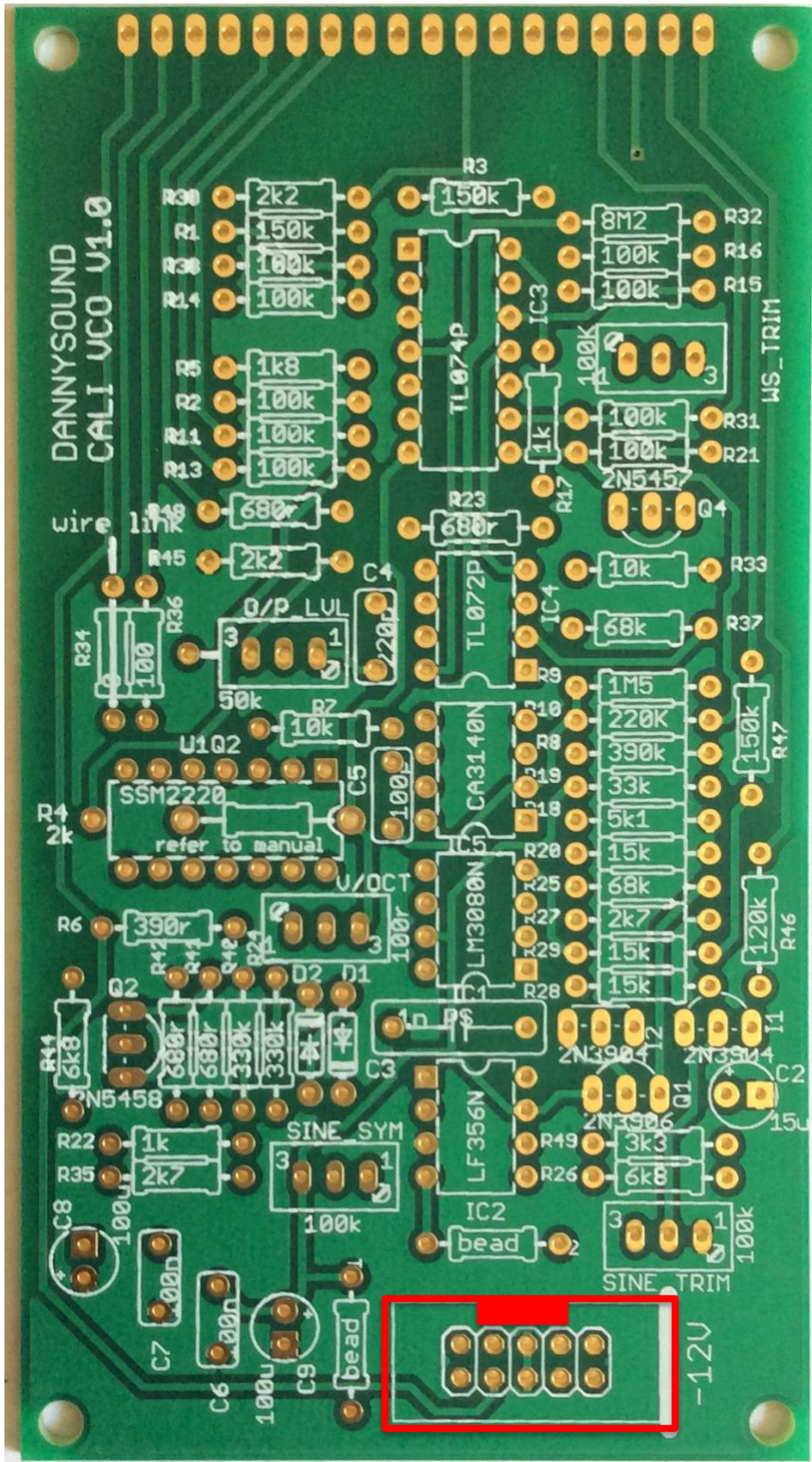

35 – 1 x power socket - **make sure the slot is facing away** from the edge of the PCB as indicated above. Orientation is vital!

Trim Pots

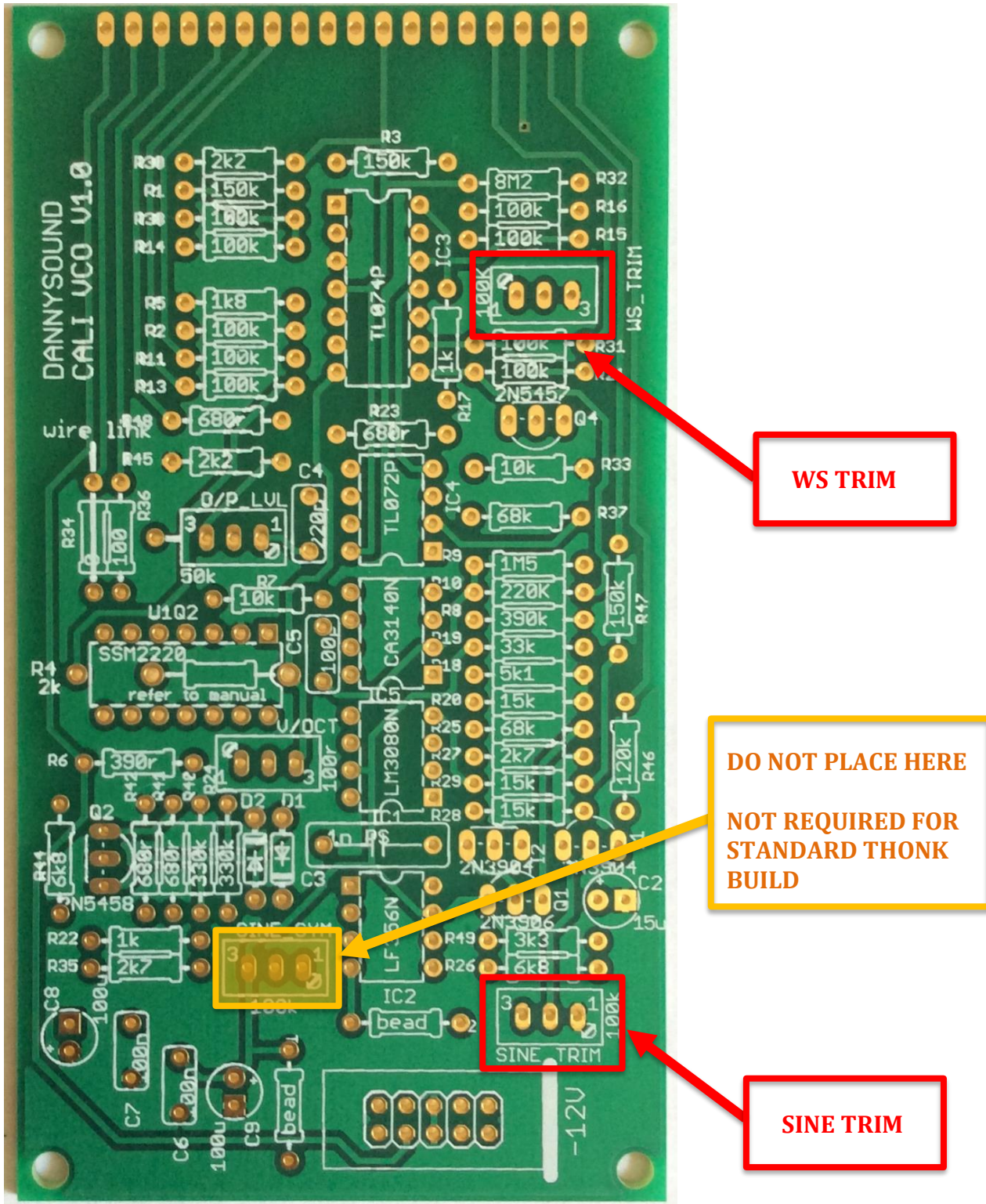

36 – 2 x 100k blue trimpots.

(The SINE SYM trimpot space is there as a precaution, it can be added if you have an oscilloscope and observe a dc offset in the sine wave. However this has not been needed in any of the modules tested so far and is not included in the Thonk kit.)

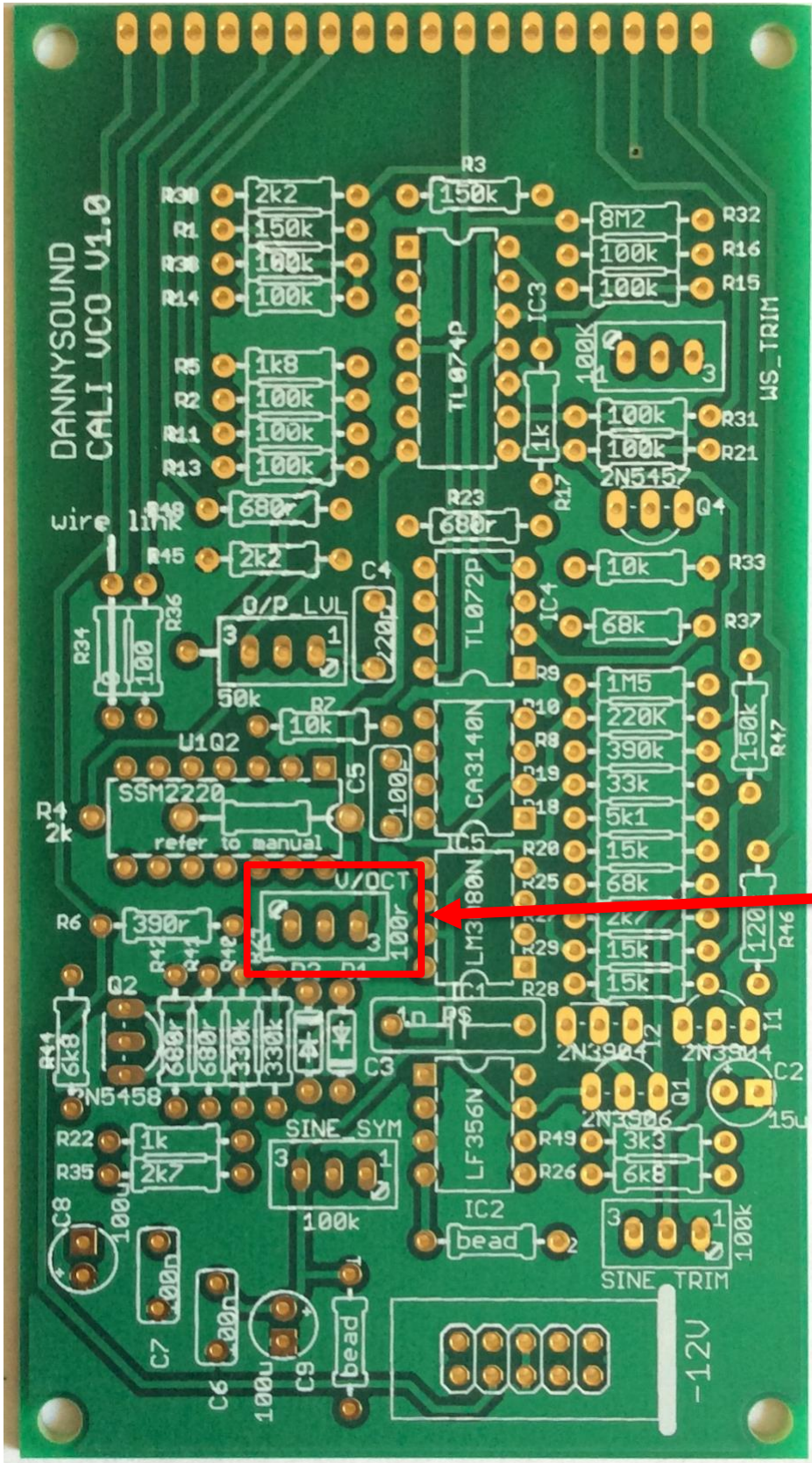

V/OCT

37 - 1 x 100r blue trimpot

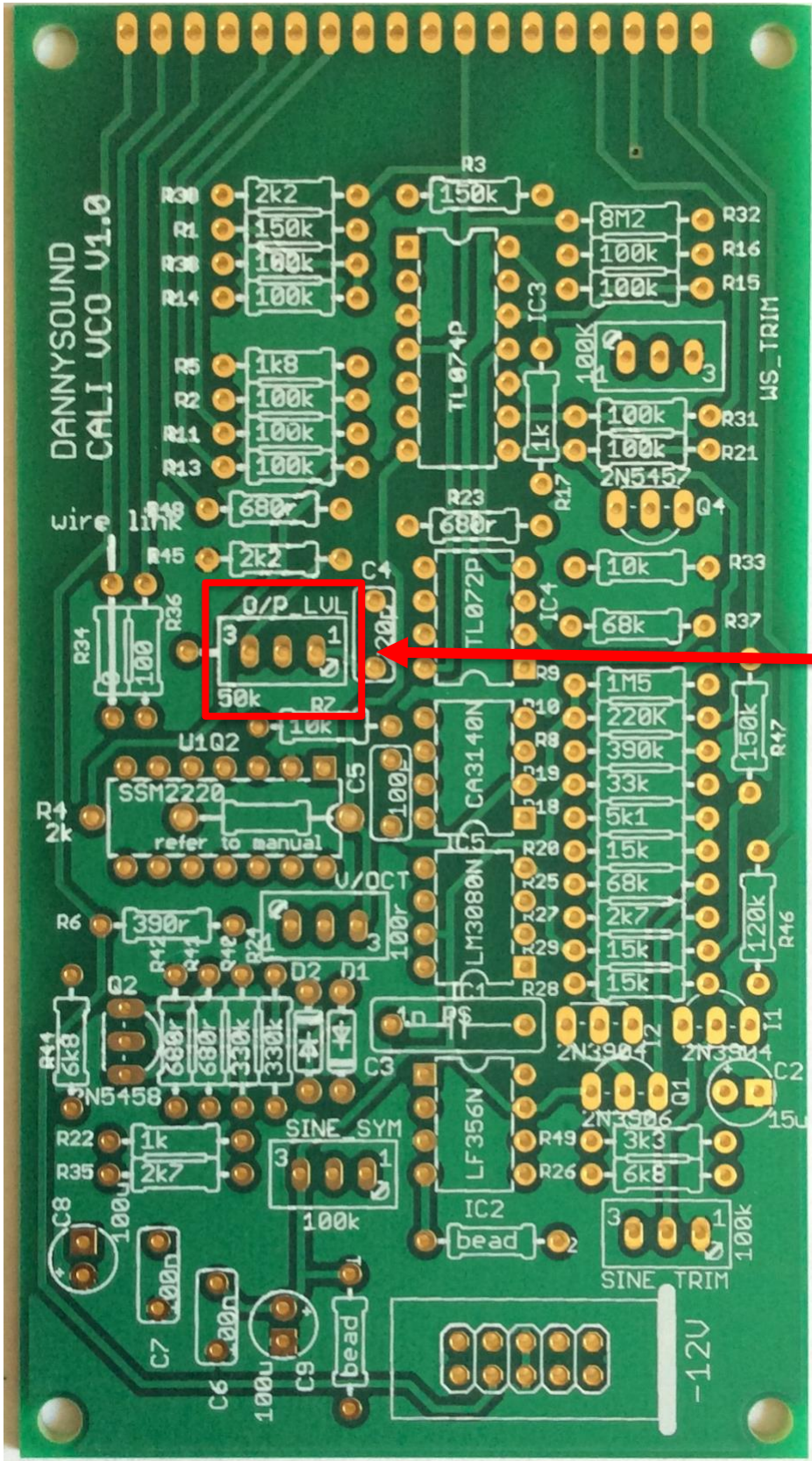

O/P LEVEL

38 - 1 x 50k blue trimpot

Electrolytic Capacitors

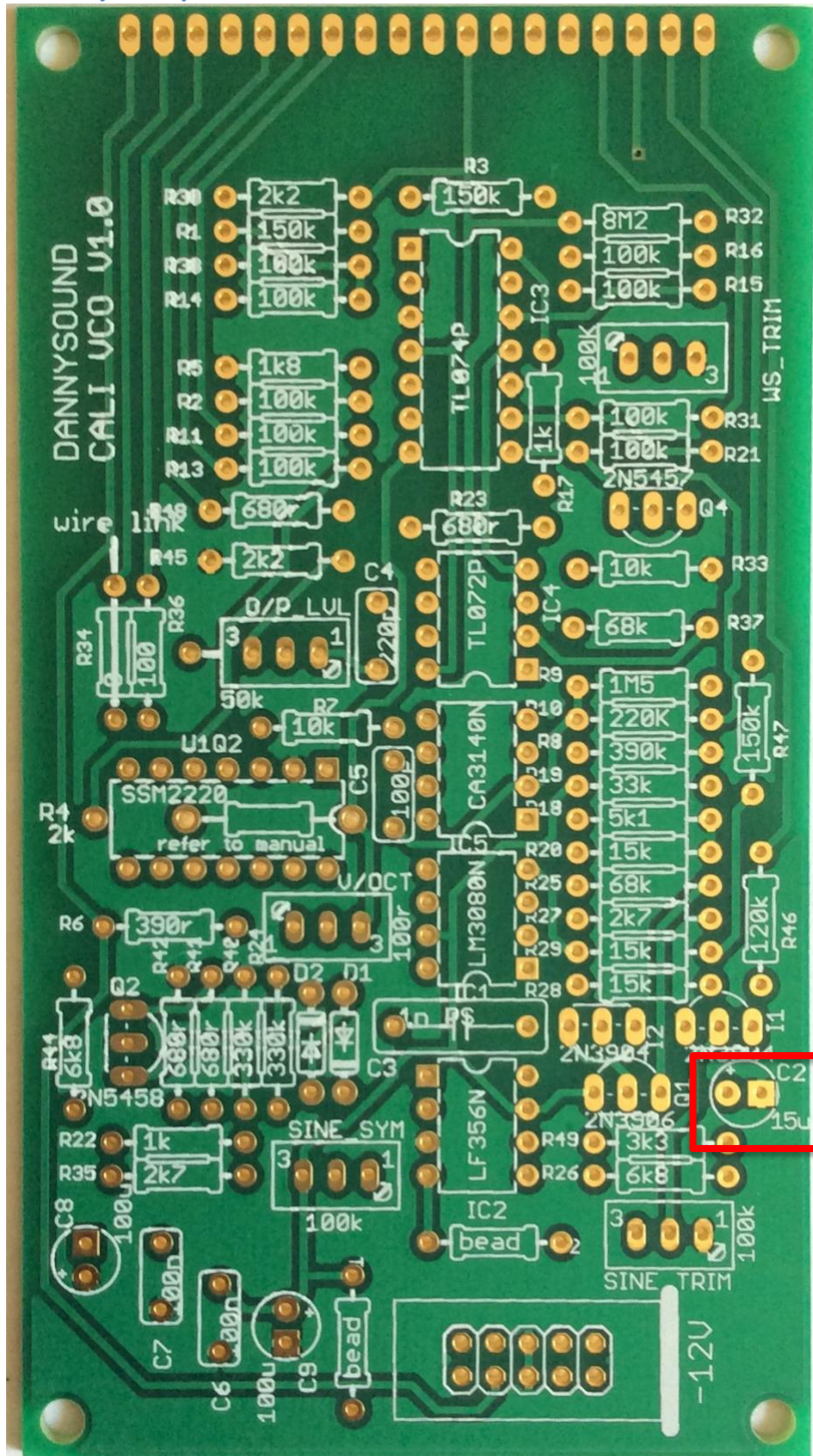

39 – 1 x 15µF capacitor - orientation is vital, the longer lead on the component should go to the circular pad marked with a plus '+' on the PCB. Note the component has a grey stripe on the cylindrical body on the minus side.

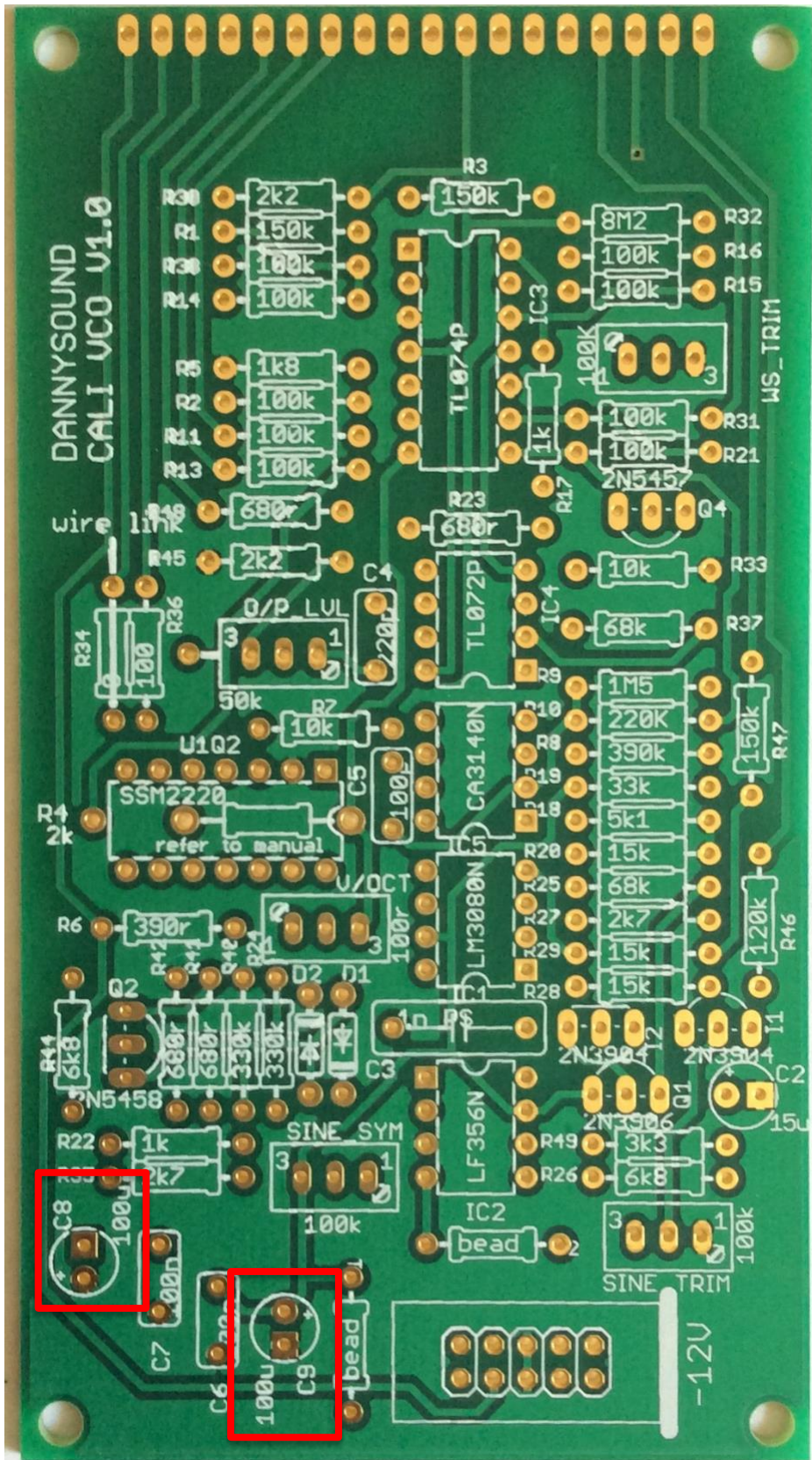

40 – 2 x **100µF** capacitors - orientation is vital, the longer lead on the component should go to the circular pad marked with a plus '+' on the PCB. Note the component has a grey stripe on the cylindrical body on the minus side.

Note: Do not confuse with 10uf caps – 100uf capacitors are located in the diode bag

Board Connector

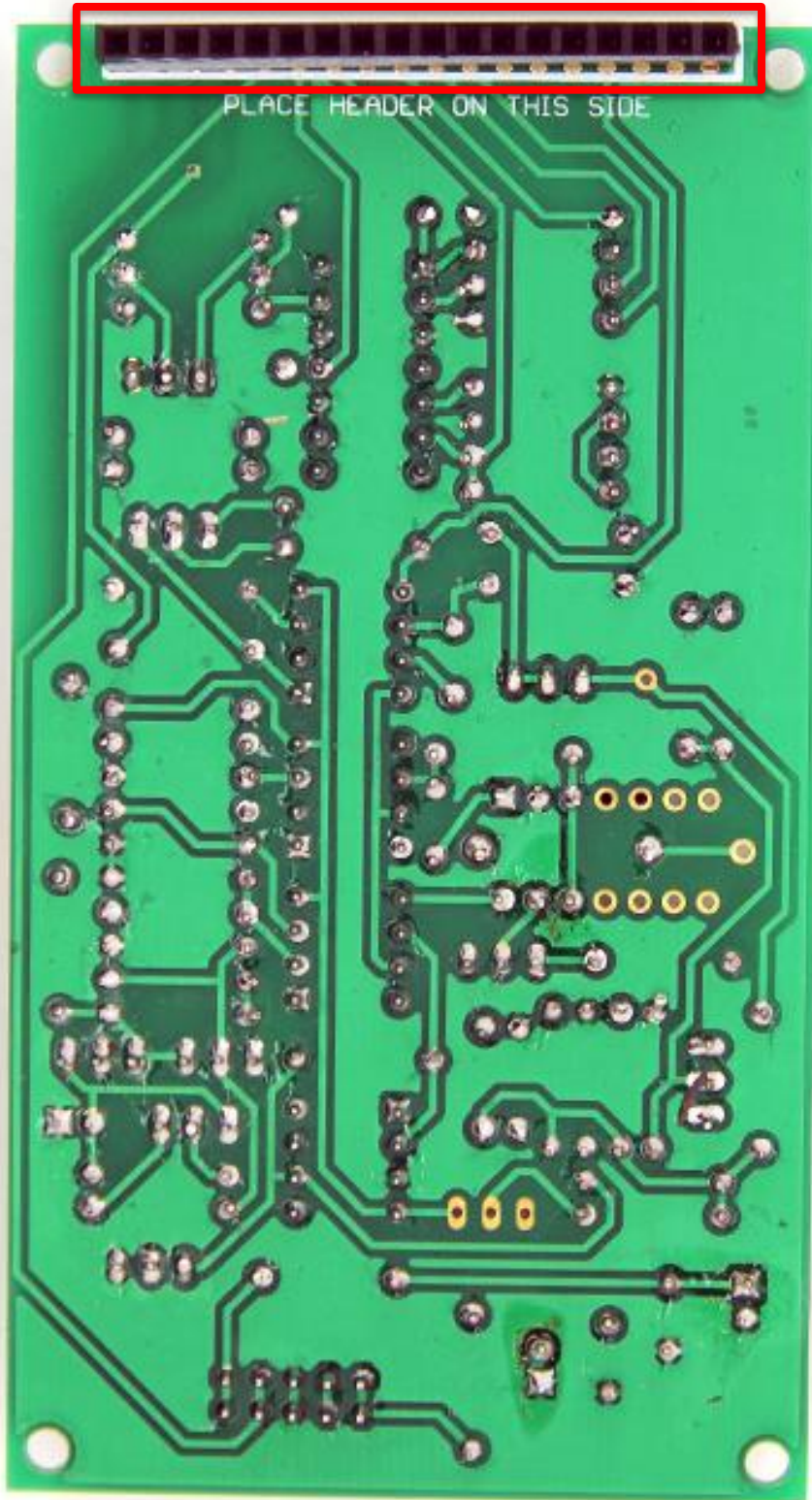

41 - 18 pin female connector

Section 2 – Power Test, Matched Transistors and IC placement

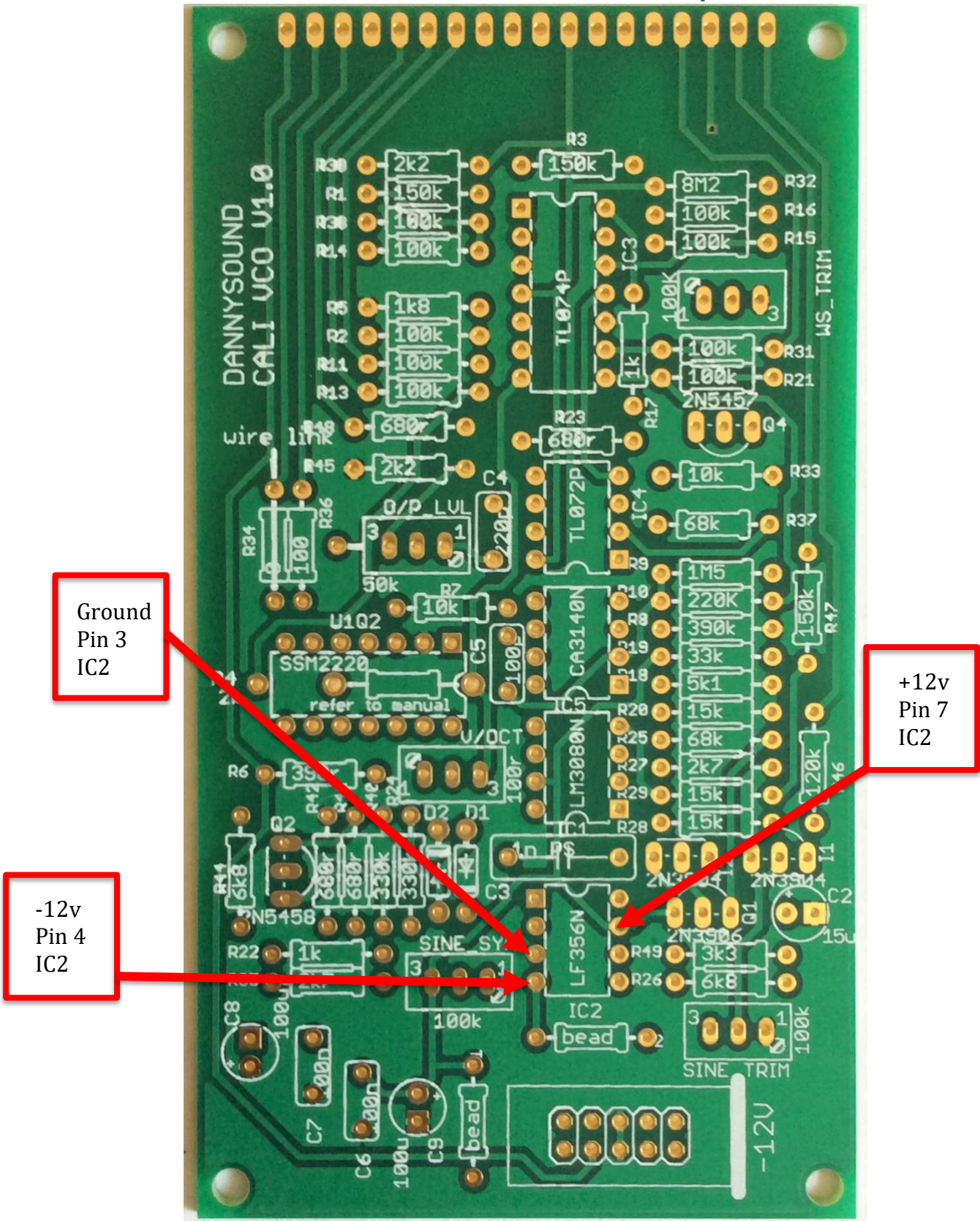

1 – test power

Take note of transistor orientation. Place transistors as close together as possible.

Socket is not needed if using matched 2N3906s

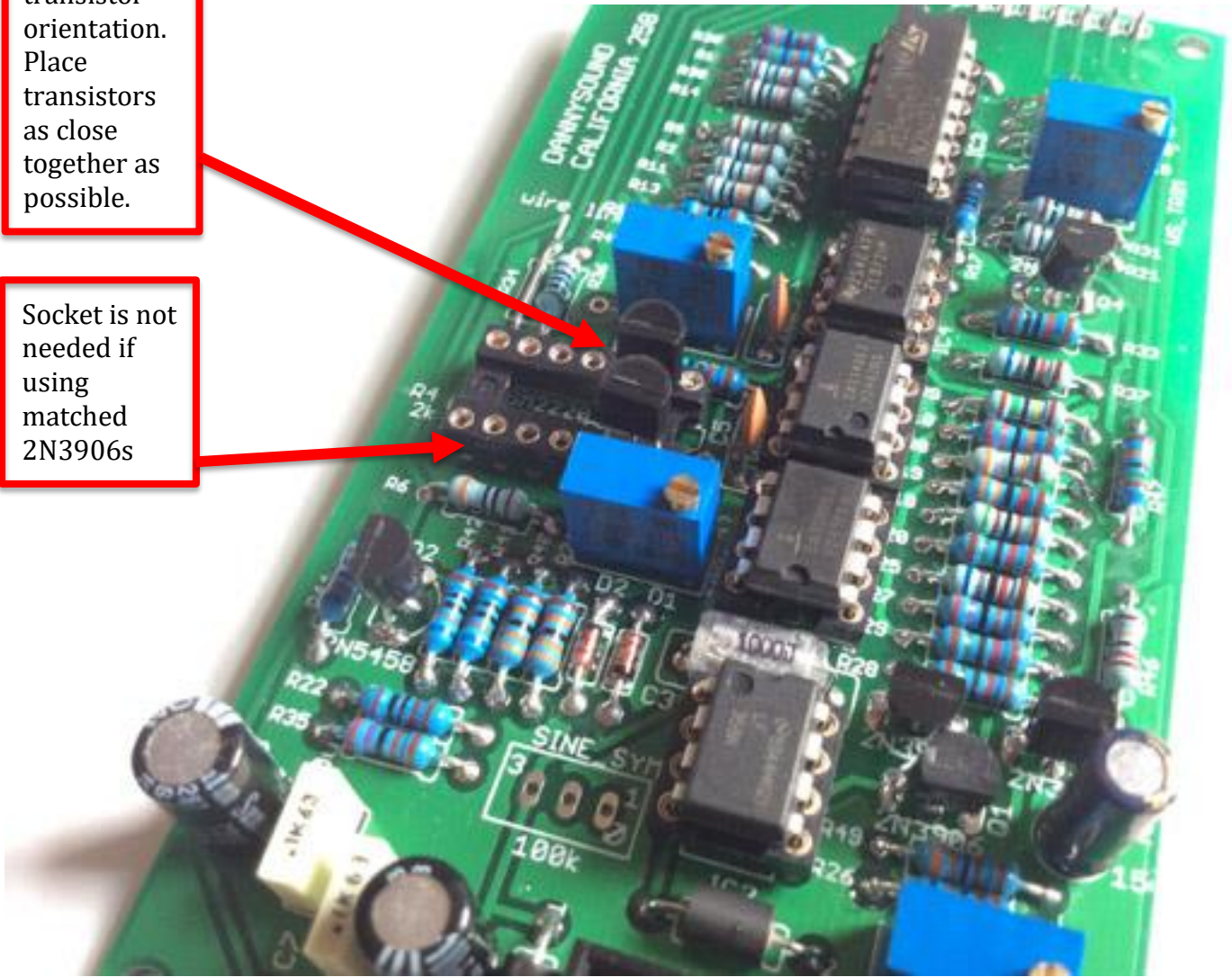

2 - 1 x matched pair of 2N3906s - both transistors have their flat edge facing towards the power header. Orientation is vital.

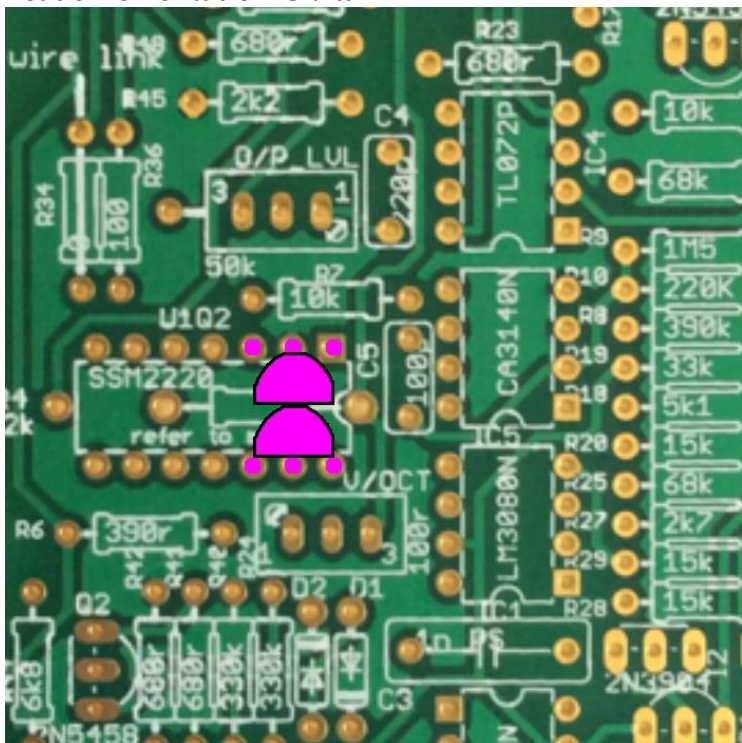

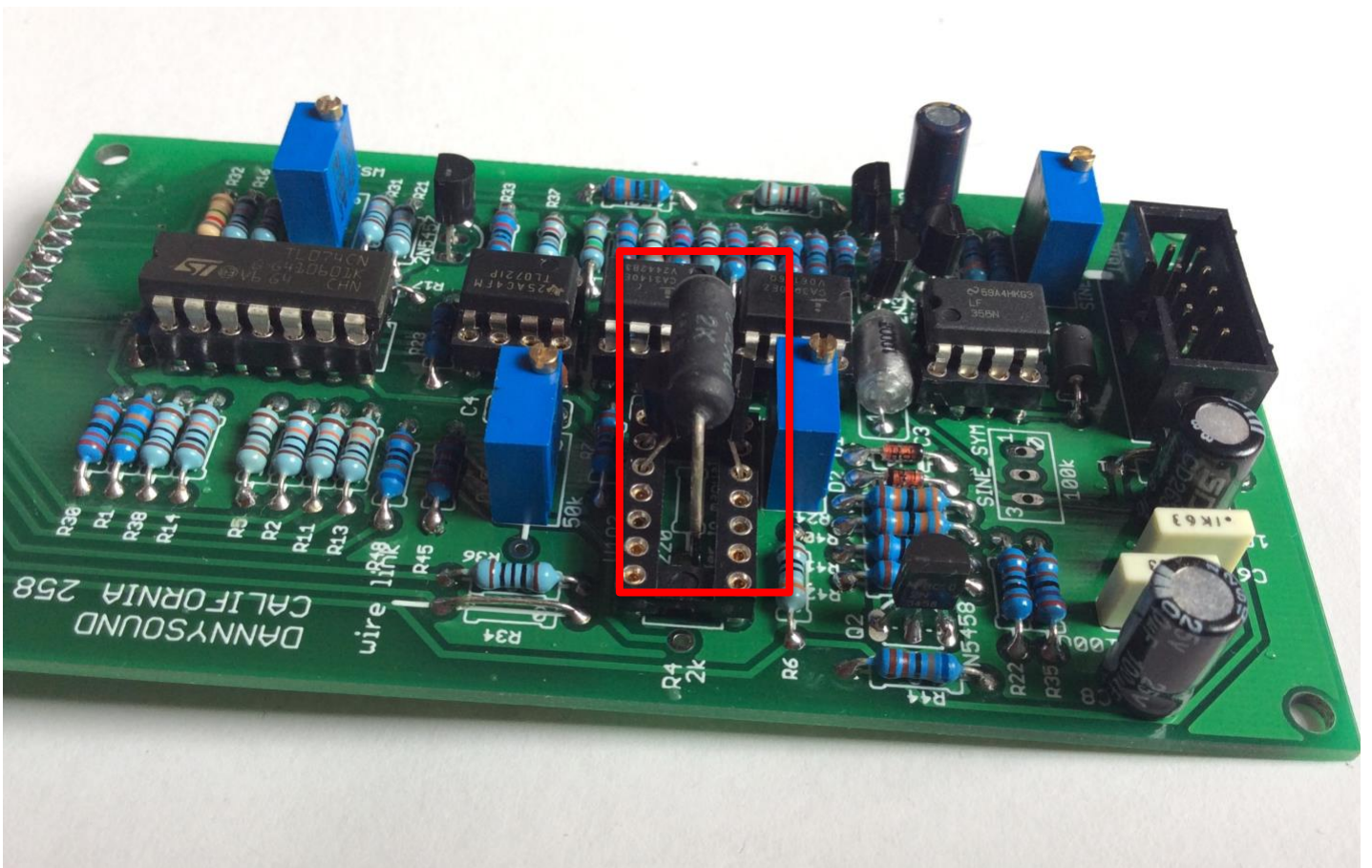

3 - 1 x 2k TEMPCO resistor - solder the tempco so that it's touching the matched pair below it

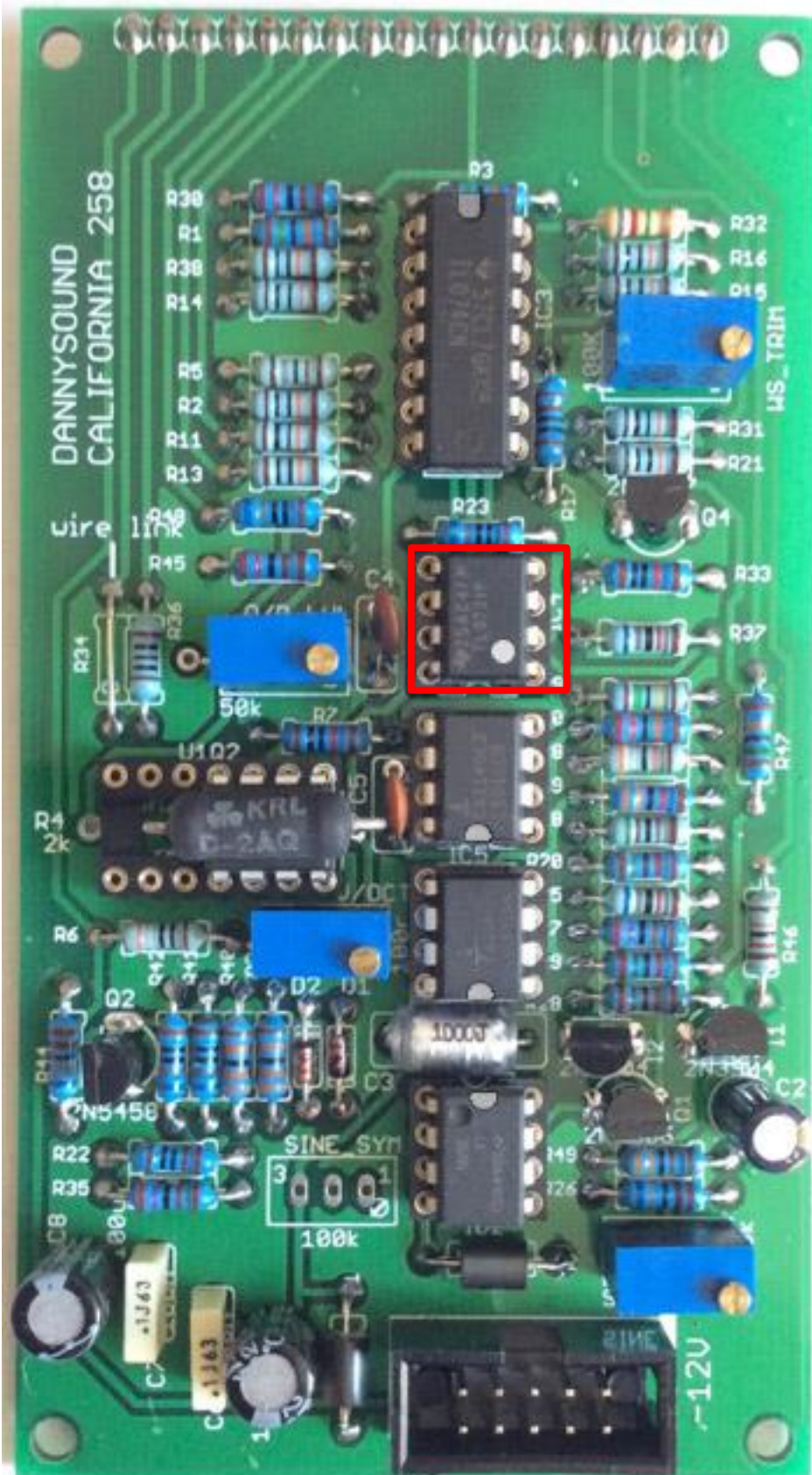

4 - 1 x TL072 opamp - orientation is vital, for these opamps match the dot with the notch on the PCB silkscreen and IC Socket

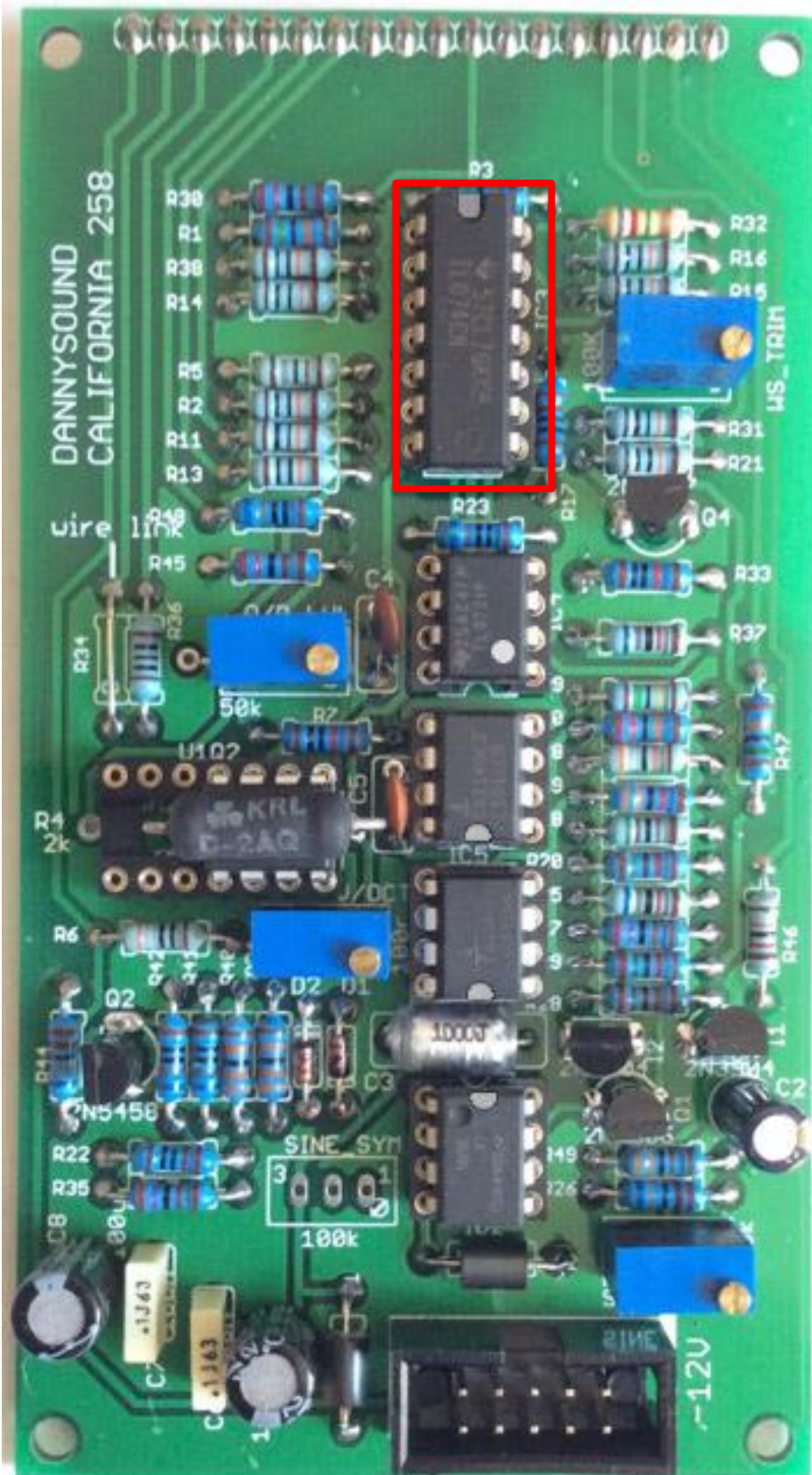

5 - 1 x TL074 opamp - match the notch on the chip with the notch on the PCB silkscreen and IC Socket - orientation is vital.

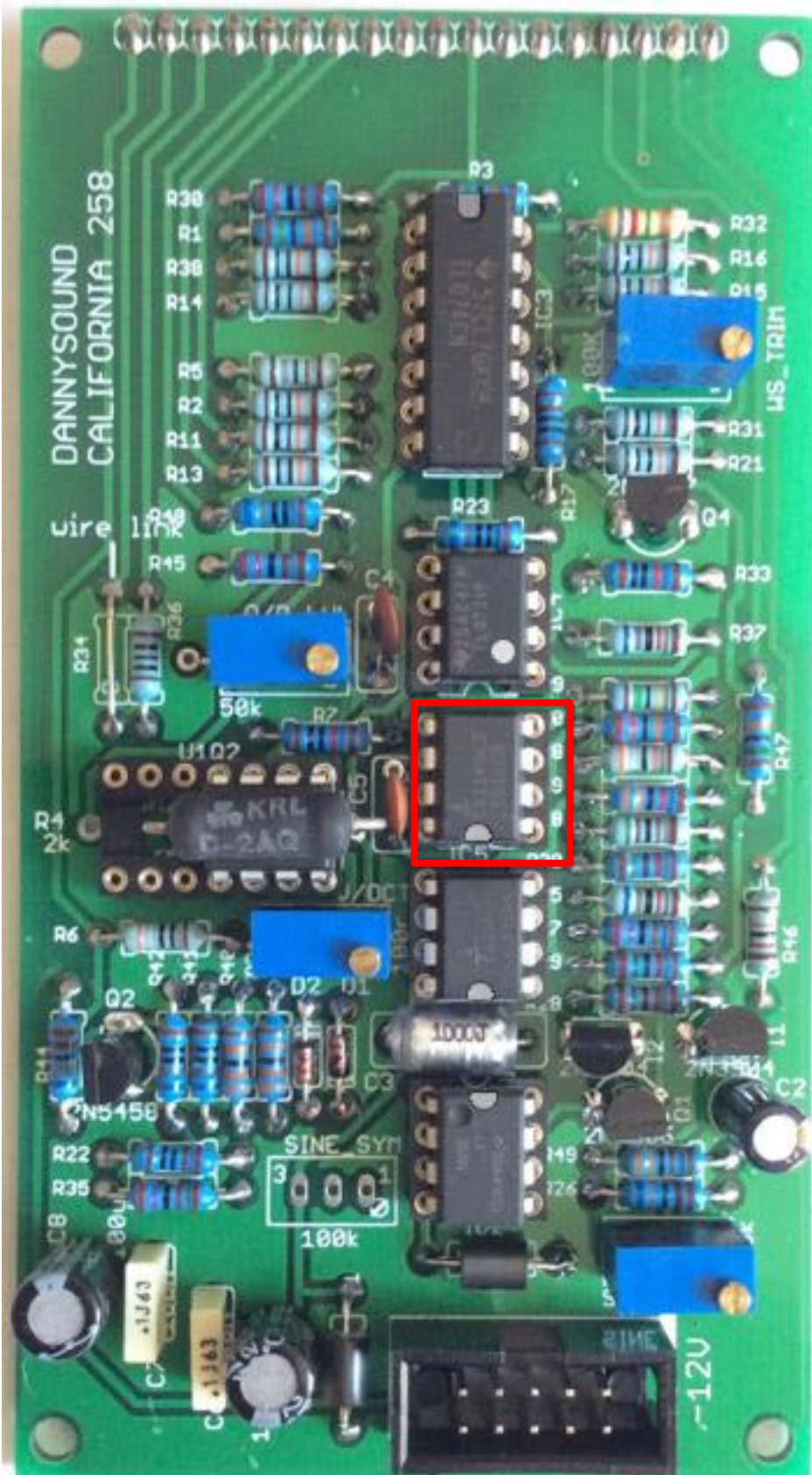

6 - 1 x CA3140 opamp - match the notch on the chip with the notch on the PCB silkscreen and IC Socket - orientation is vital.

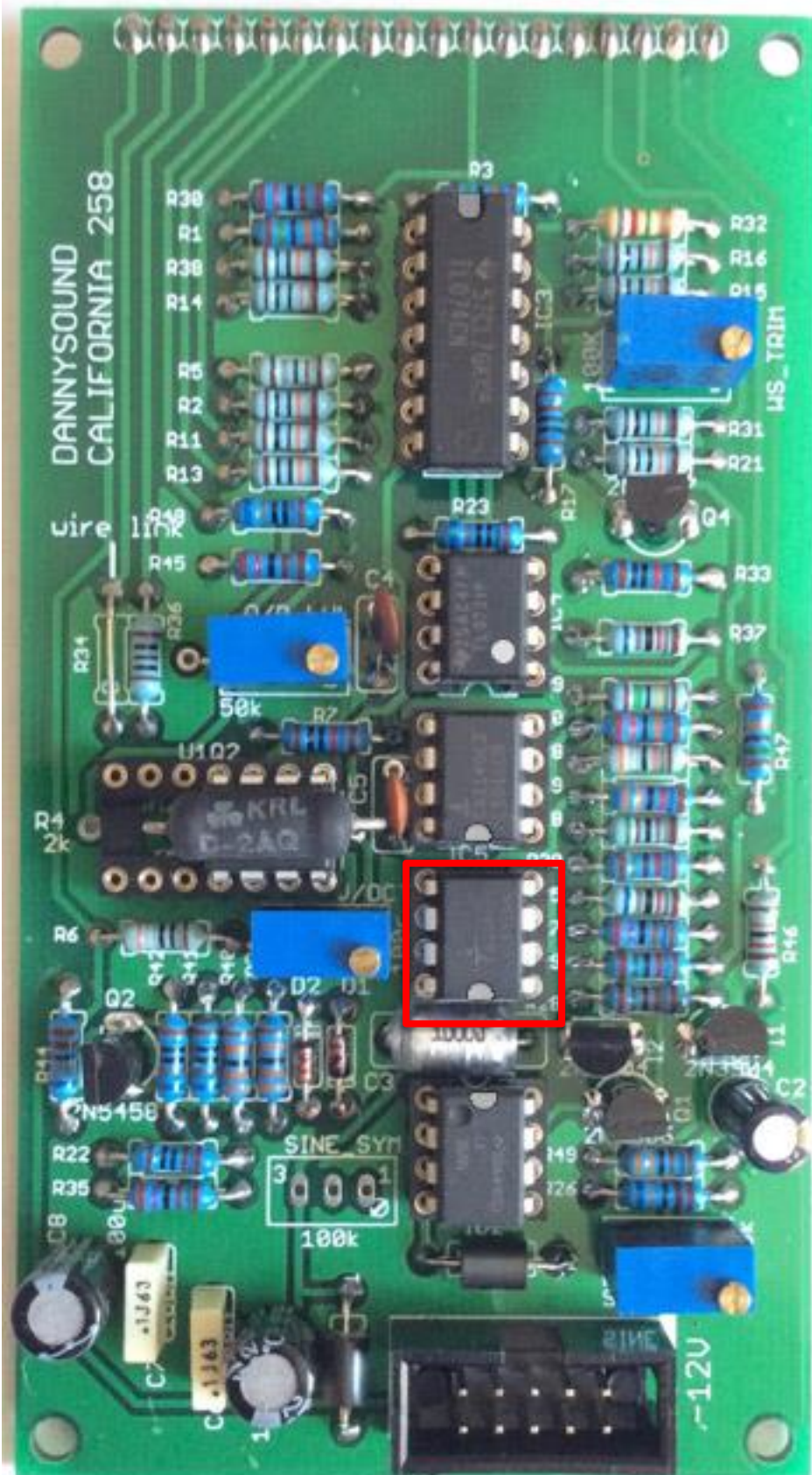

7 - 1 x CA3080 opamp - match the notch on the chip with the notch on the PCB silkscreen and IC Socket - orientation is vital.

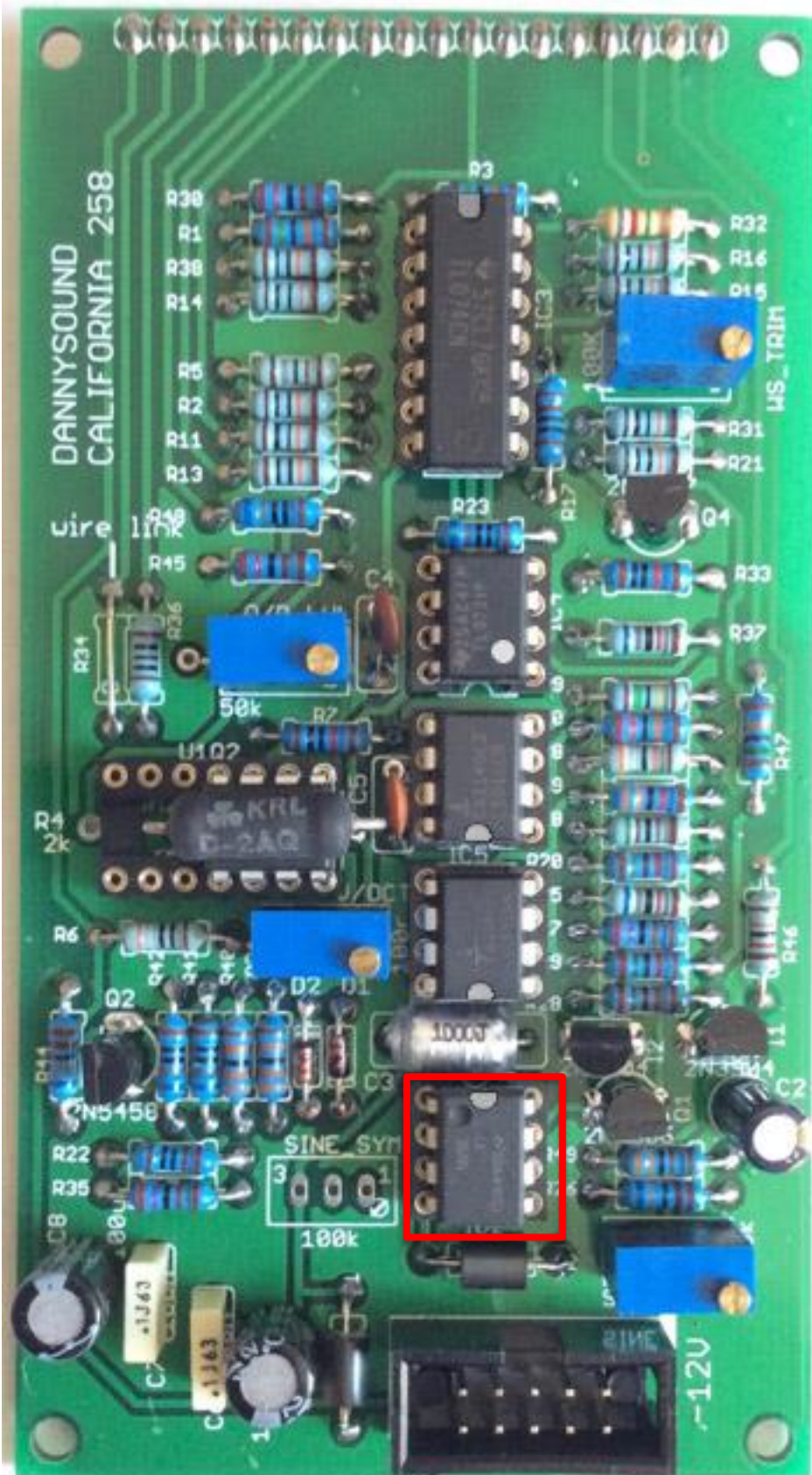

8 - 1 x LF356 opamp - match the notch on the chip with the notch on the PCB silkscreen and IC Socket - orientation is vital.

Section 3 – Pots PCB

Resistors

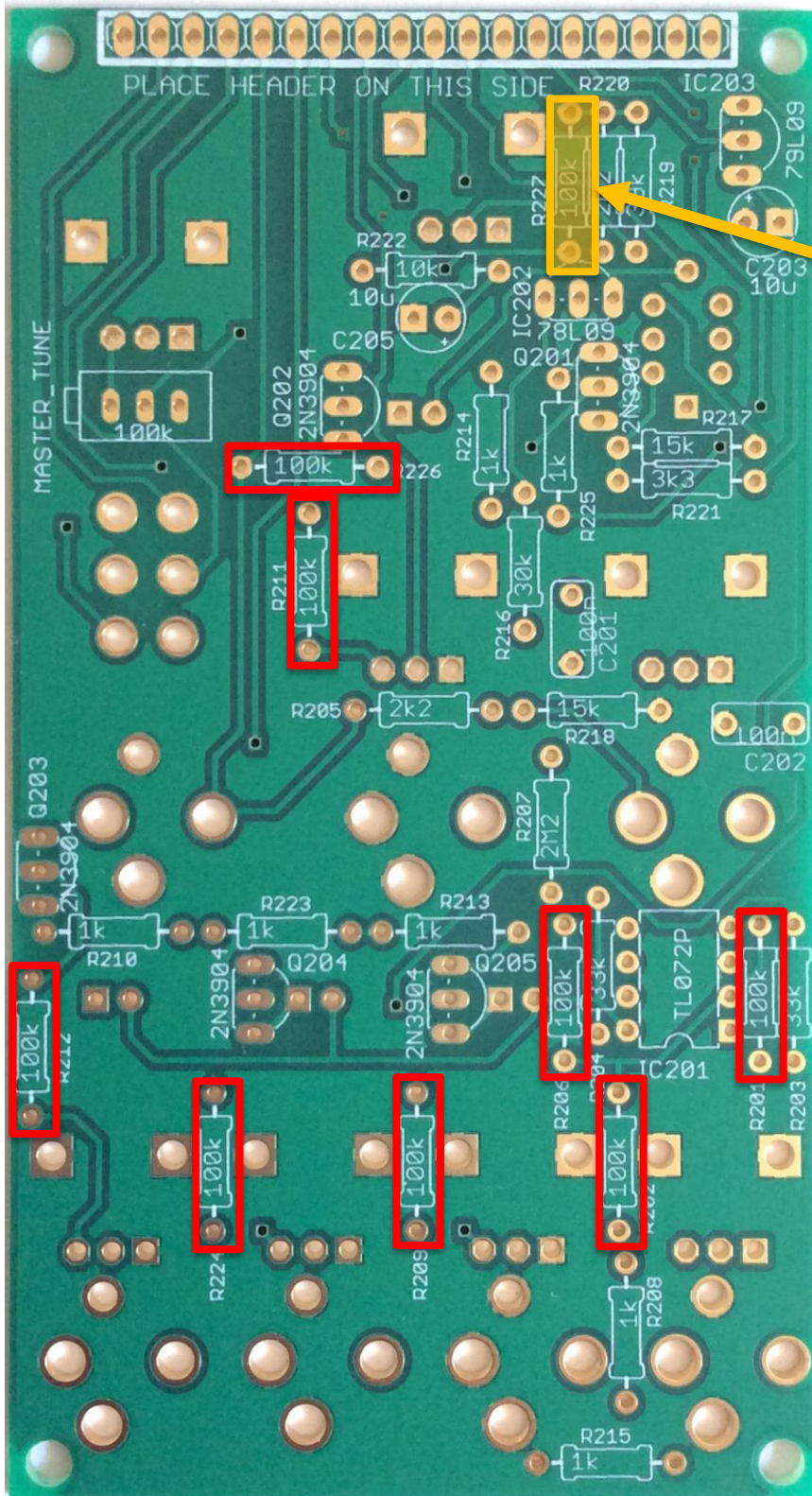

1 - 8 x 100k resistors

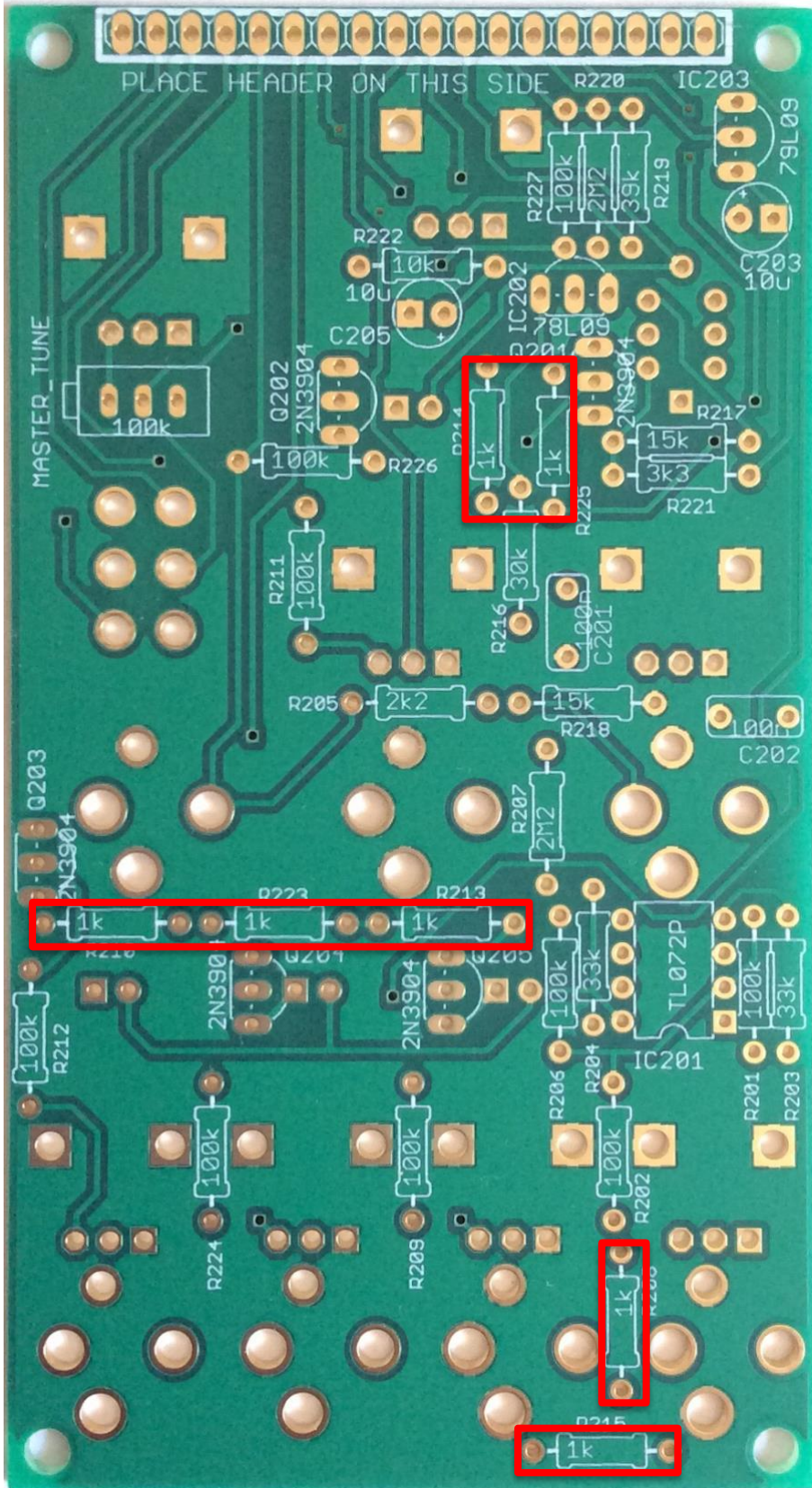

2 - 7 x 1k resistors

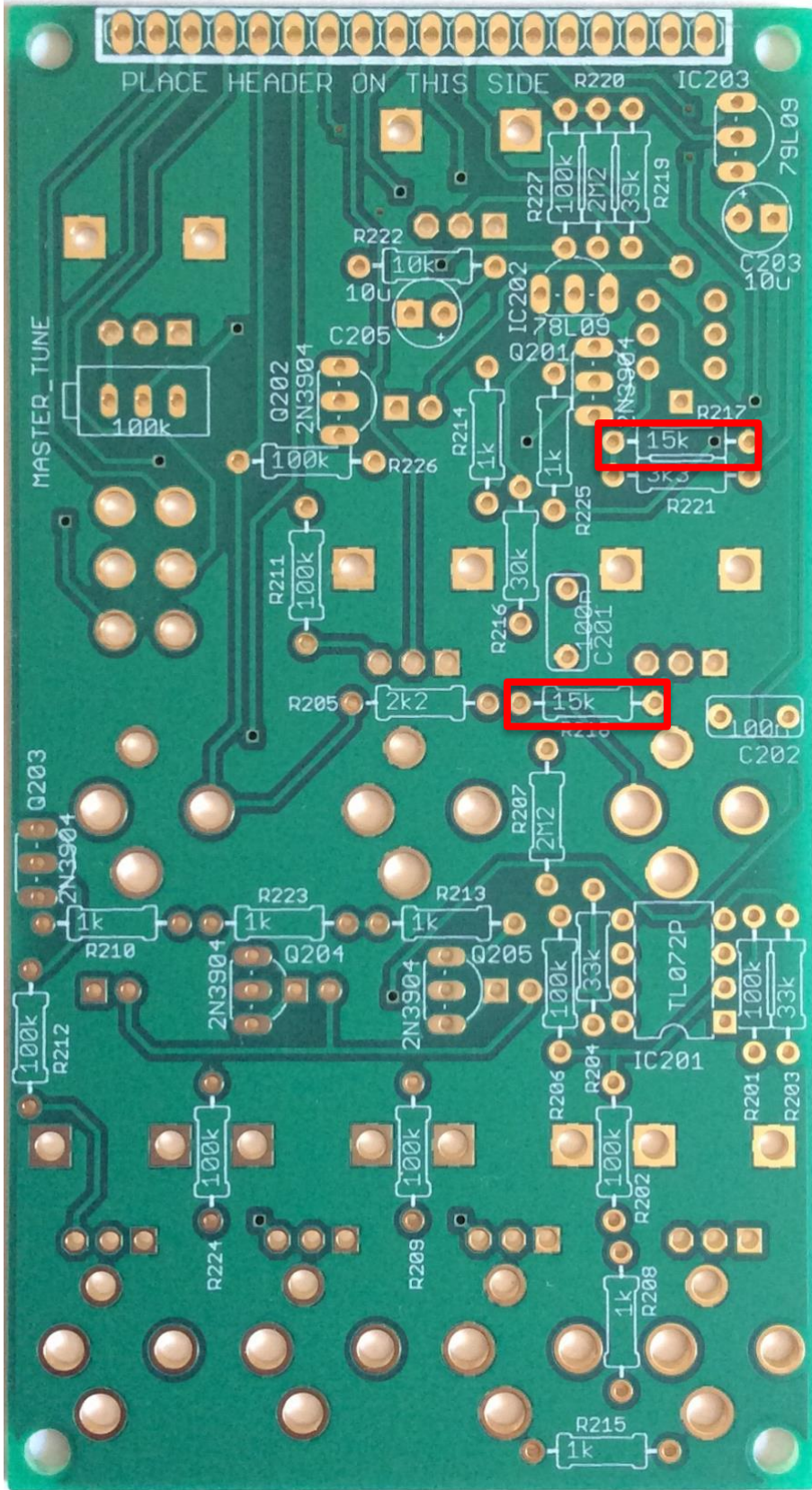

3 - 2 x 15k resistors

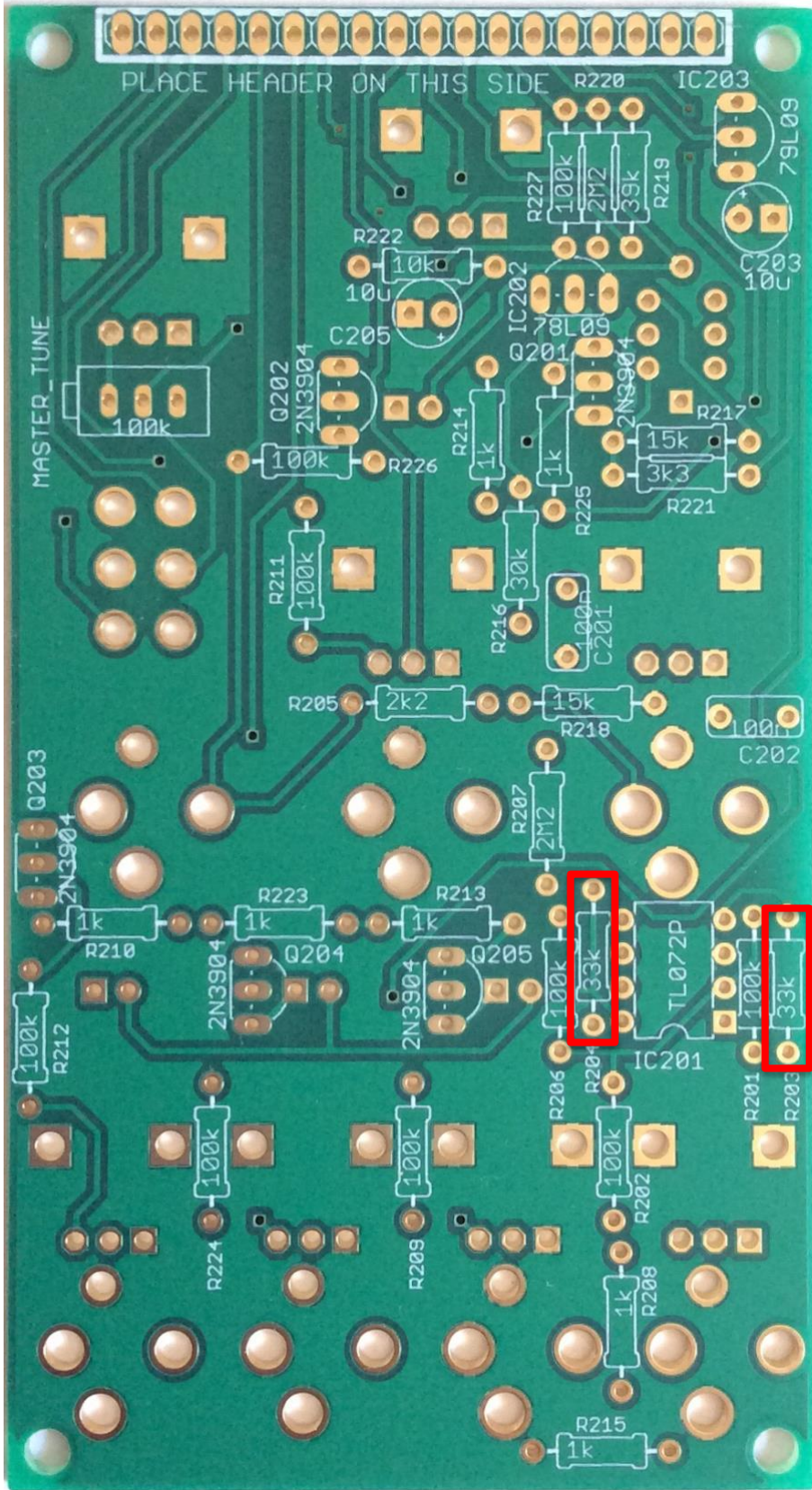

4 - 2 x 33k resistors

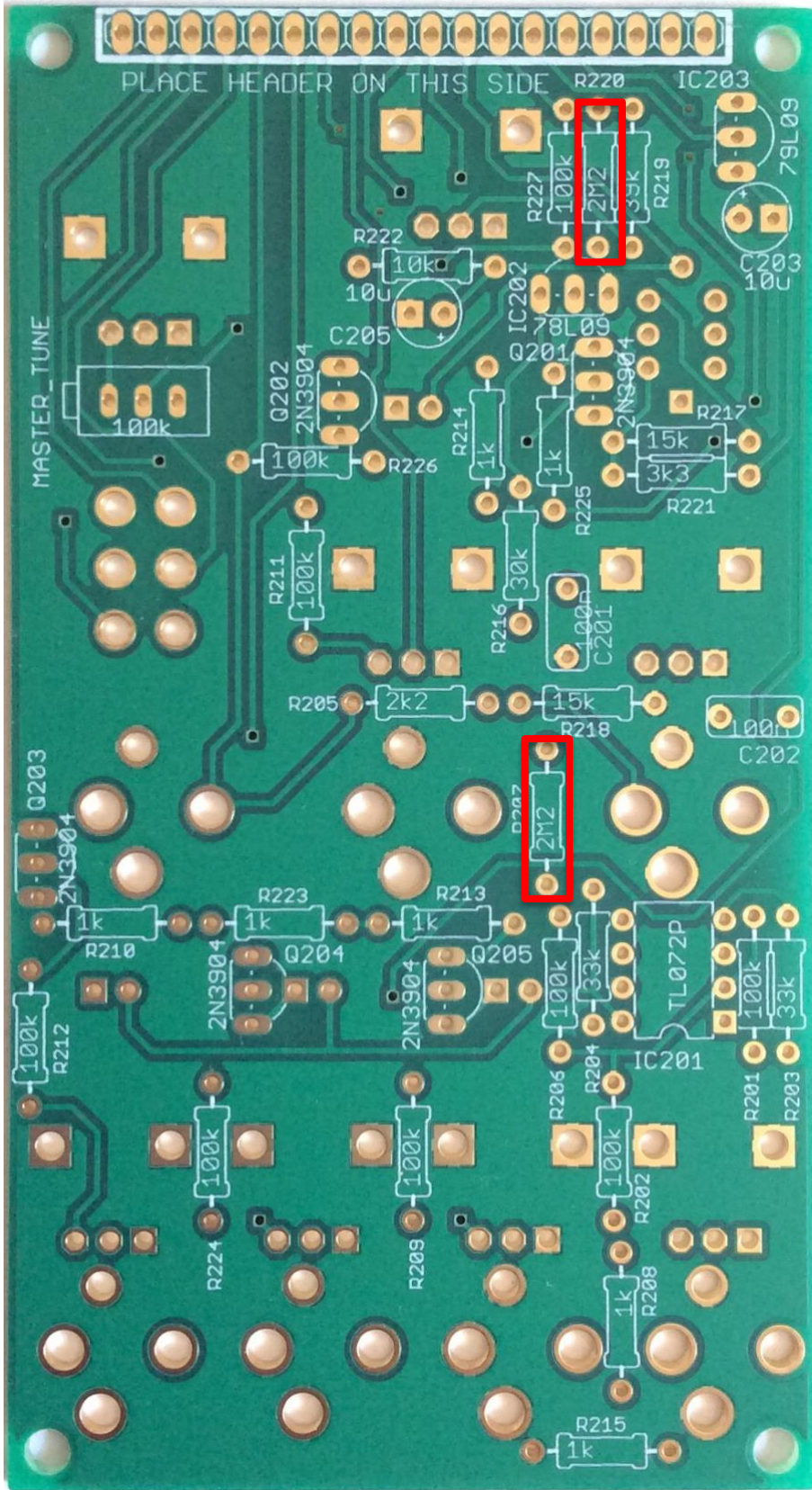

5 - 2 x 2M2 resistors

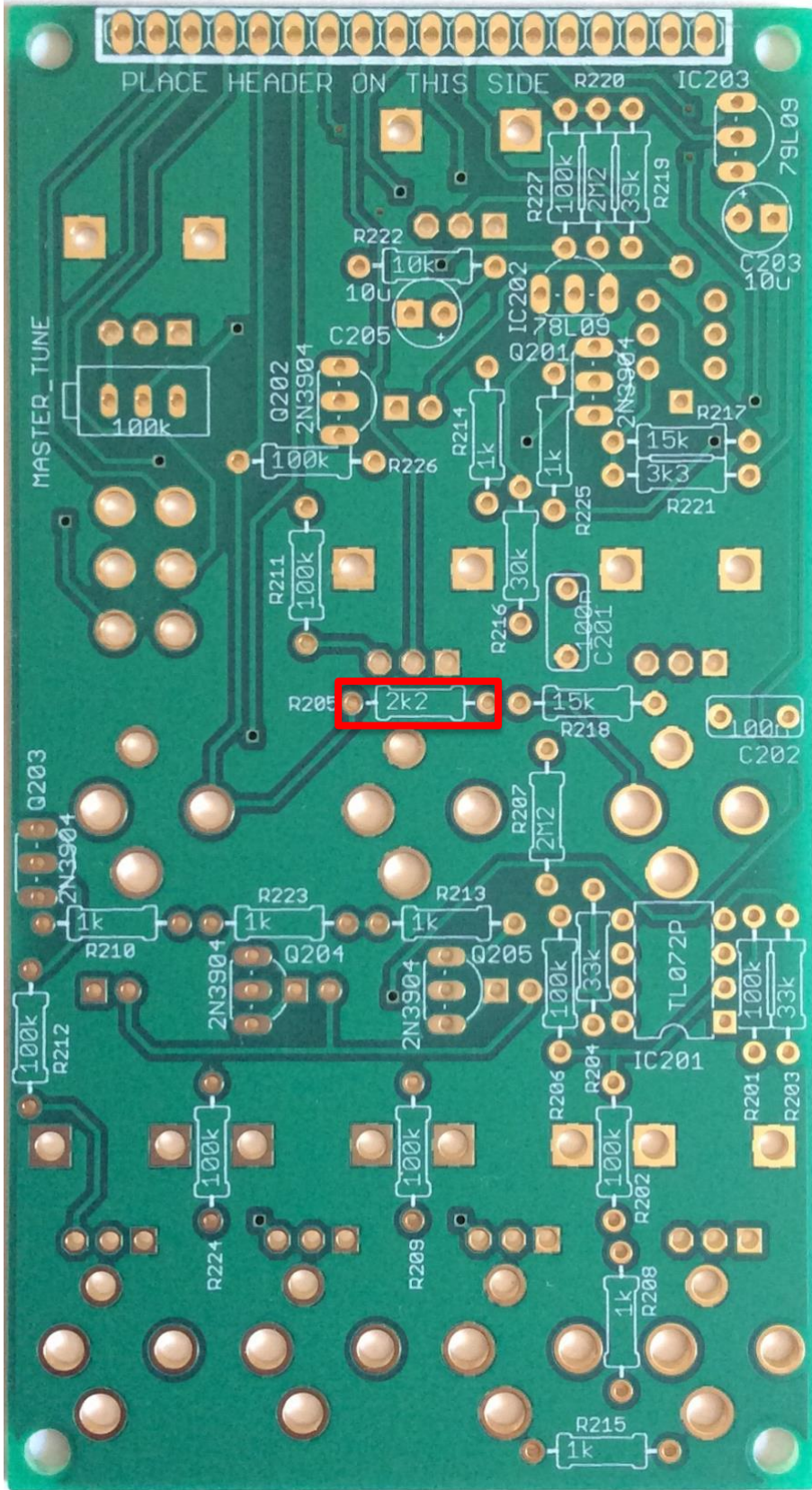

6 - 1 x 2k2 resistors

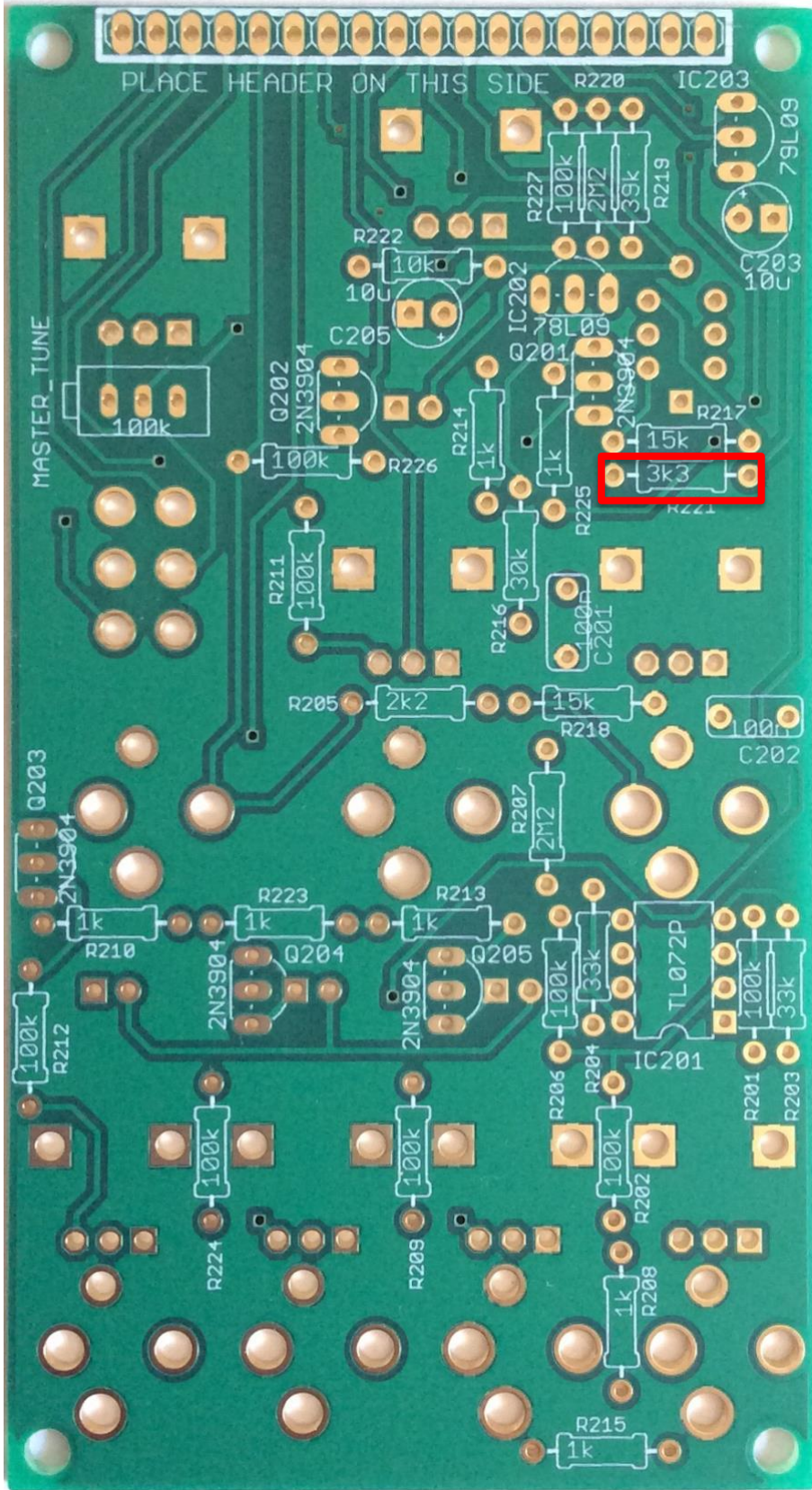

7 - 1 x 3k3 resistors

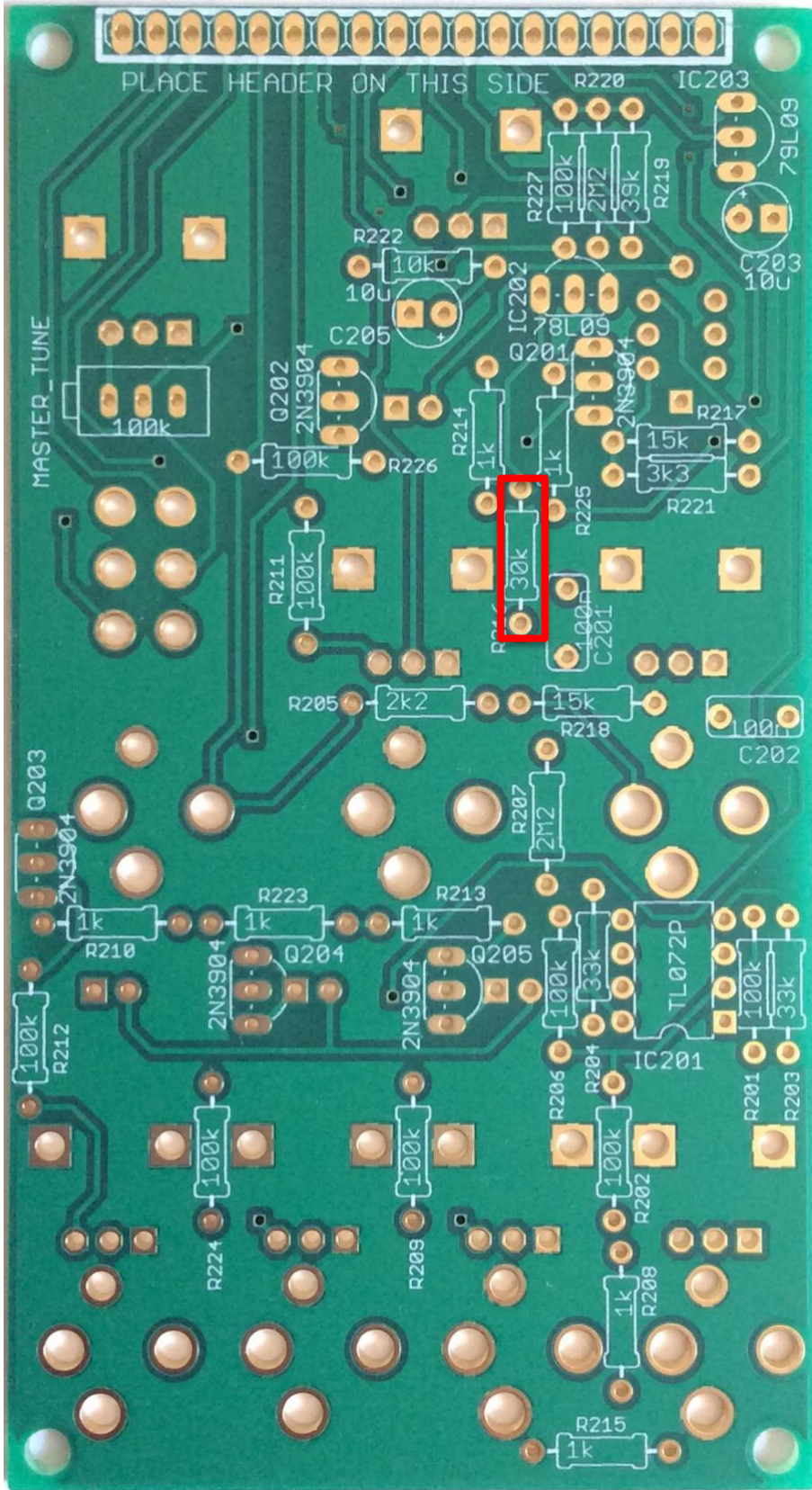

8 - 1 x 30k resistors

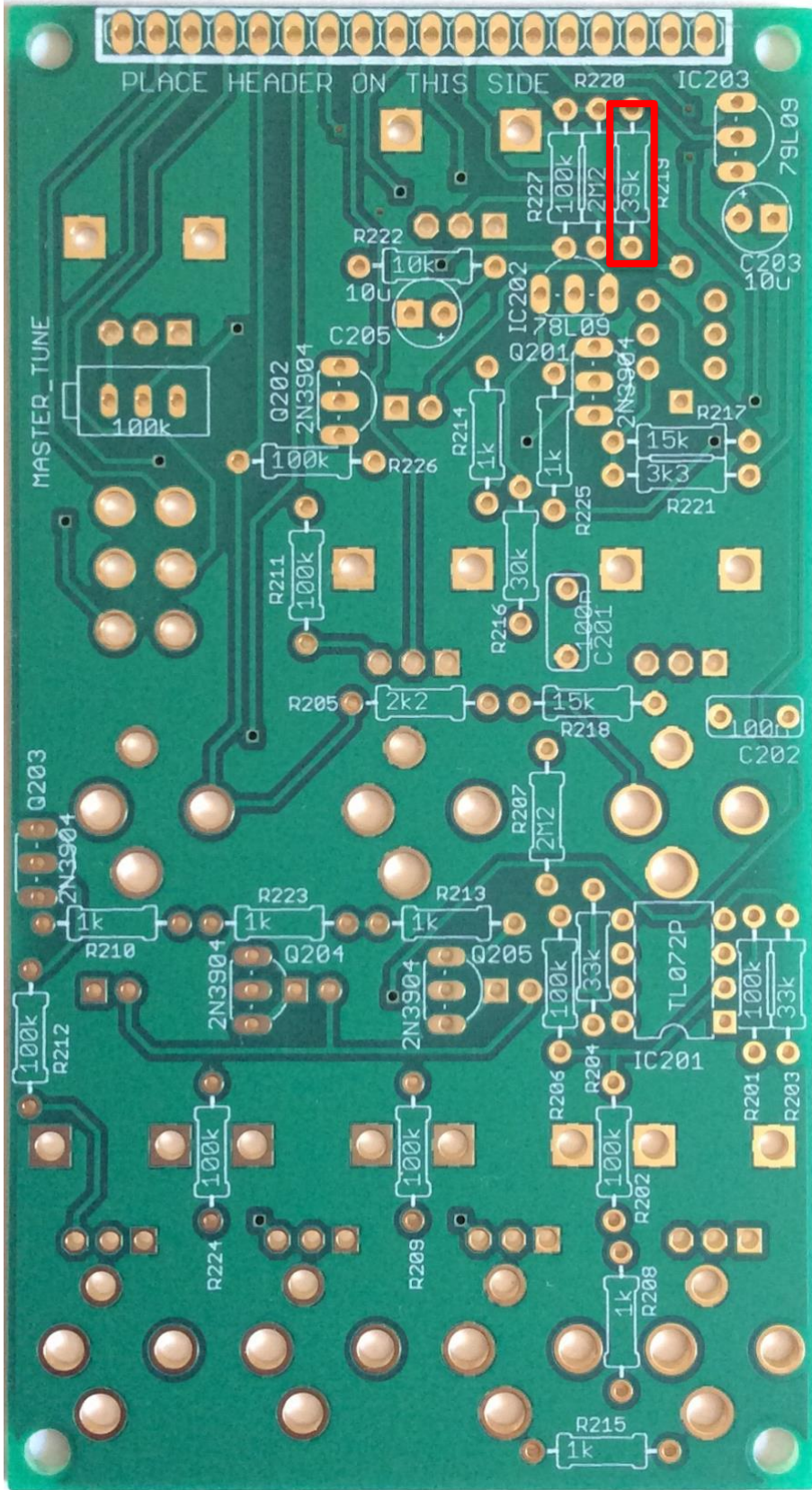

9 - 1 x 39k resistors

IC Sockets

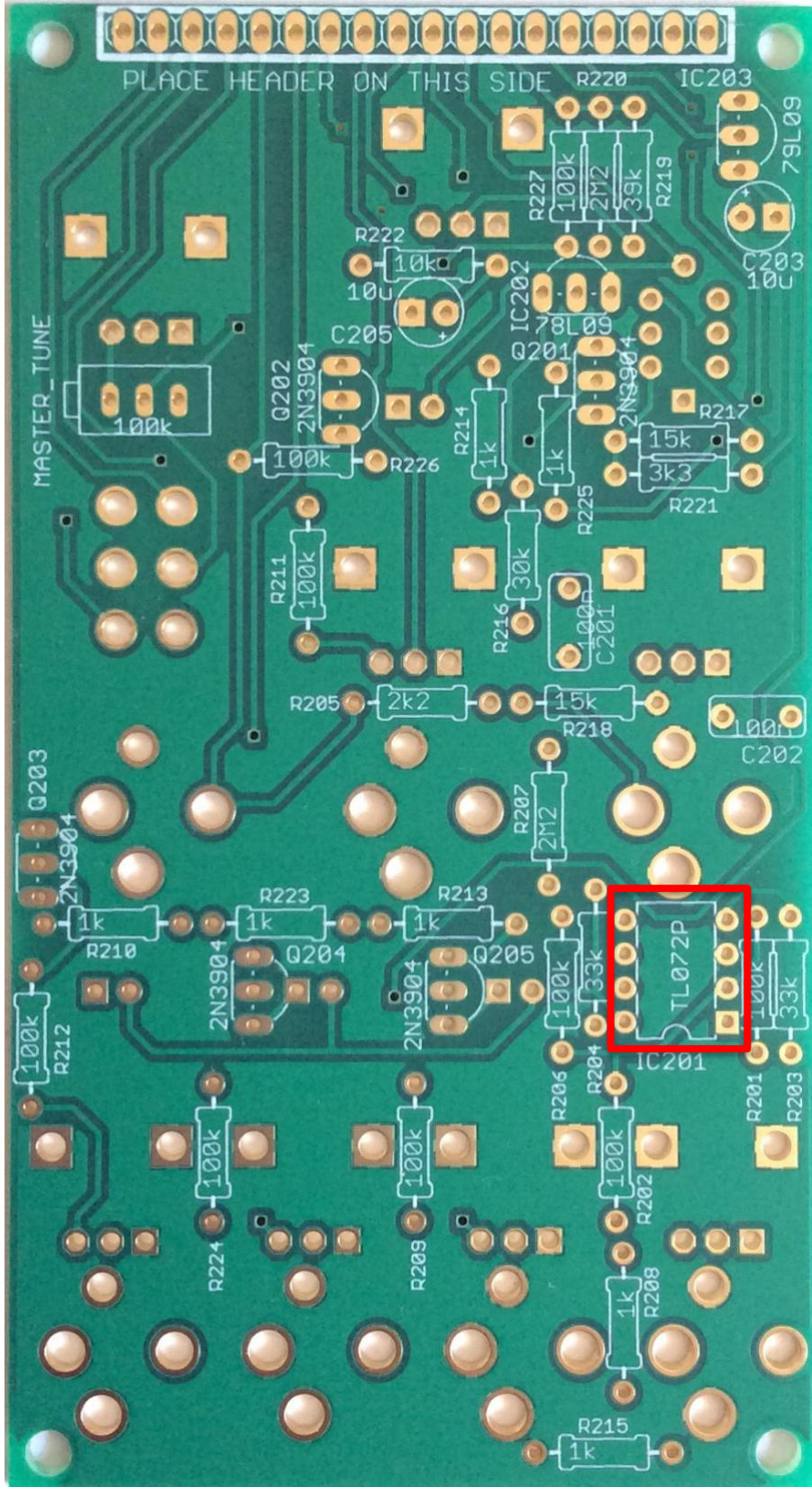

10 – IC socket - Make sure the notch in the socket matches the notch on the silkscreen.

Capacitors

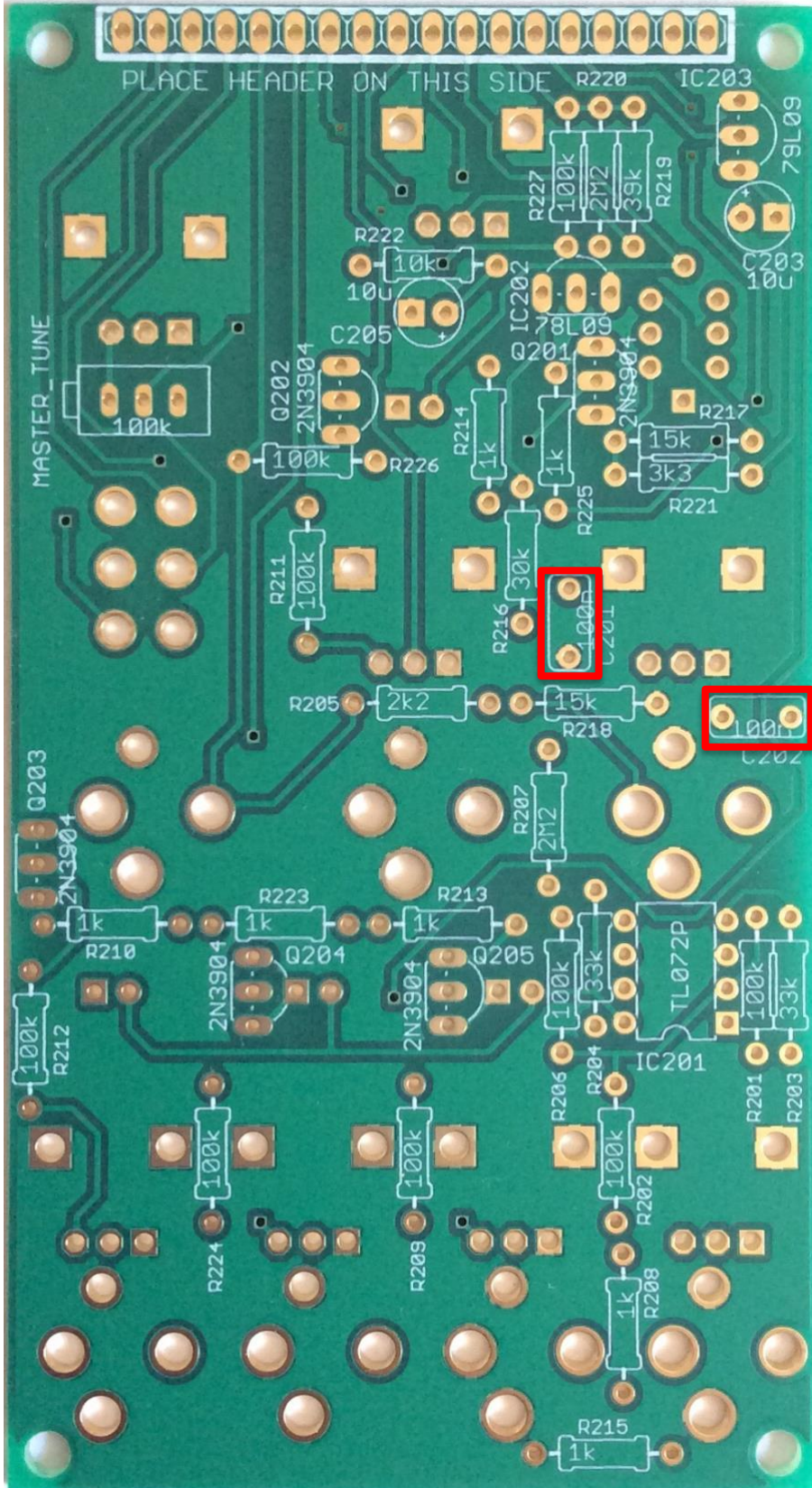

11 - 2 x 100nF capacitors

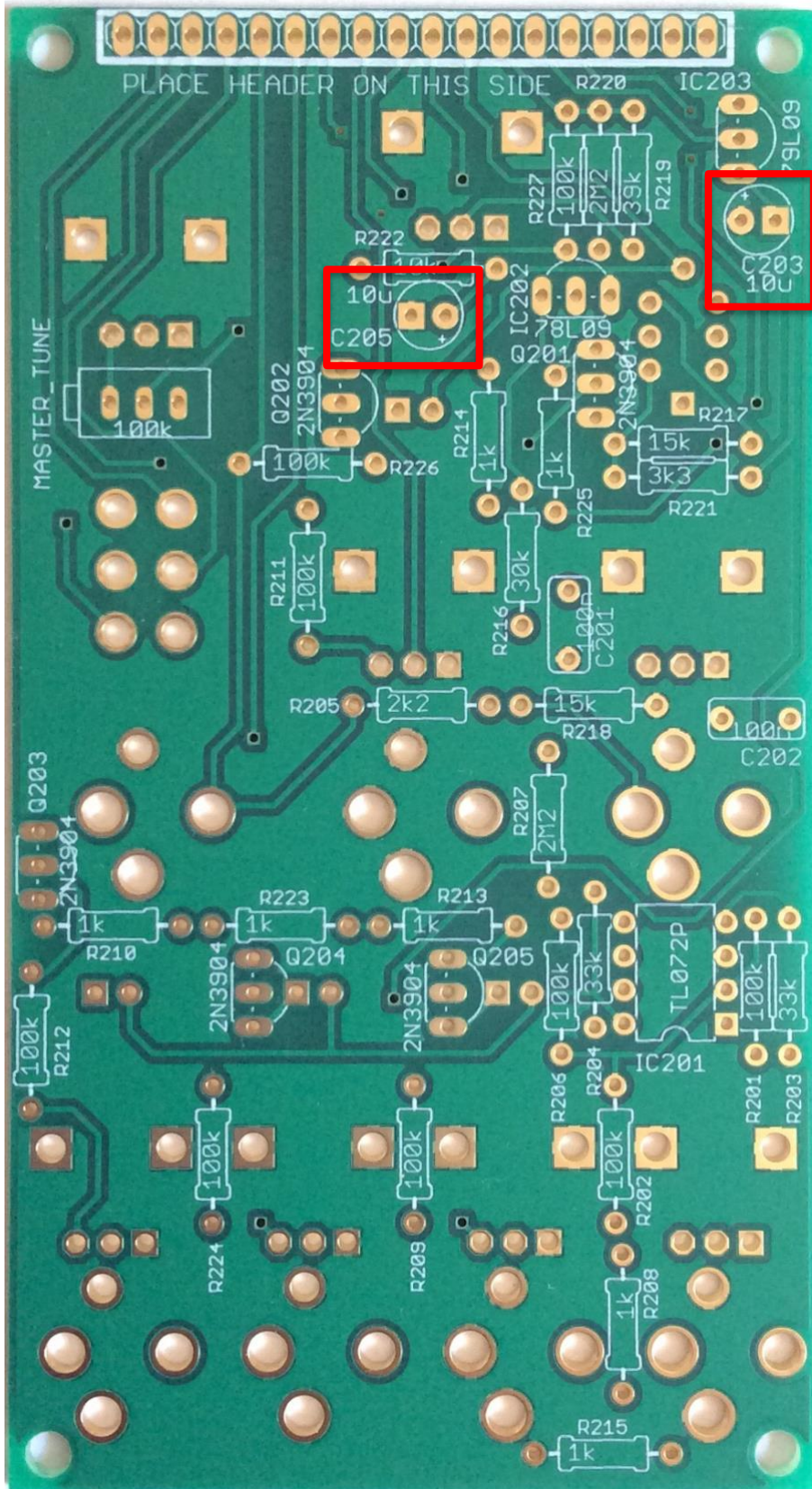

12 – 2 x 10uF capacitors - orientation is vital, the longer lead on the component should go to the circular pad marked with a plus '+' on the PCB. Note the component has a grey stripe on the cylindrical body on the minus side.

Trim Pot

This trim pot is used to tune the oscillator frequency. If you'd like to have say C3 produced when the oscillator frequency controls are set to 50%, then install this trim pot. (recommended)

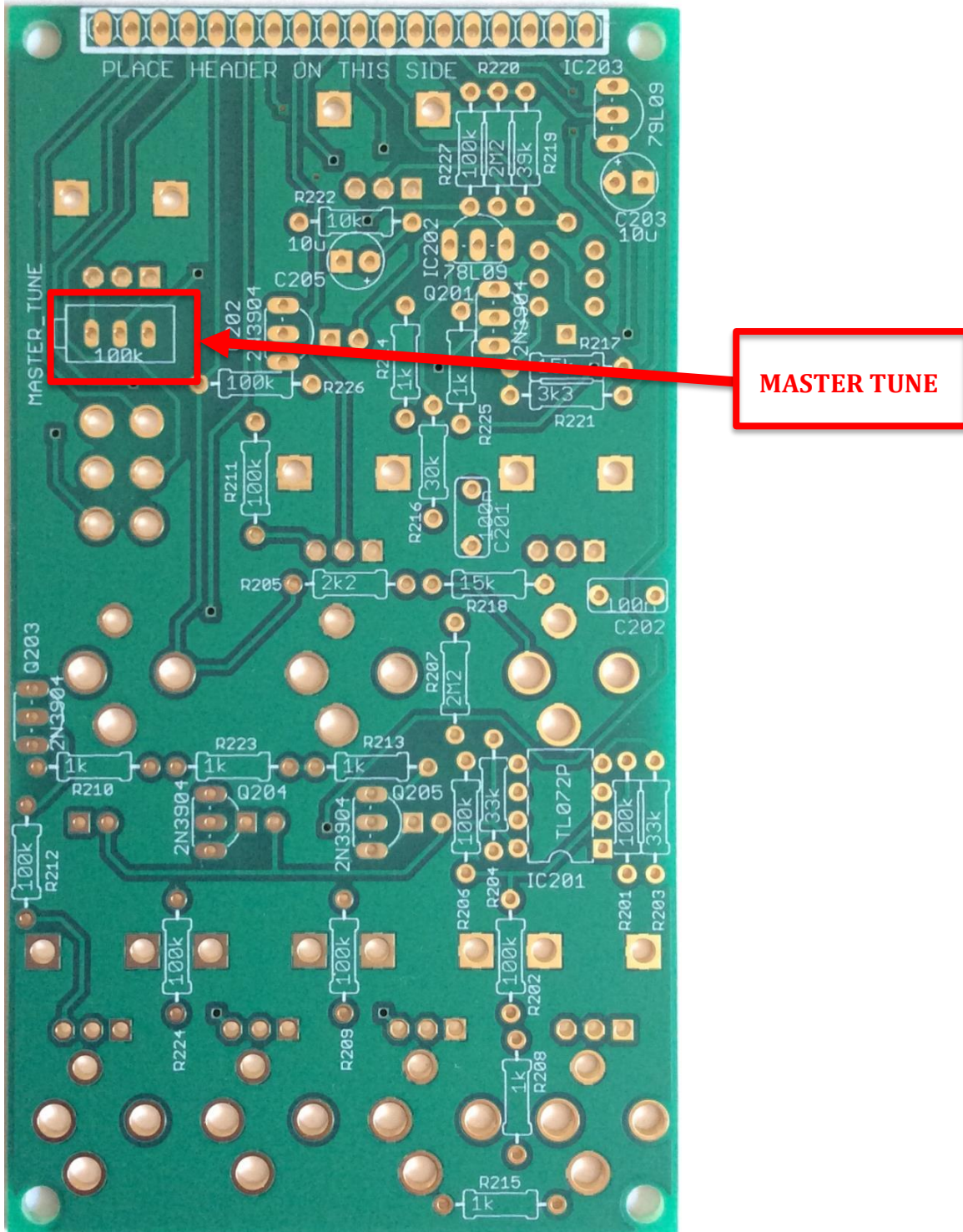

13 - 1 x 100k blue side adjust trimpot

Transistors

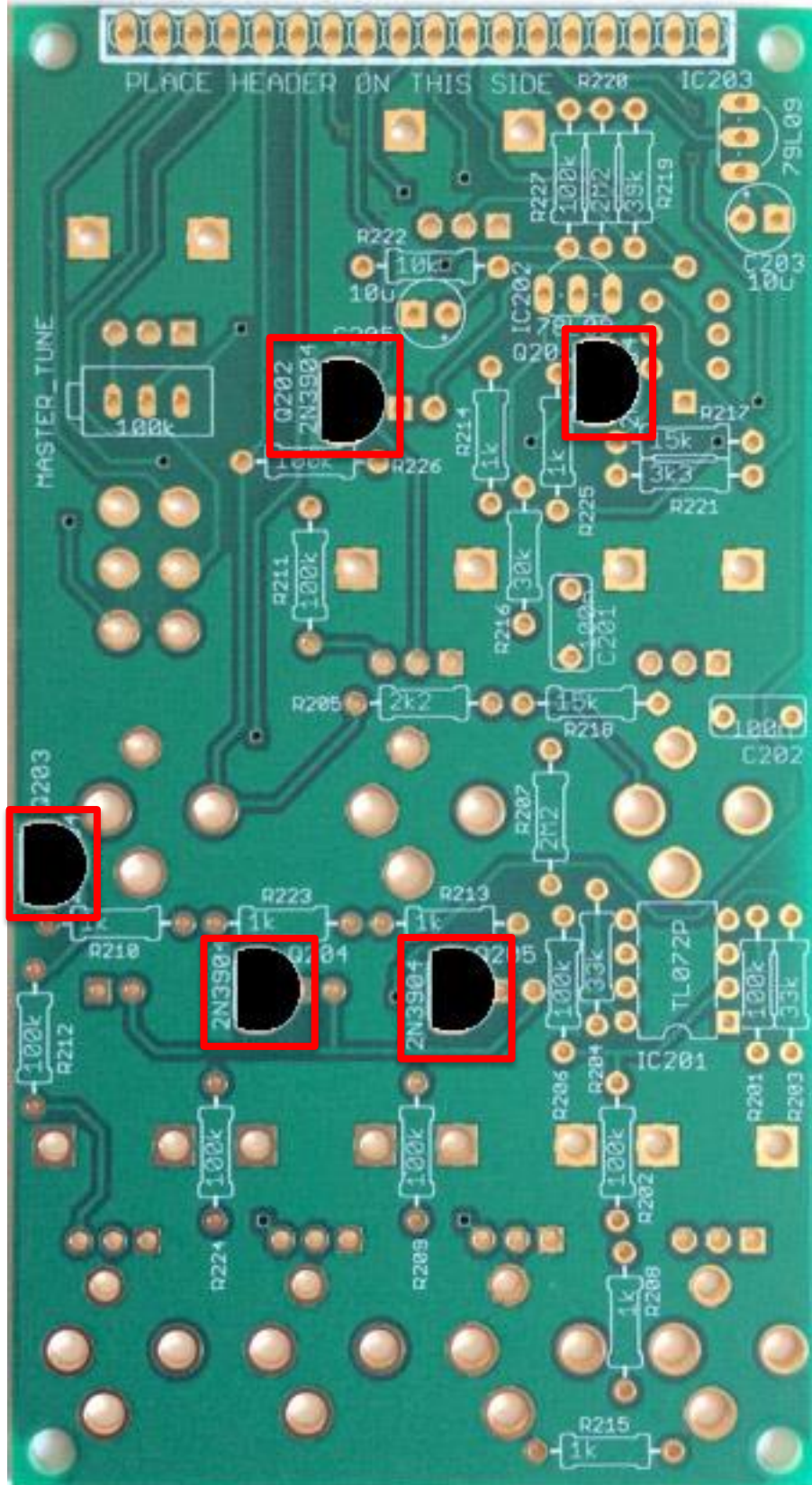

14 – 5 x 2N3904 transistors - Ensure the flat face on the component matches the flat face on the PCB silkscreen. Orientation is vital.

Be careful to individually identify all the transistors, there are many different types to separate, make sure what you have matches the label on the transistor bag.

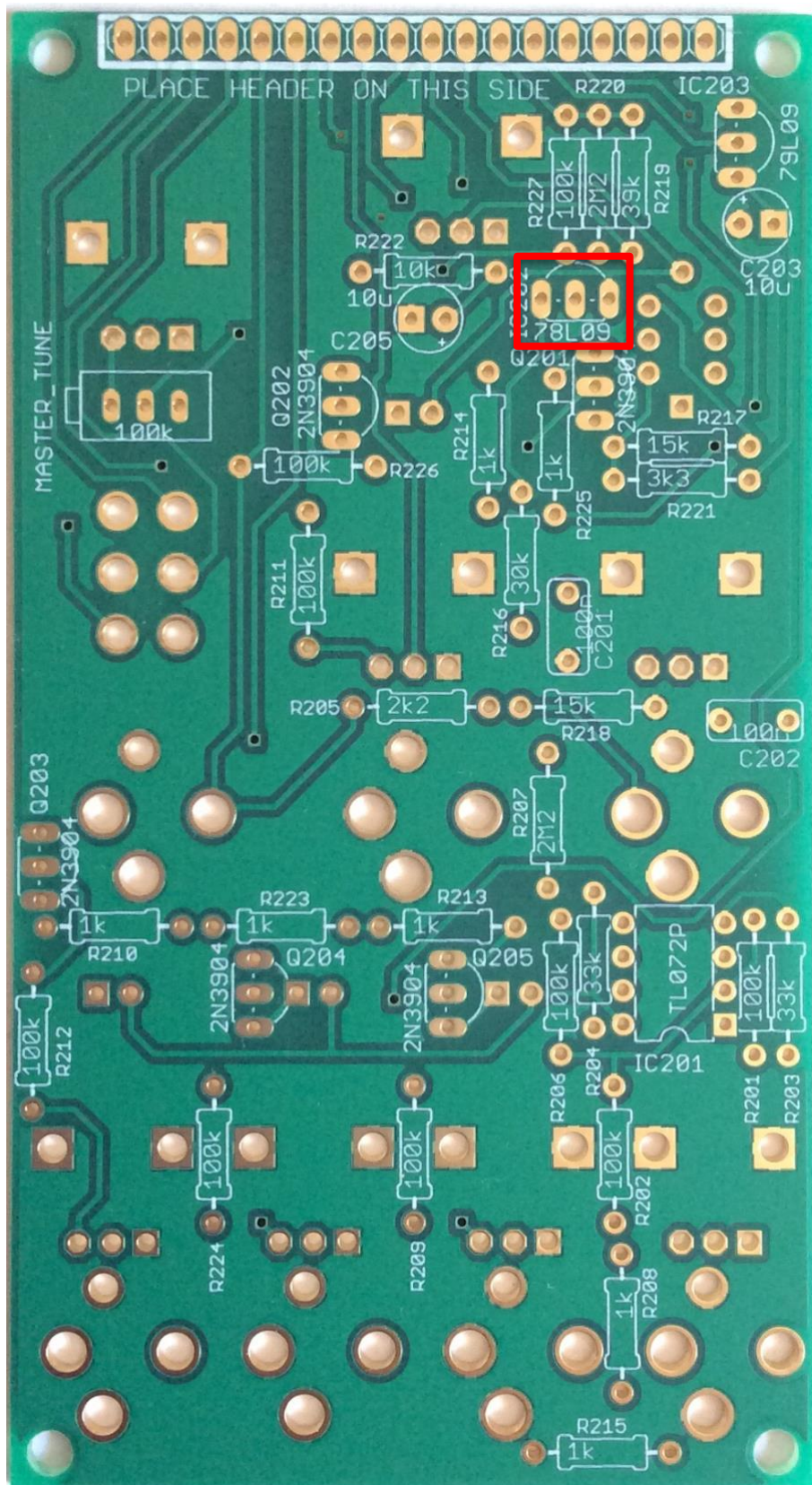

15 – 1 x 78L09 transistor - Ensure the flat face on the component matches the flat face on the PCB silkscreen. Orientation is vital.

Be careful to individually identify all the transistors, there are many different types to separate, make sure what you have matches the label on the transistor bag.

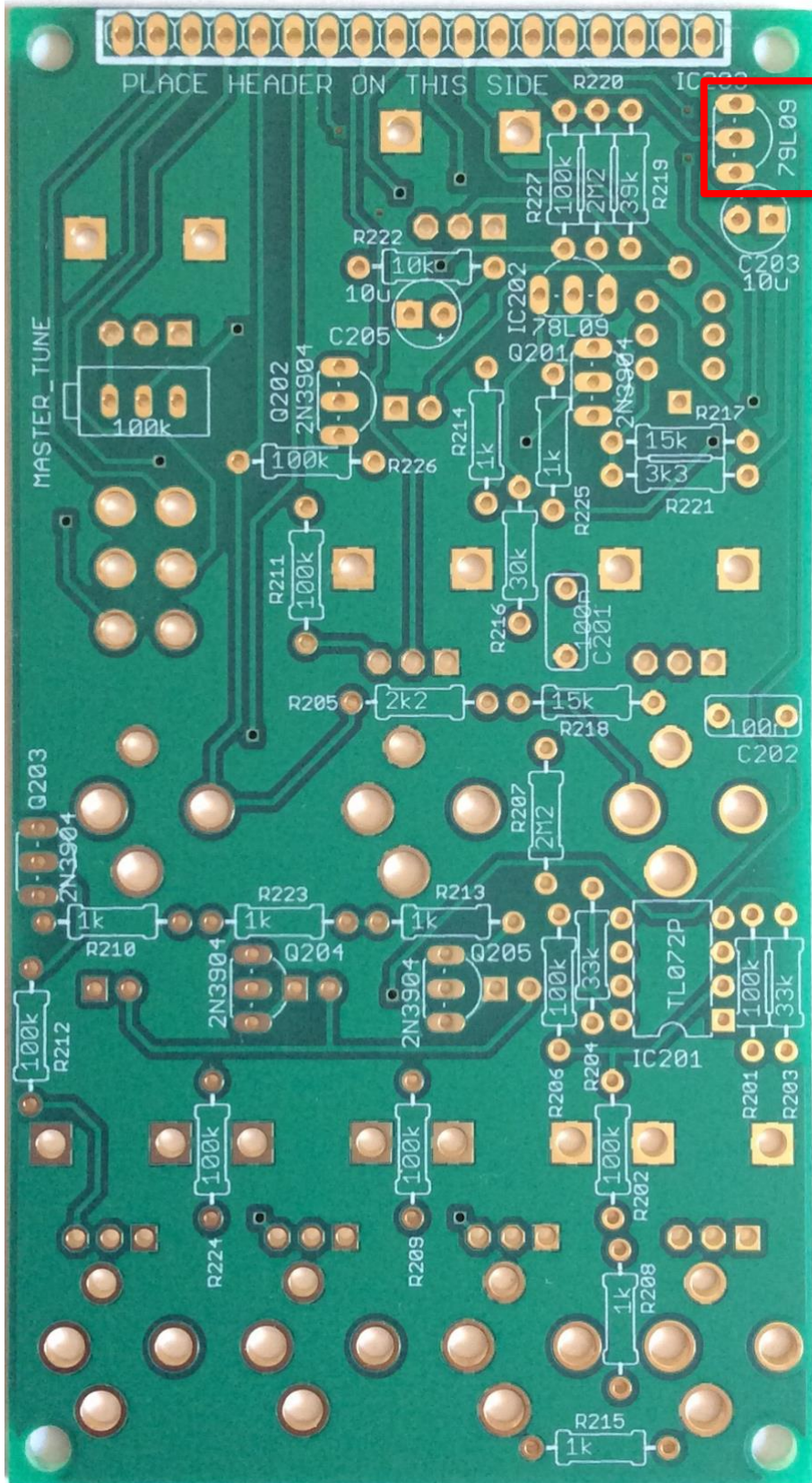

16 – 1 x 79L09 transistor - Ensure the flat face on the component matches the flat face on the PCB silkscreen. Orientation is vital.

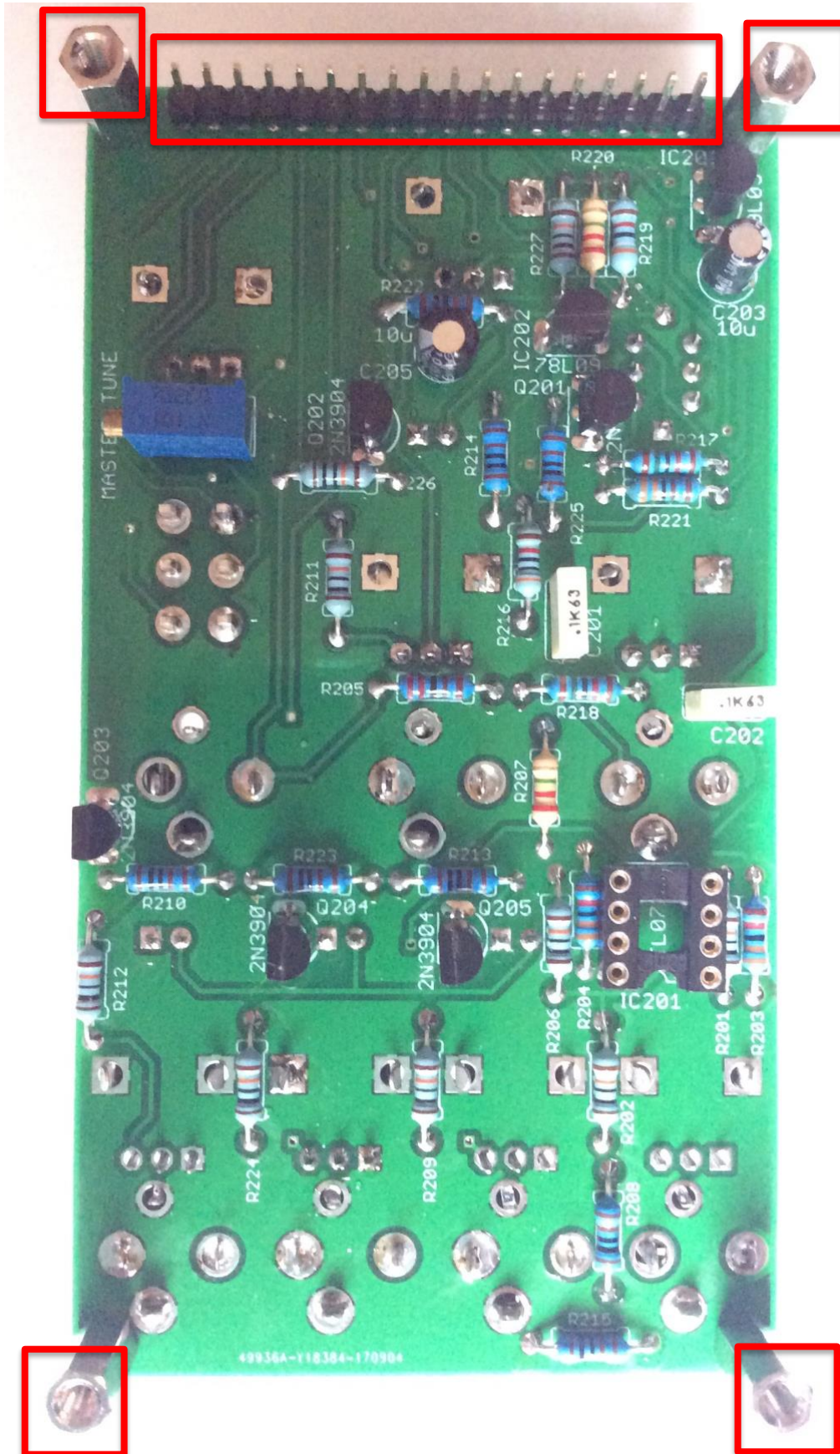

17 – 1 x 18 pin male header - now is also a good time to screw hex standoffs onto the front PCB

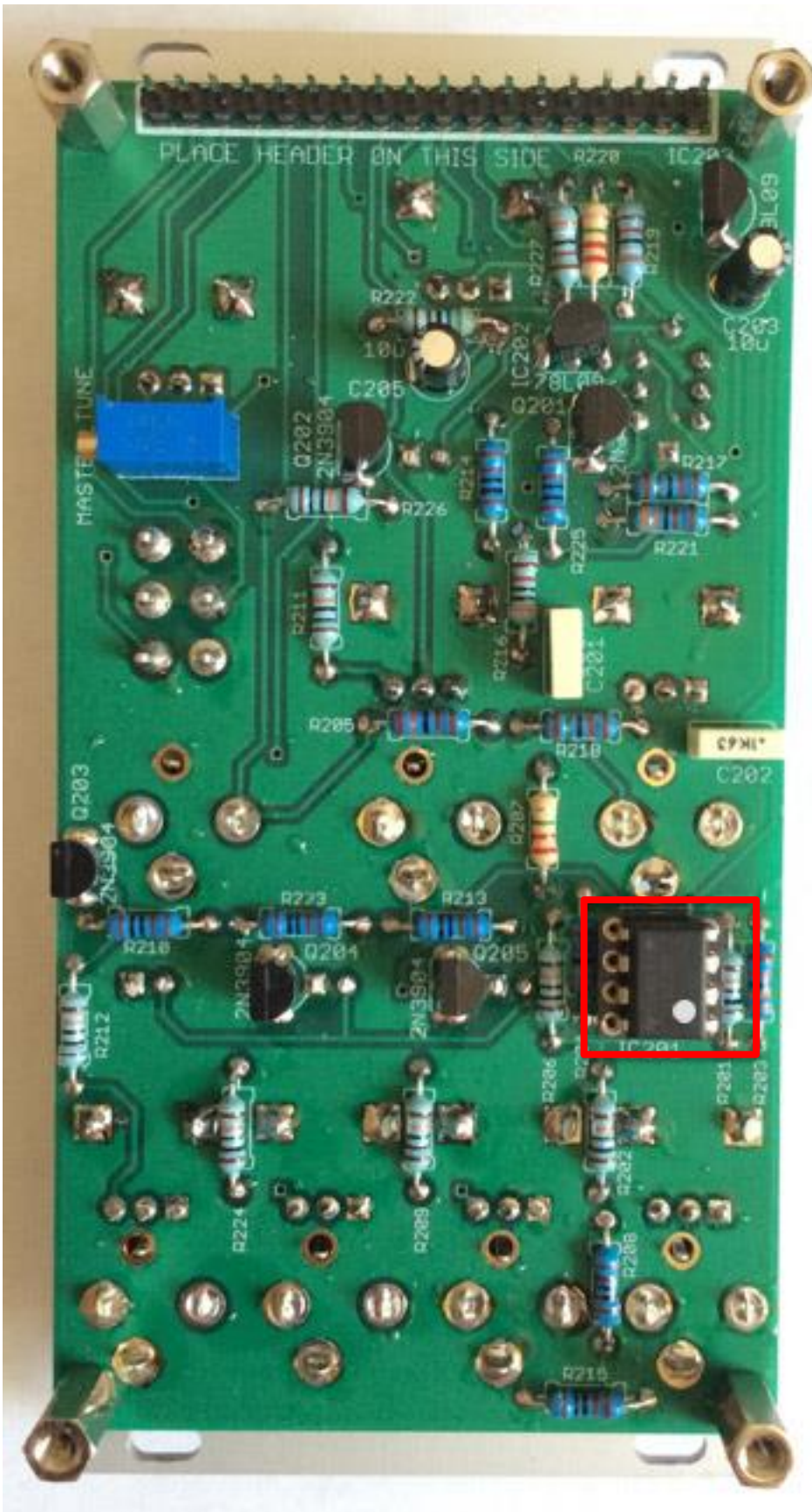

18 - 1 x TL072 opamp - orientation is vital, for this opamp match the dot with the notch on the PCB silkscreen and IC Socket.

Panel Components

These components should be inserted but NOT SOLDERED until the panel has been placed on top. This is to ensure that the PCB fits the panel properly.

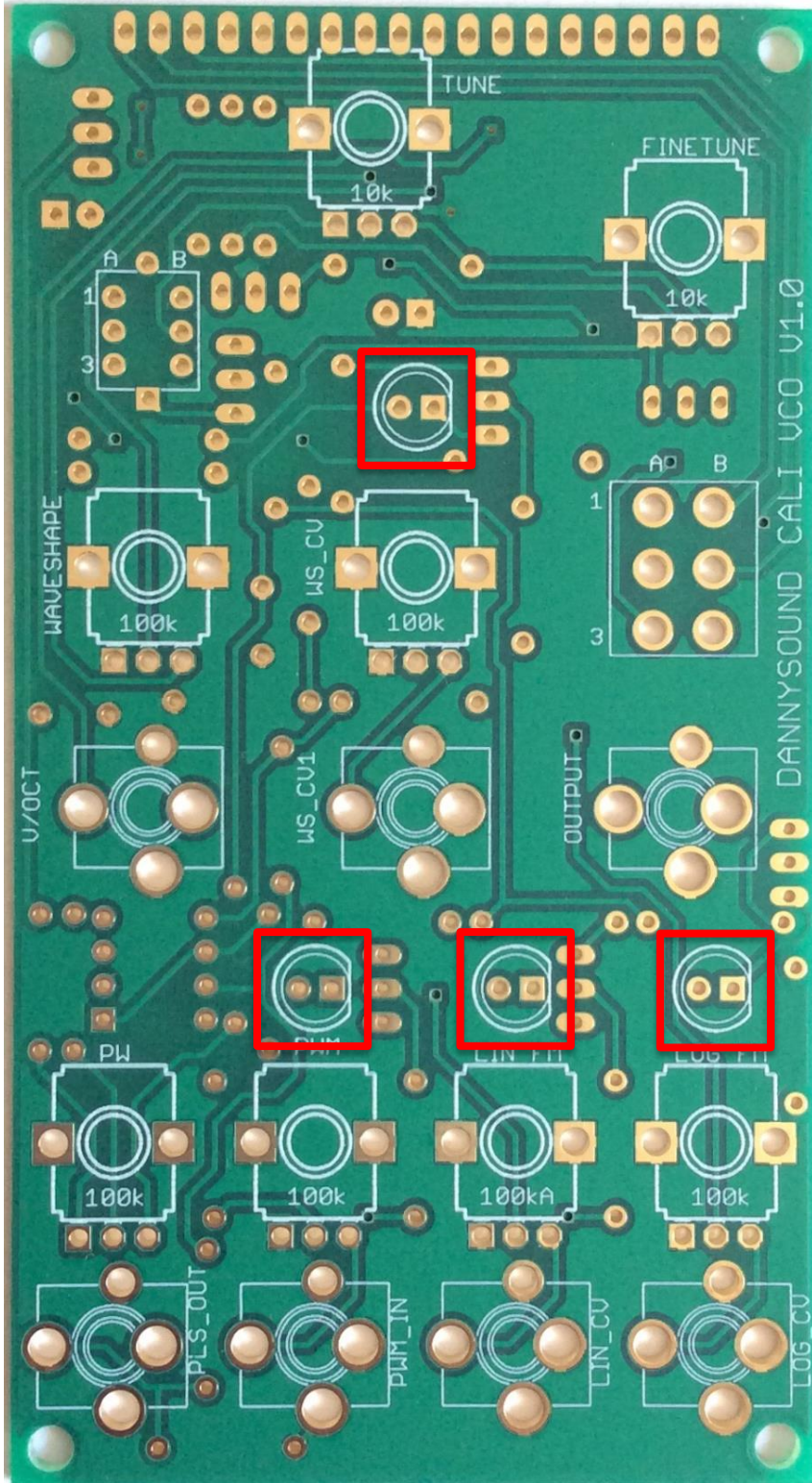

19 – 4 x LEDs - orientation is vital, the shorter leg of the LED should go to the square pad and flat side of the PCB silkscreen diagram.

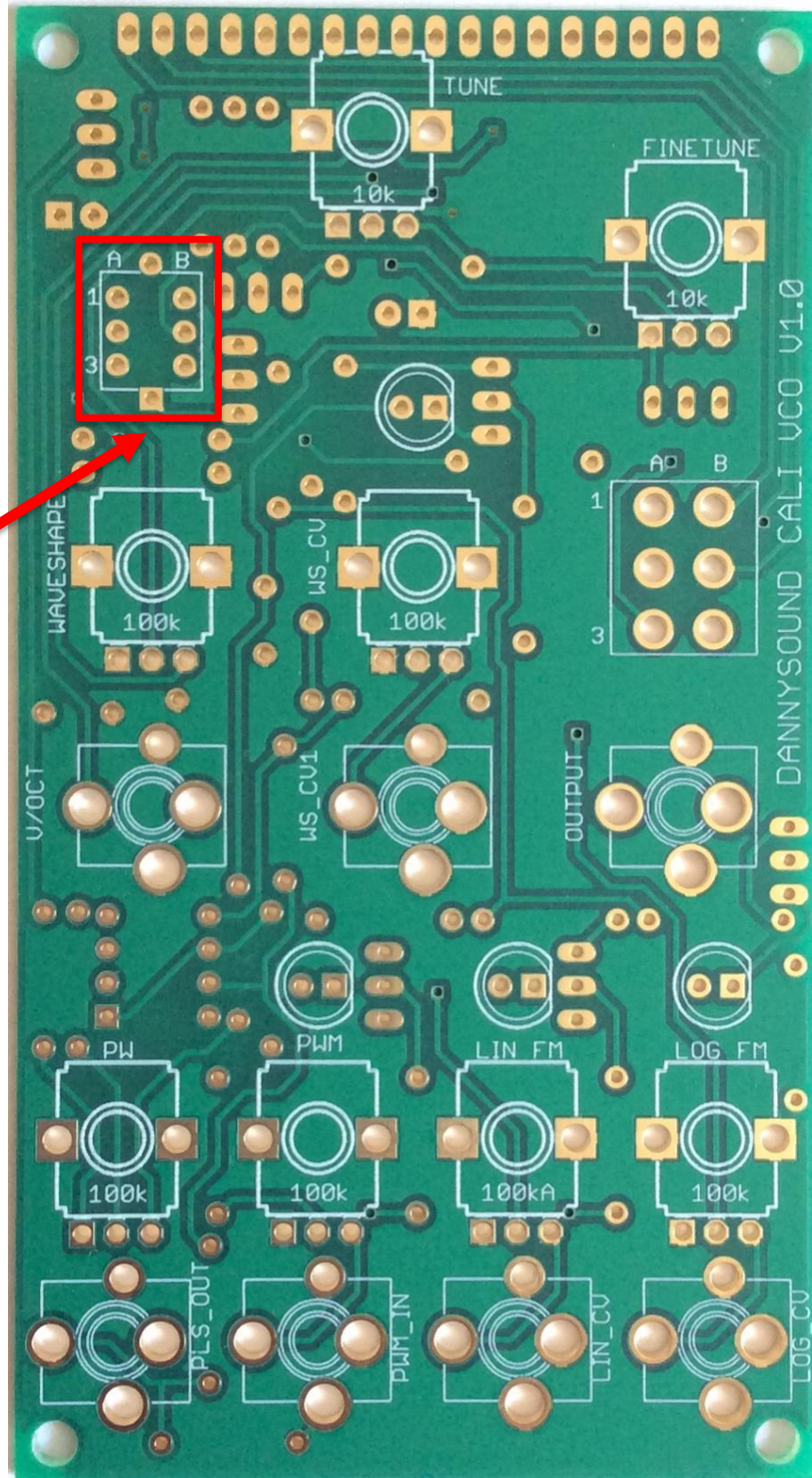

The red dot on the black body of the pushbutton switch goes on this side

21 - 1 x Illuminated push button switch - orientation is vital

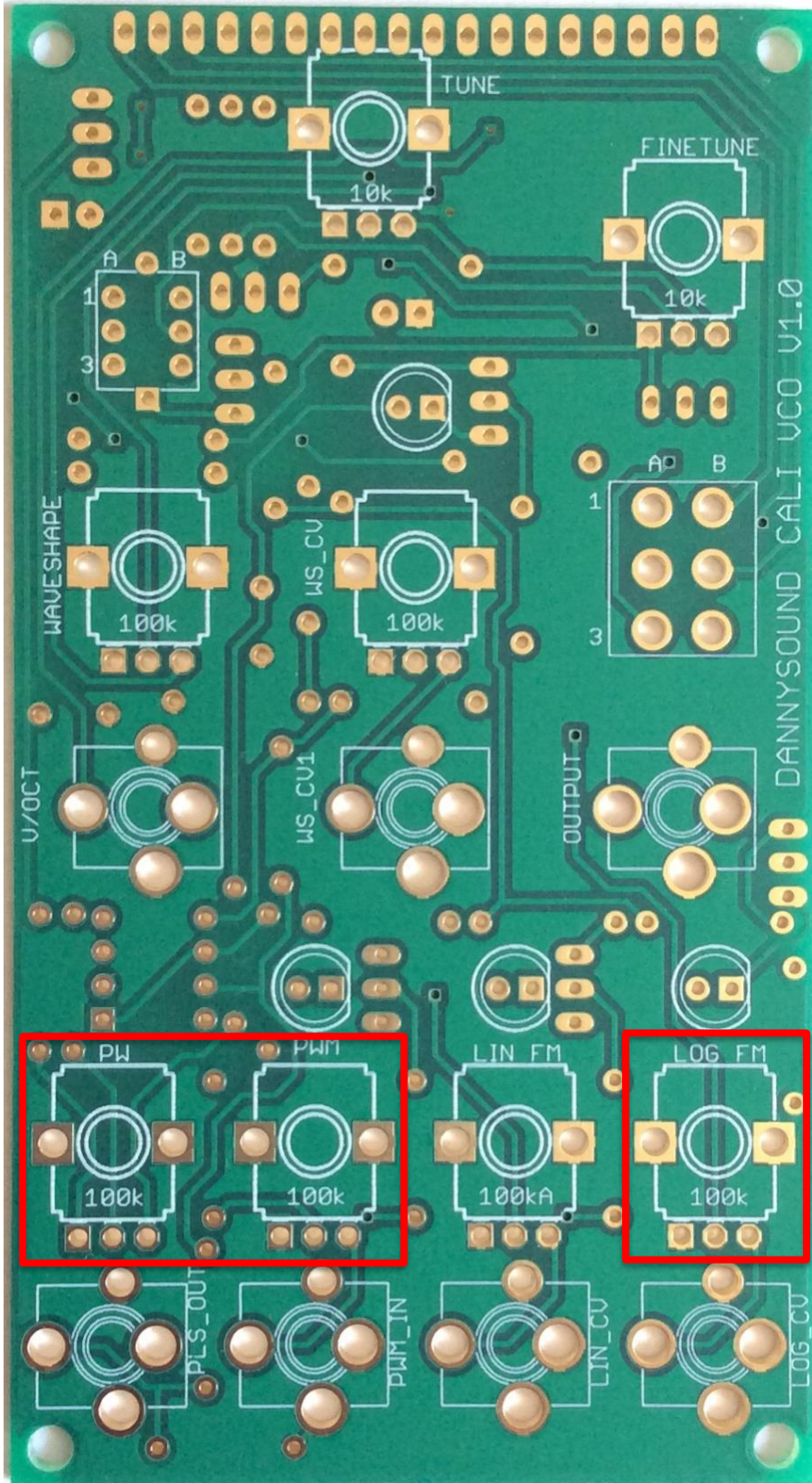

22 - 3 x B100k blue body plastic shaft pots



B100K

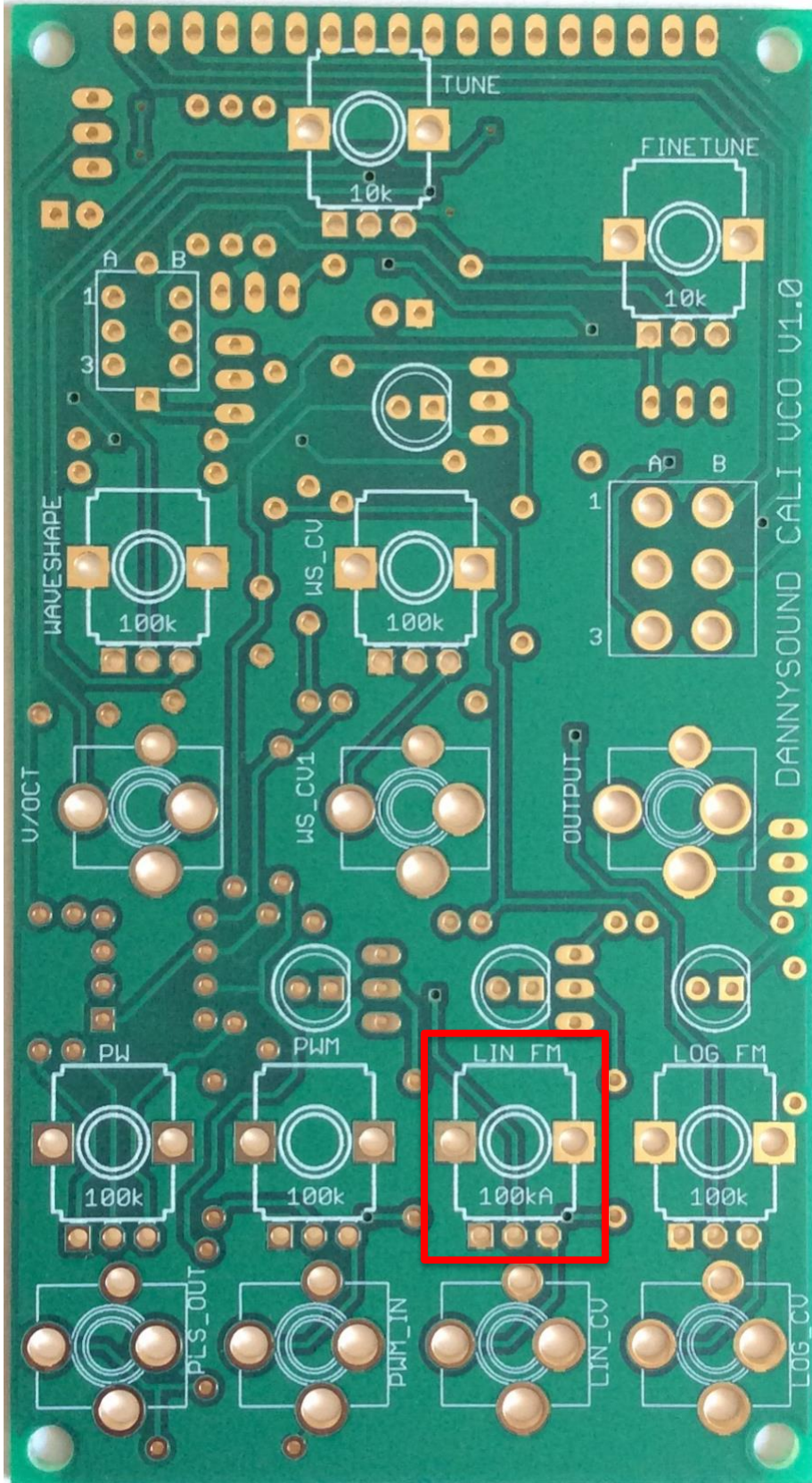

23 - 1 x A100k blue body plastic shaft pots



A100K

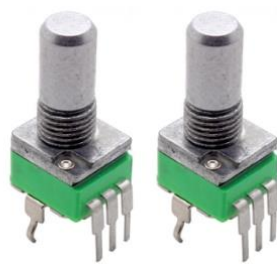
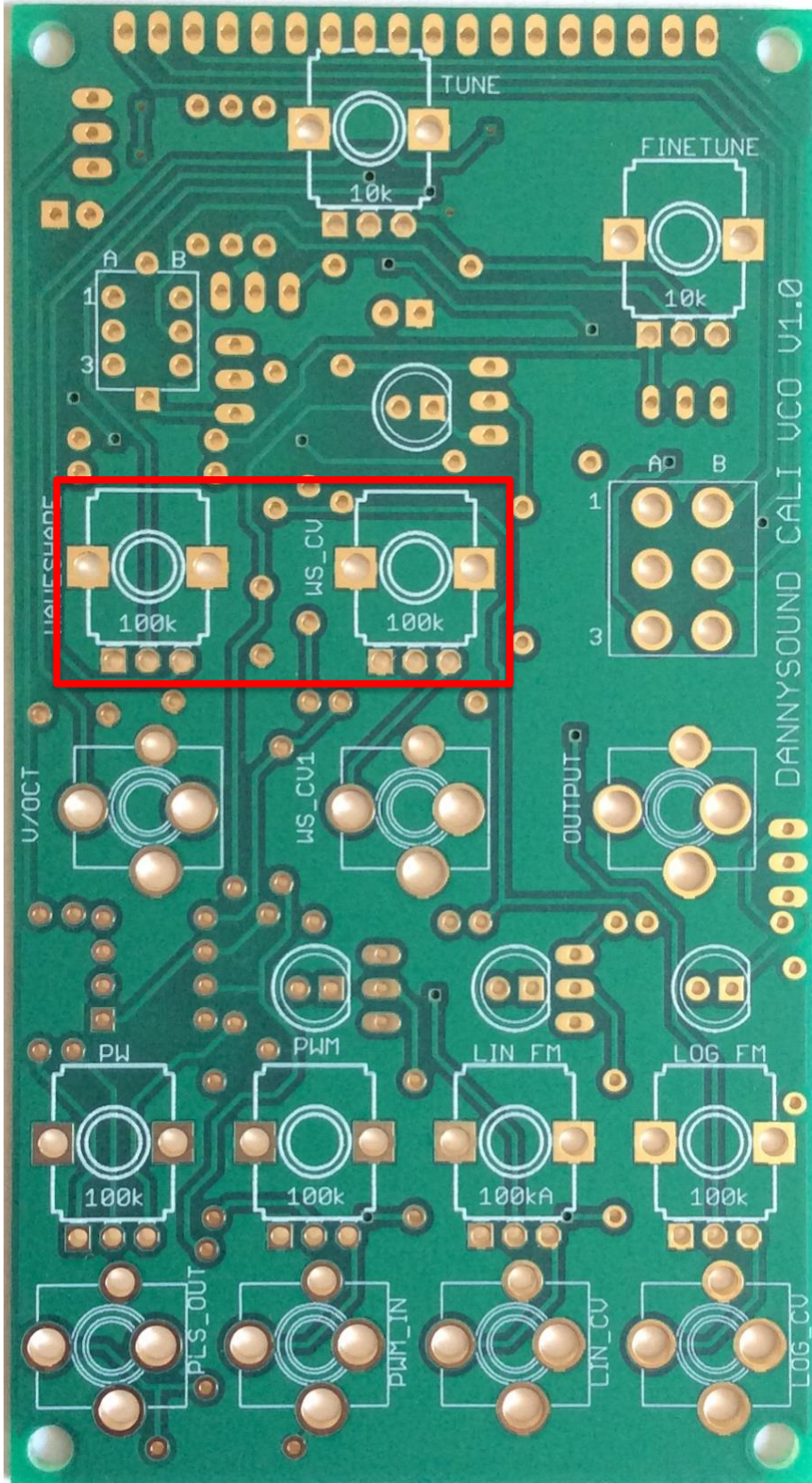

24 - 2 x 100k green body metal shaft pots

B100K

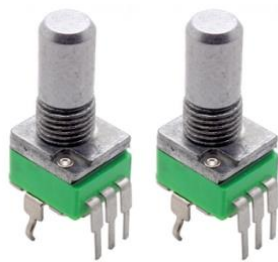
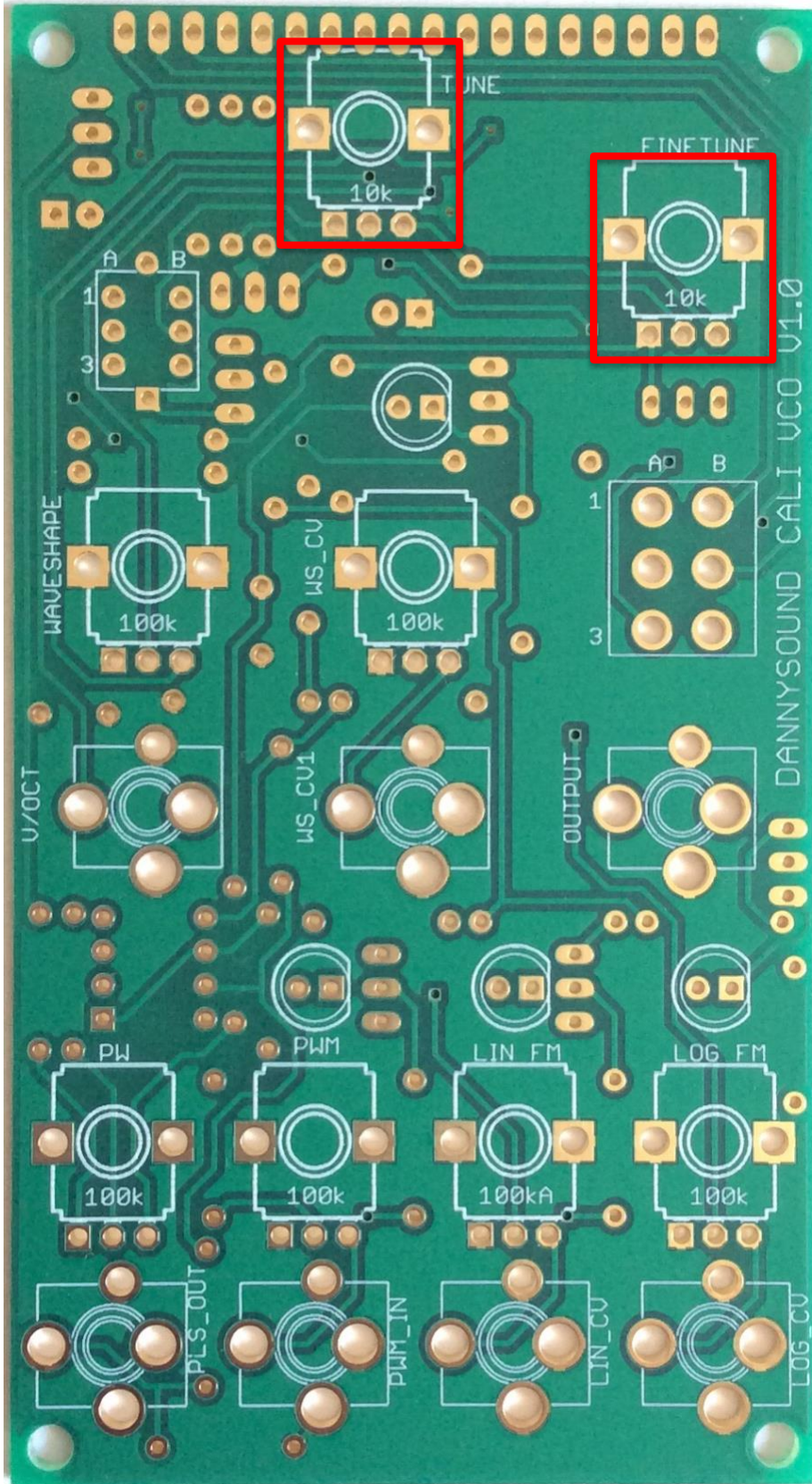

25 - 2 x 10k linear alpha pots

B10K

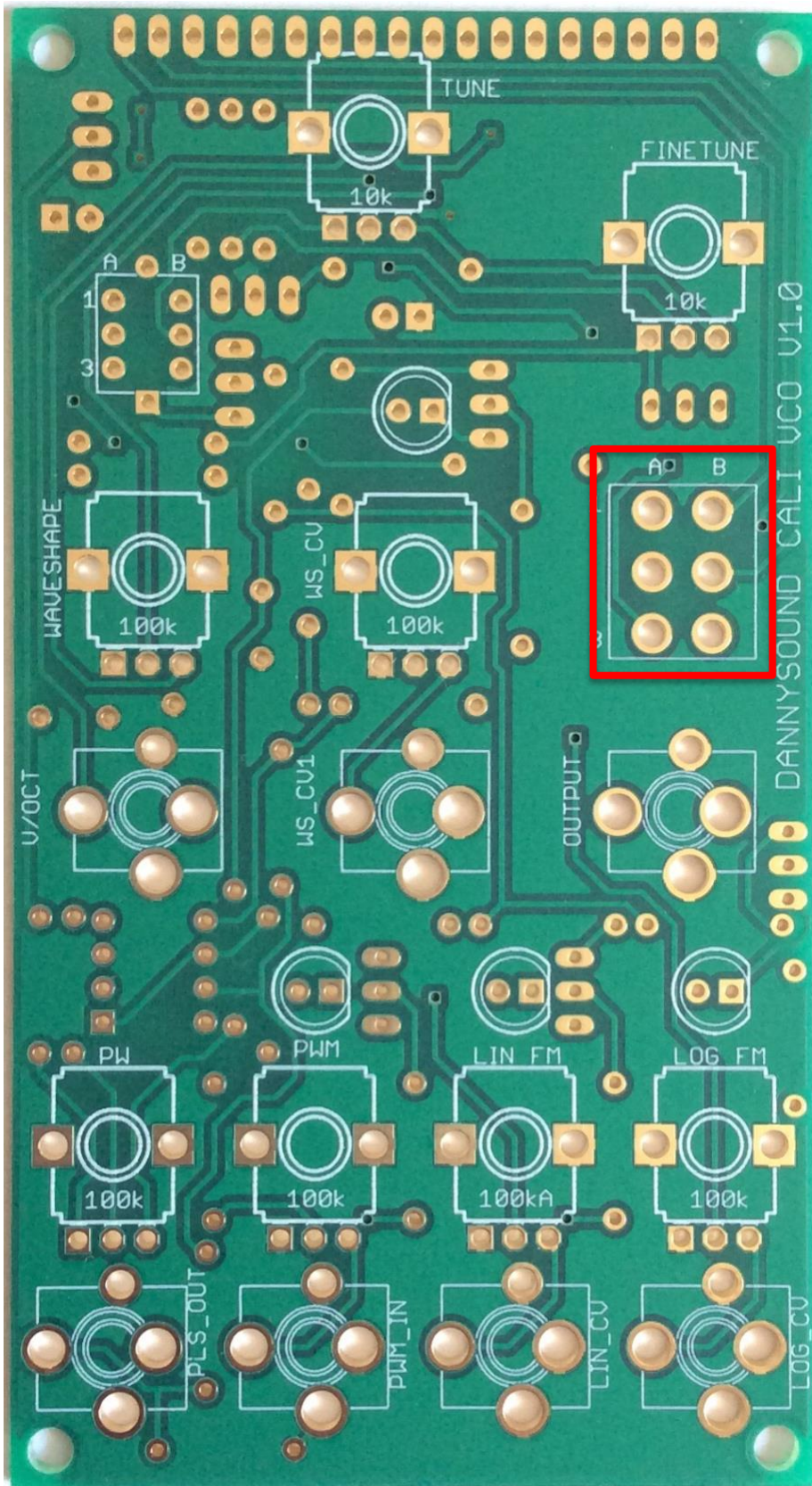

26 - 1 x DPDT toggle switch

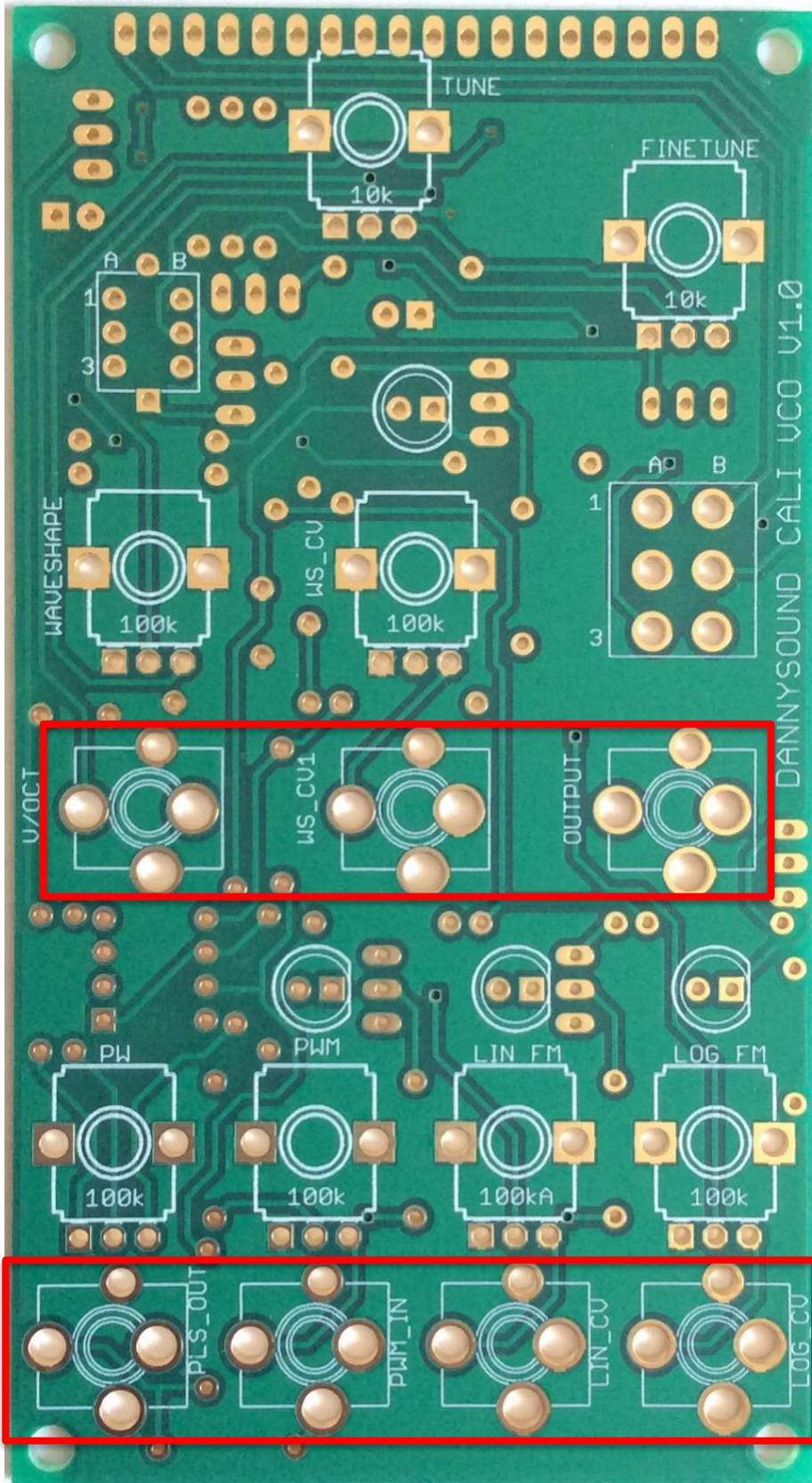

27 - 7 x jack sockets

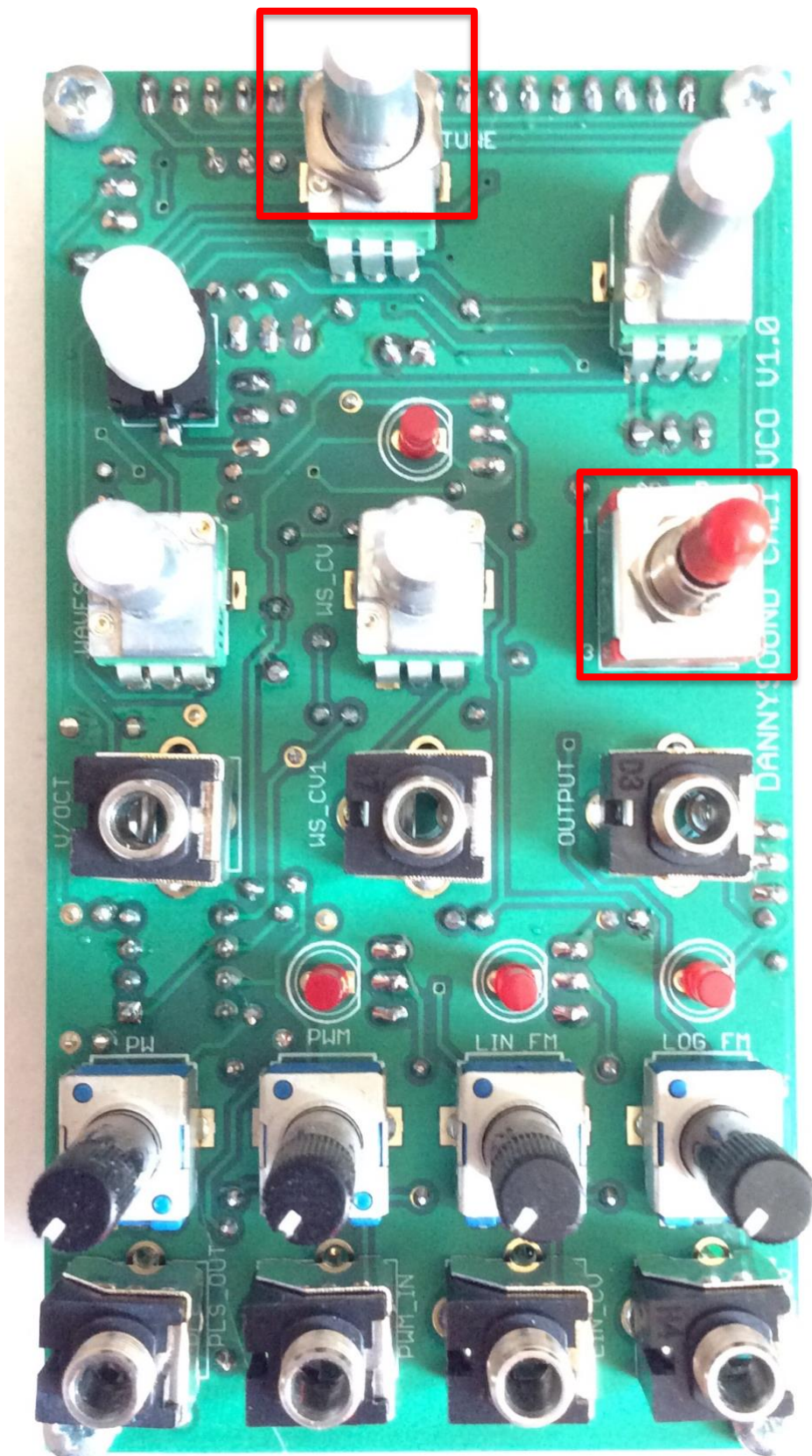

28 - Insert 1 x pot nut and 1 x switch nut - these will sit behind the panel

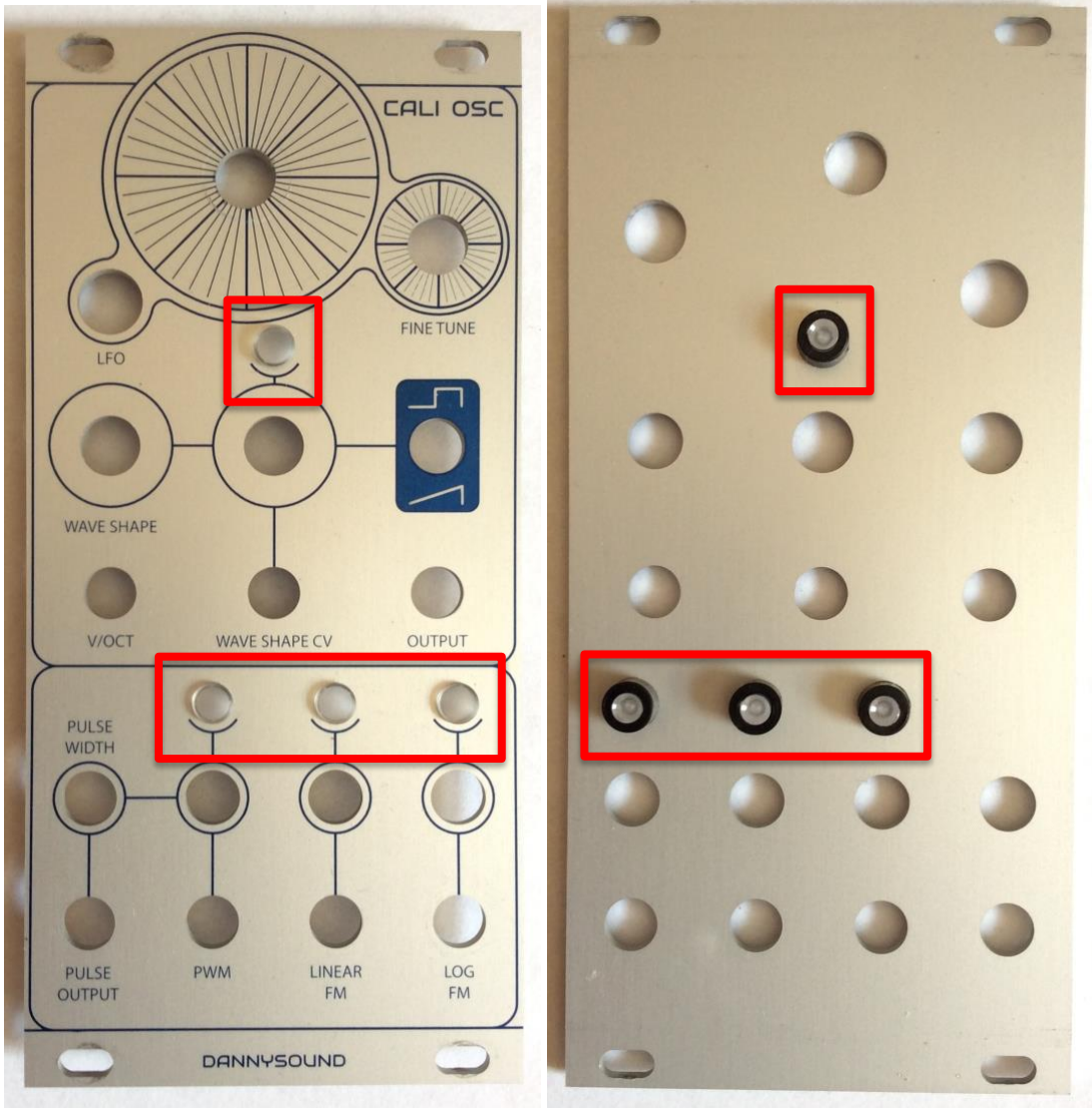

29 - Insert LED light pipes and retaining clips

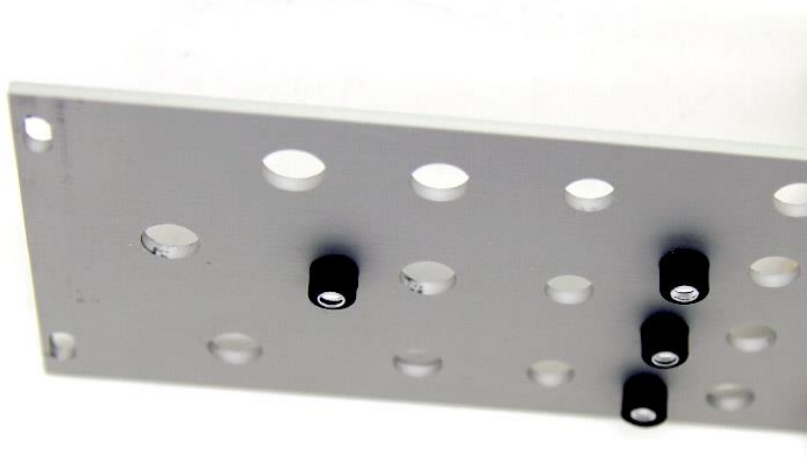

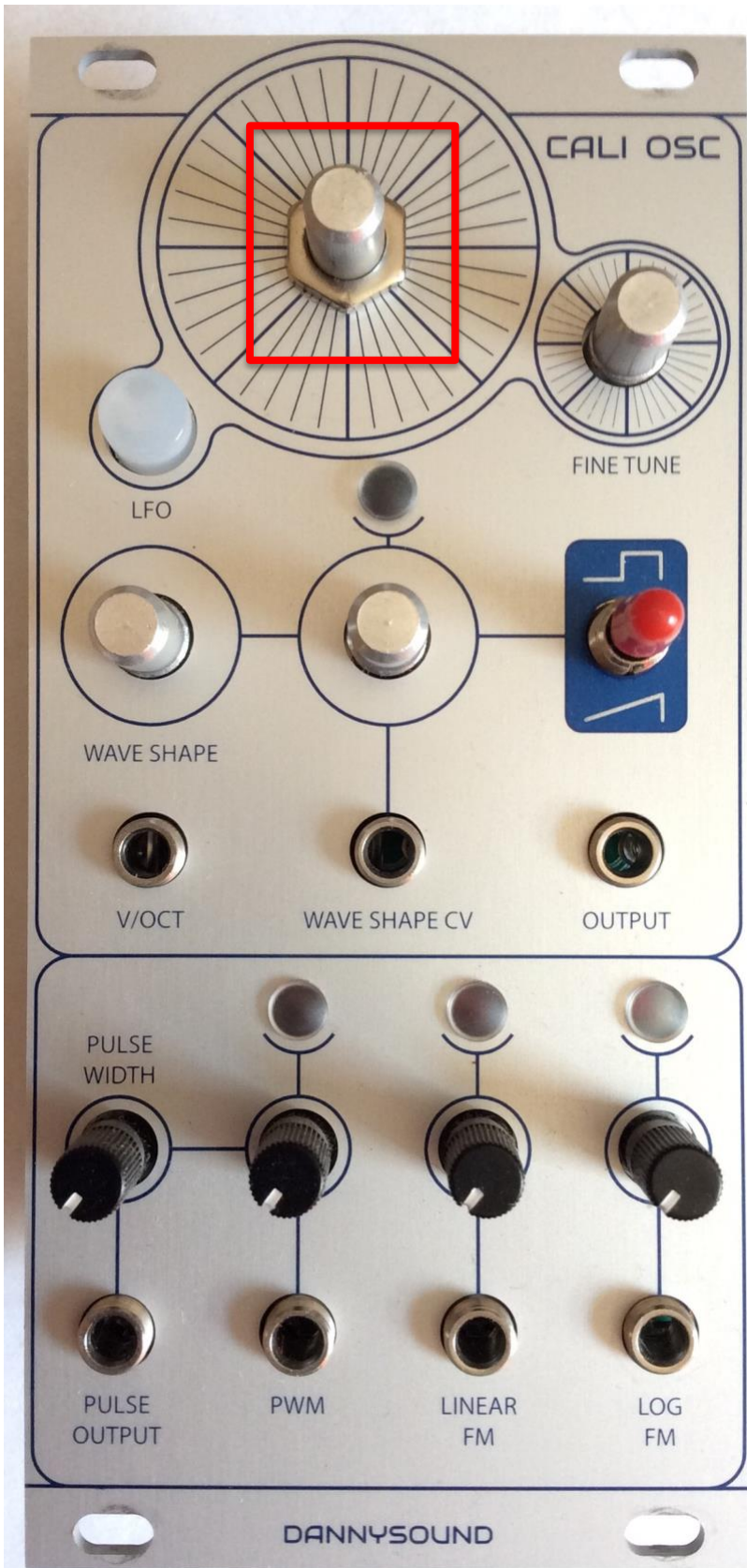

30 – Fit the panel and insert second pot nut but do not fully tighten.



31 – Centre the knob with the panel graphics then remove knob and tighten nut.

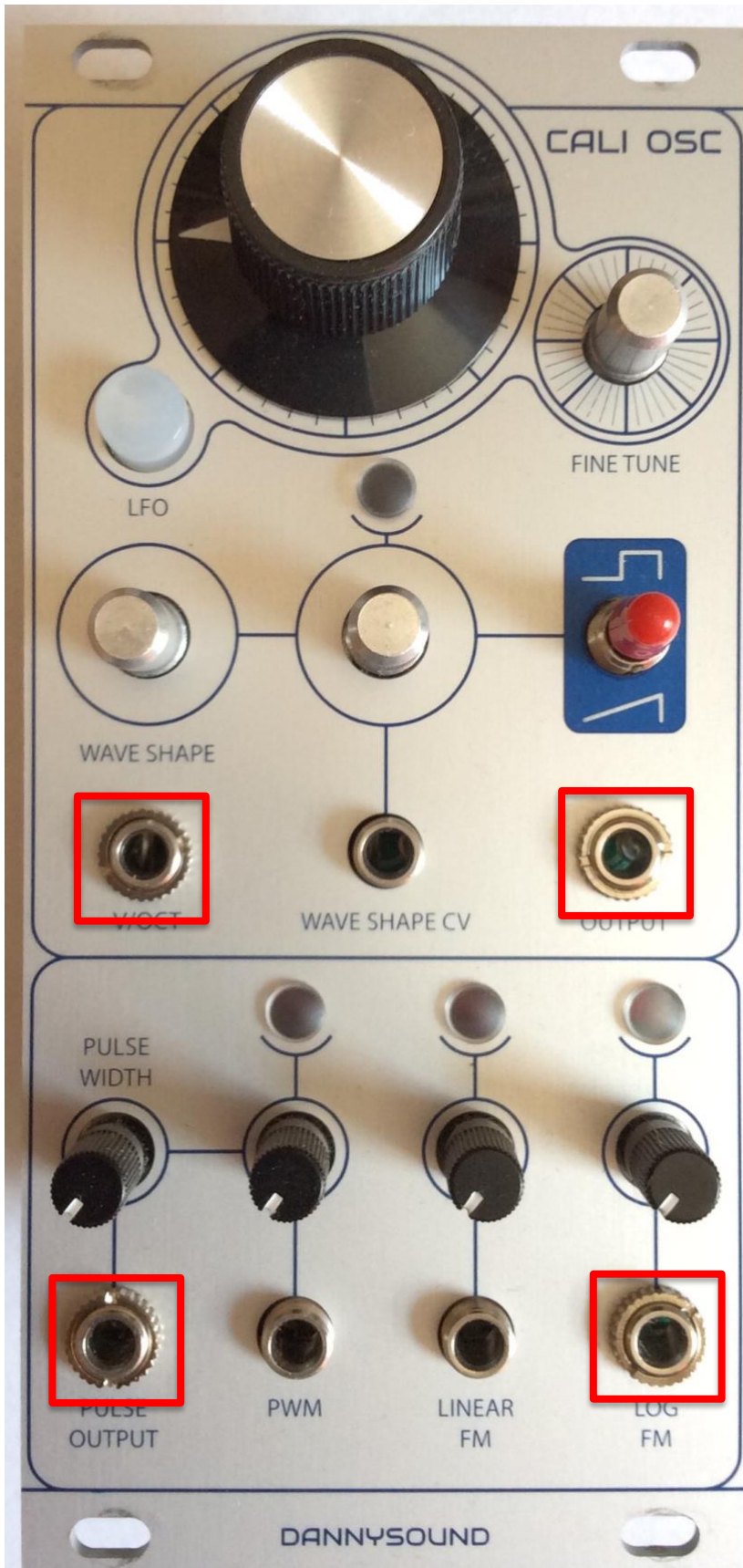

32 – Solder one pin on each of the four outer jack sockets then add nuts to keep panel in place.



33 - Add knobs and solder one ground tab of each pot.

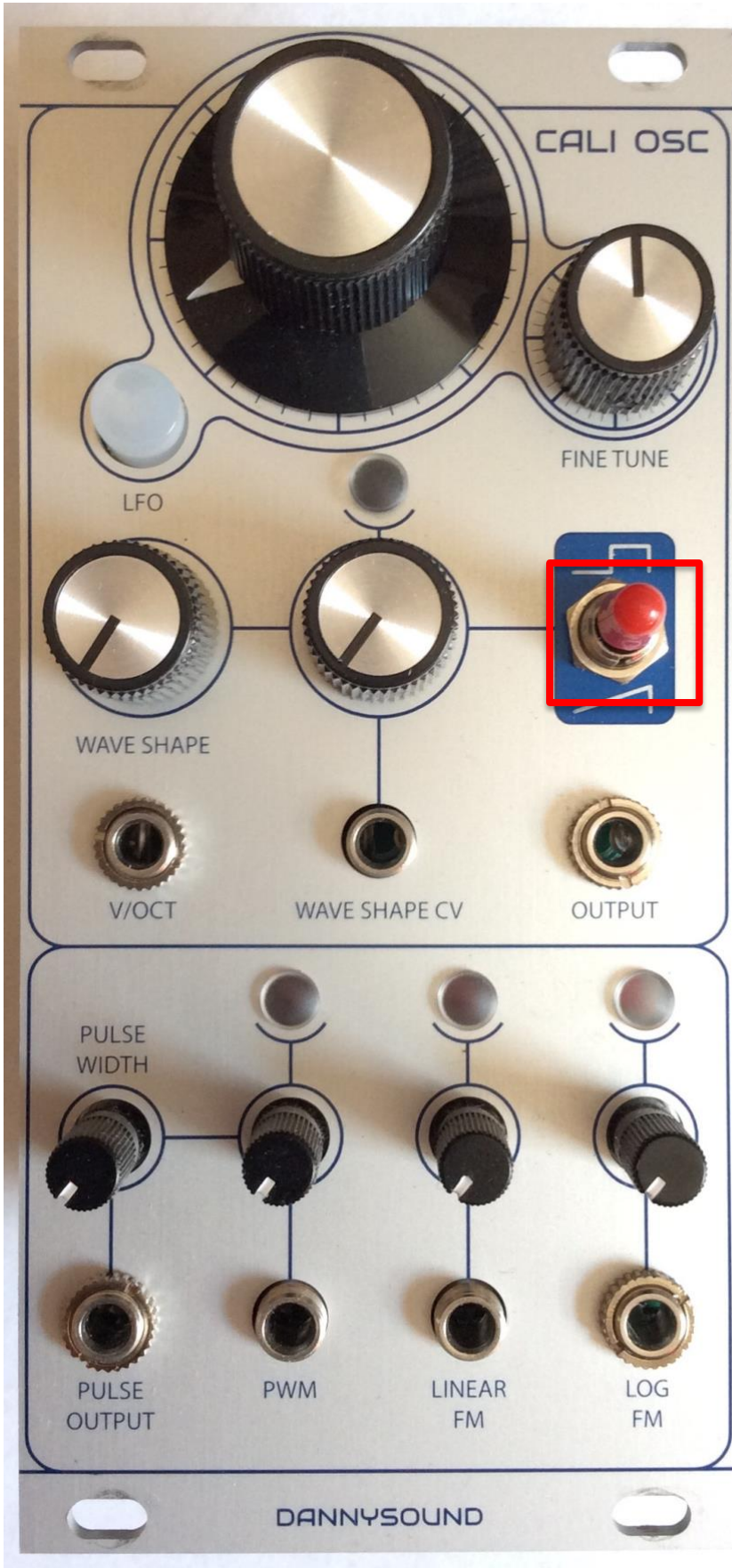

34 – Add nut and solder switch in place.

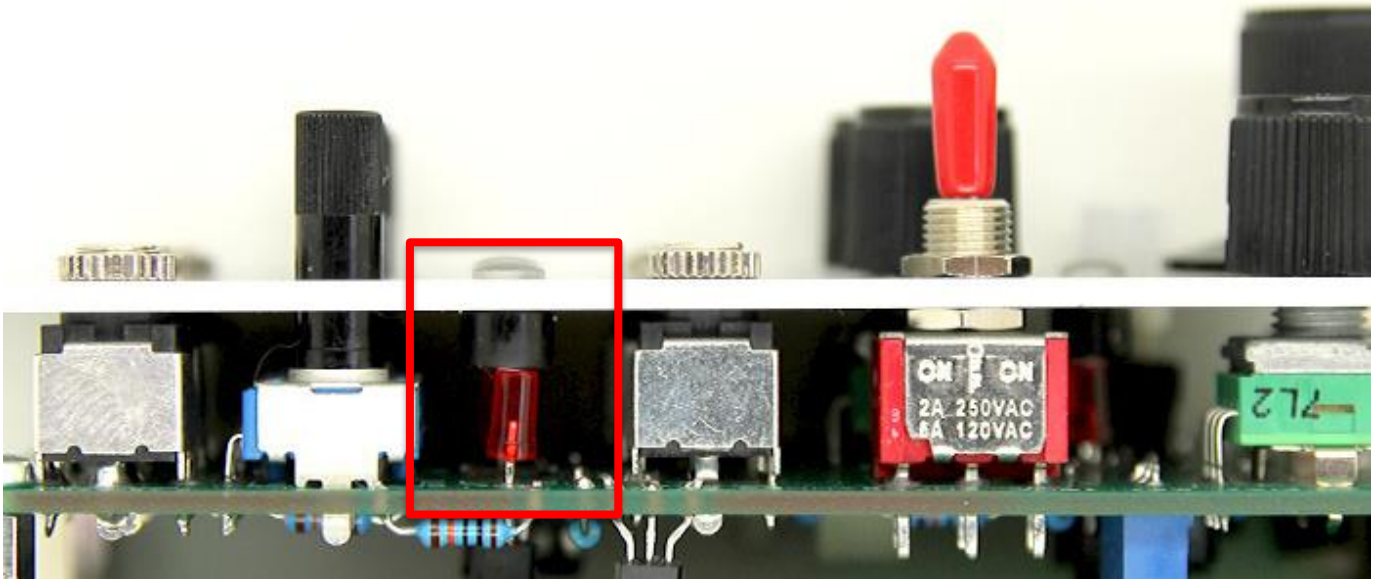

35 – Solder the LEDs in place making sure the LEDs are lined up and touching the light pipes. Check panel components are line up properly and then solder the rest of the component pins.

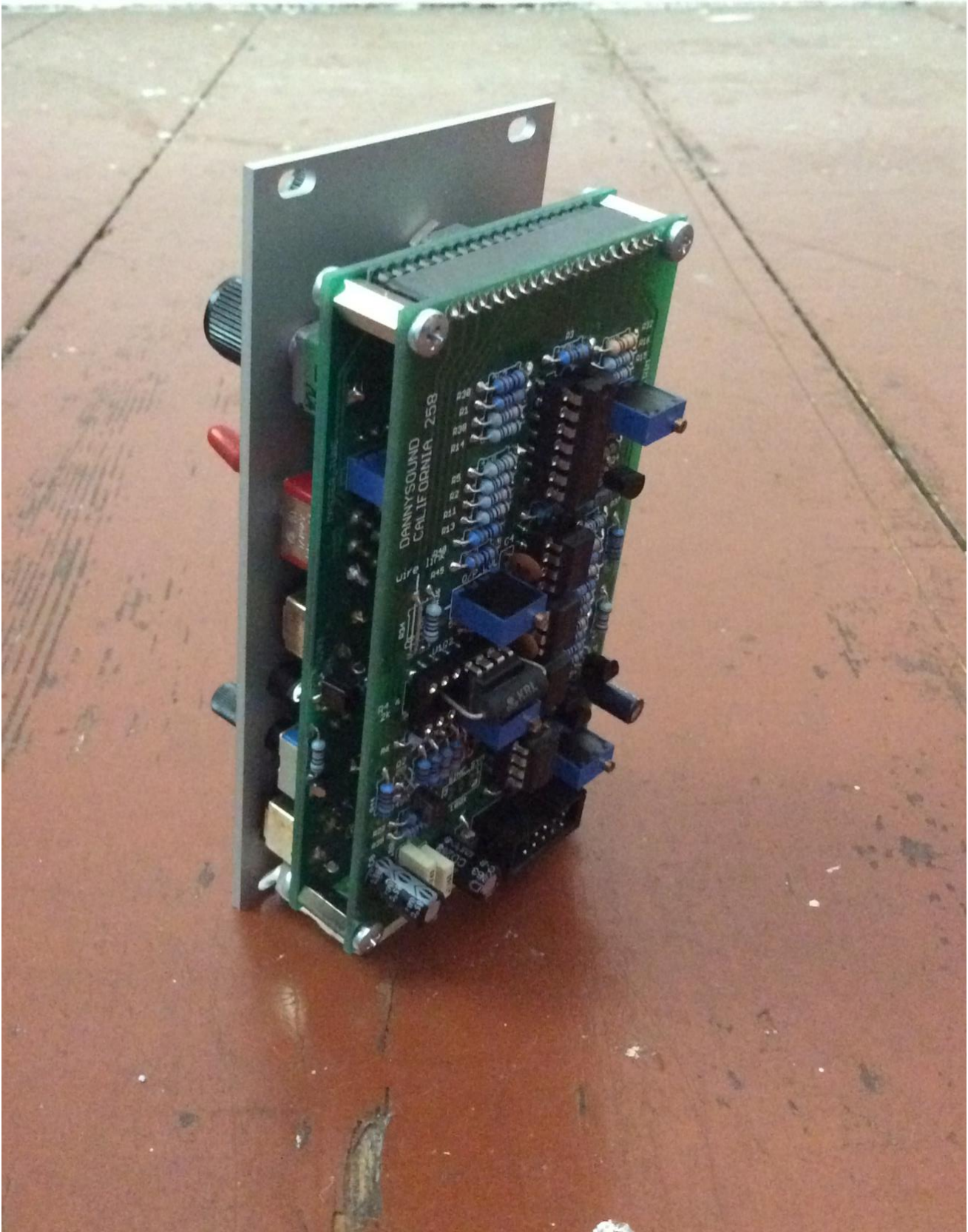

36 - Add PCB mounting hardware, connect the main board and insert the remaining screws.

Calibration



The CALI Oscillator differs from previous versions and clones of the Buchla 258 in that it has a 3-way position switch rather than 2-way. This new middle position features a bonus waveform that will shape from a square into a kind of triangular trapezoid. The wave shaping control is more unpredictable in this middle position – it can be thought of as an extra bonus waveform.

Like all previous versions of the 258 – there is a slight pitch offset between the Square and Triangle output. This is a quirk of the original circuit.

Before you start the calibration procedure make sure the waveform switch is either in it's up or down position, not in the middle.

Wave shaping calibration is visually similar to the J3RK 258J oscillator, a quick video showing that can be found here:

<https://www.youtube.com/watch?v=H4-C41tThqc>

The following calibration procedure was done with the trim pots inserted as in the picture. If your trim pots are inserted the opposite way around to the ones indicated in the picture, then you need reverse the direction in which the trim pot is turned in the calibration procedure.

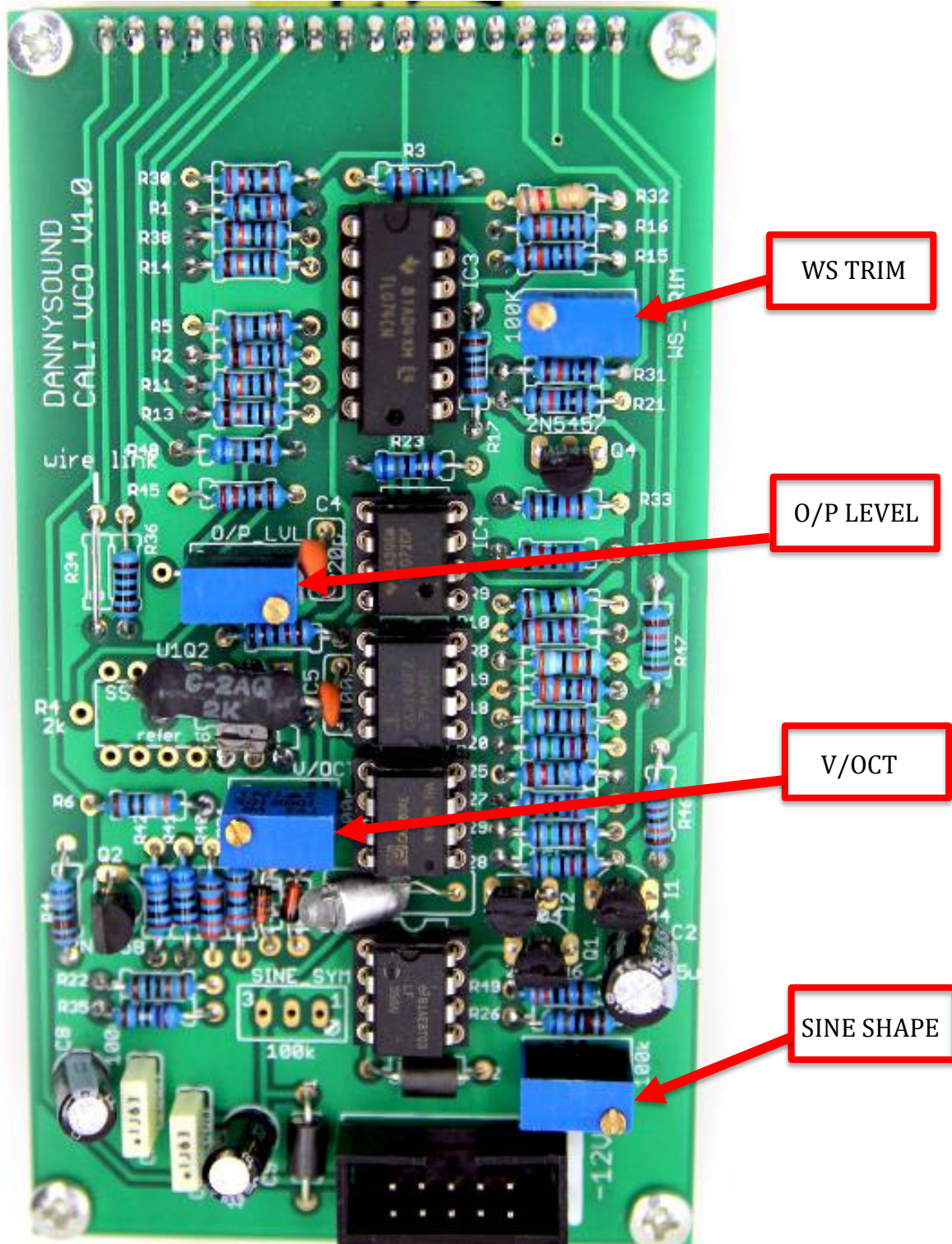

Procedure Using No Measuring Equipment.

- 1 – Set the front panel Frequency control to 50%, ensure that the LFO switch is set to out. Set all other controls to 0. **Ensure the Waveform Switch is set either up or down – not in the middle.**
- 2 – On the Main PCB turn the WS_TRM pot fully anti-clockwise. Be careful not to over turn the trim pot, you should here a click or feel some resistance increase when the end of travel is reached.
- 3 – Turn the SINE_SHAPE trim pot fully anti-clockwise then give it about 8 turns clockwise.
- 4 – Connect the oscillator output to an amplifier. Ensure the volume is set low but audible. You should here a tone, if not adjust the SINE_SHAPE trim pot until a tone is heard.
- 5 – Turn the SINE_SHAPE trim pot anti-clockwise until the tone disappears, then clockwise again until the tone reappears. Carefully listen to the tone and adjust the SINE_SHAPE trim clockwise. You should be able to hear a point where the tone is purest with the least amount of higher harmonics or distortion. This may take few attempts to find the right spot.
- 6 – Turn the WS_TRIM trim pot clockwise until you here the tone start to distort slightly, then back anti-clockwise again about a half turn or so, until you here the clean tone.
- 7 – Connect the pulse output to the amplifier. Adjust O/P LVL until the pulse output becomes inaudible then back half a turn.

If you notice distortion in the sine wave after this procedure, steps 5 and 7 should be repeated to obtain a clean waveform.

Procedure Using Oscilloscope.

- 1 – Set the front panel Frequency control to 50%, ensure that the LFO switch is set to out. Set all other controls to 0. **Ensure the Waveform Switch is set either up or down – not in the middle.**
- 2 – On the Main PCB turn WS_TRIM trim pot fully anti-clockwise. Be careful not to over turn the trim pot, you should here a click or feel some resistance increase when the end of travel is reached.
- 3 – Turn the SINE_SHAPE trim pot fully anti-clockwise then give it about 8 turns clockwise.

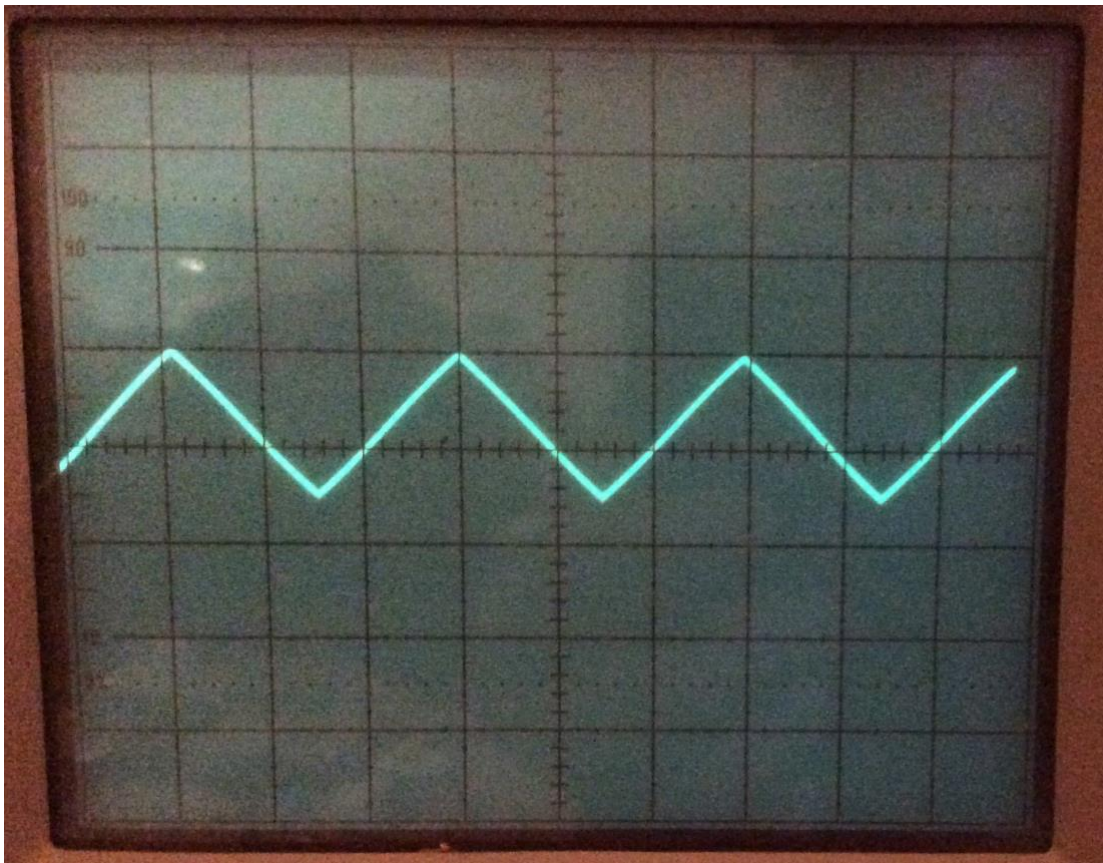

4 – Connect the oscillator output to an oscilloscope. You should see a triangle wave, if not adjust the SINE_SHAPE trim pot until a triangle wave is seen.

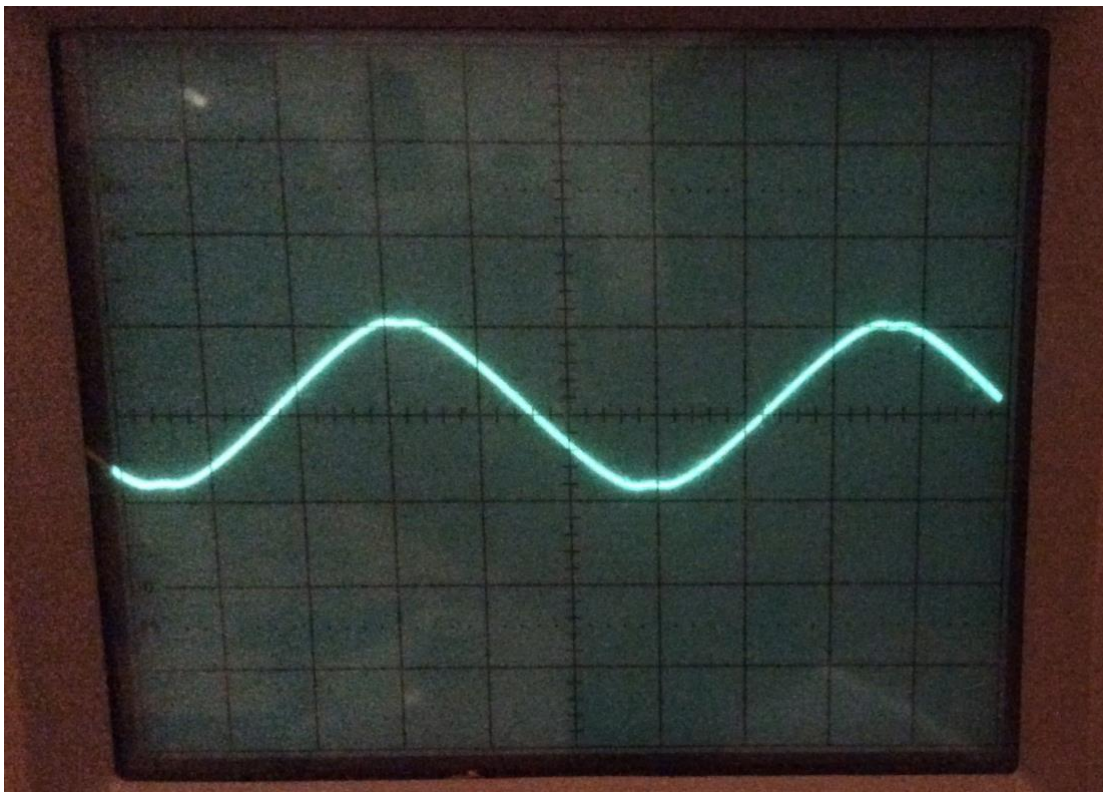

5 – Turn the SINE_SHAPE trim pot anti-clockwise until the signal appears as above, with a slight V shape cutting into to peaks and troughs of the sinewave.

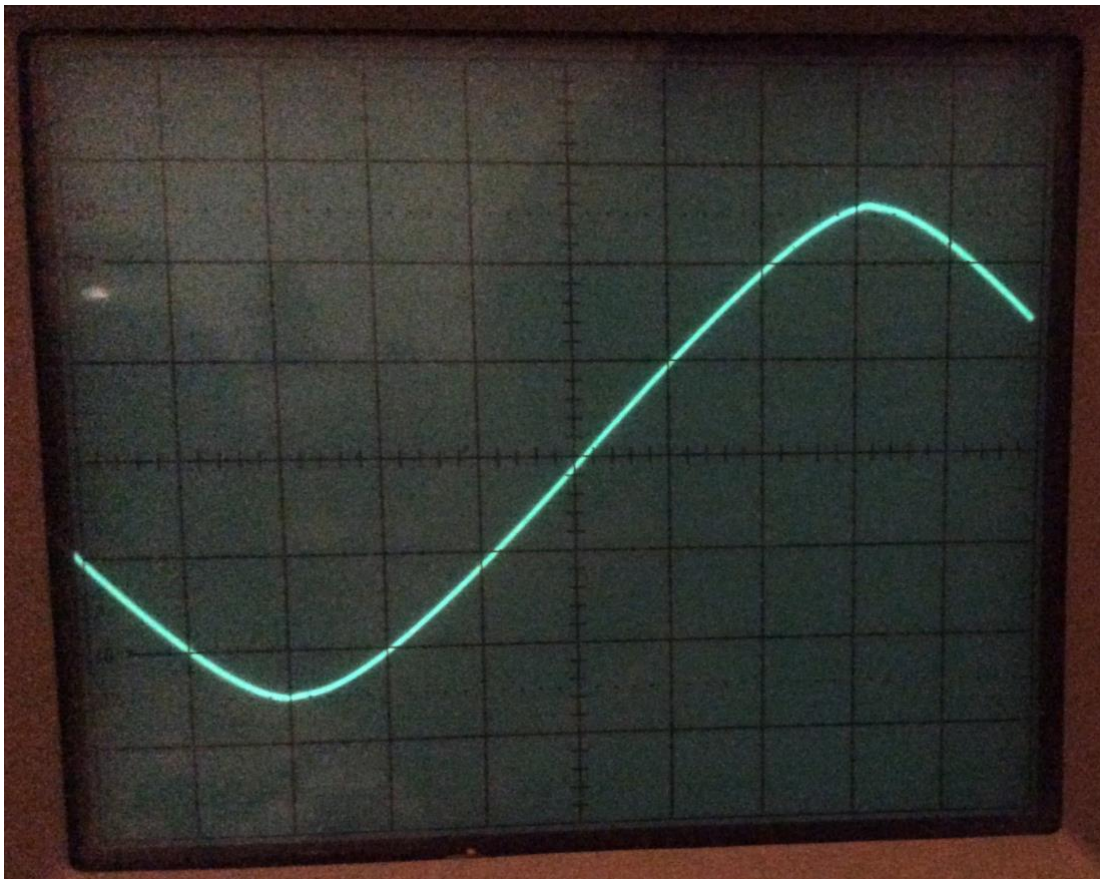

7 - Adjust the SINE_SHAPE trim clockwise a few turns until you see a sine wave.

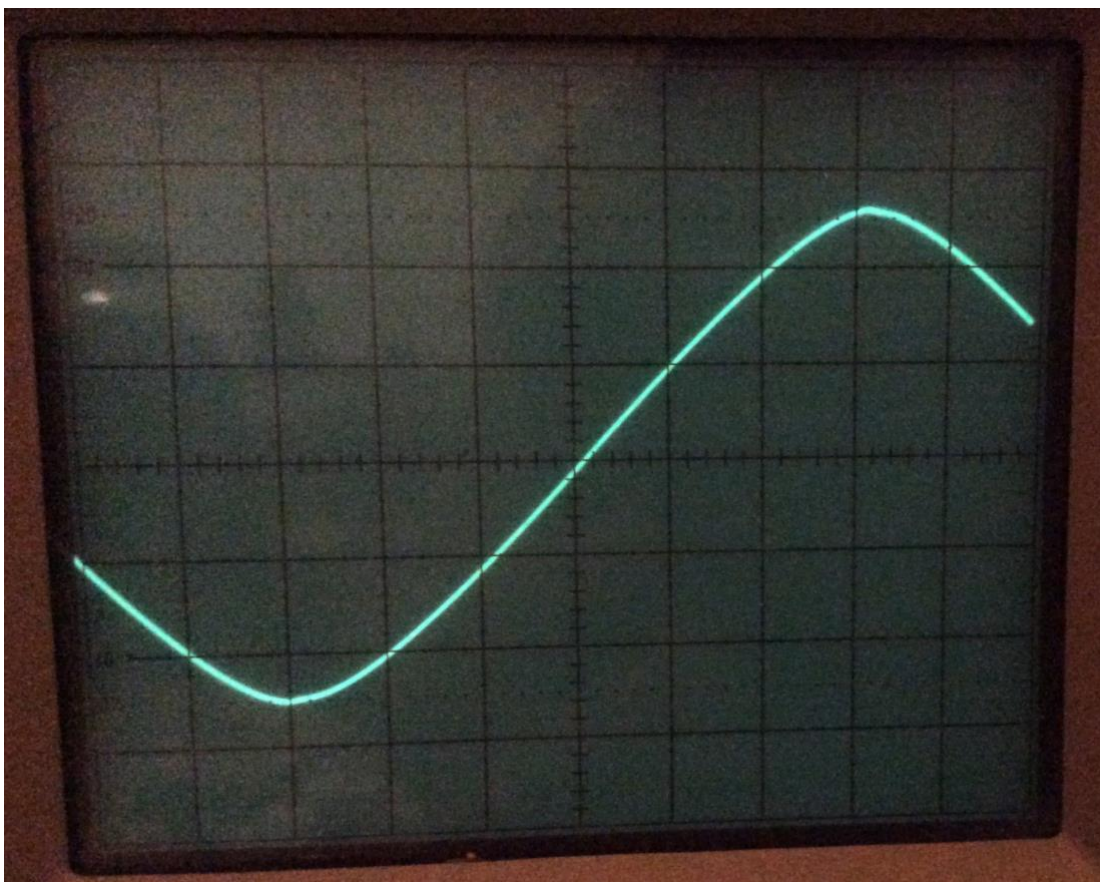

8 - Adjust the O/P_LVL trim pot for a peak to peak value of 10 volts.

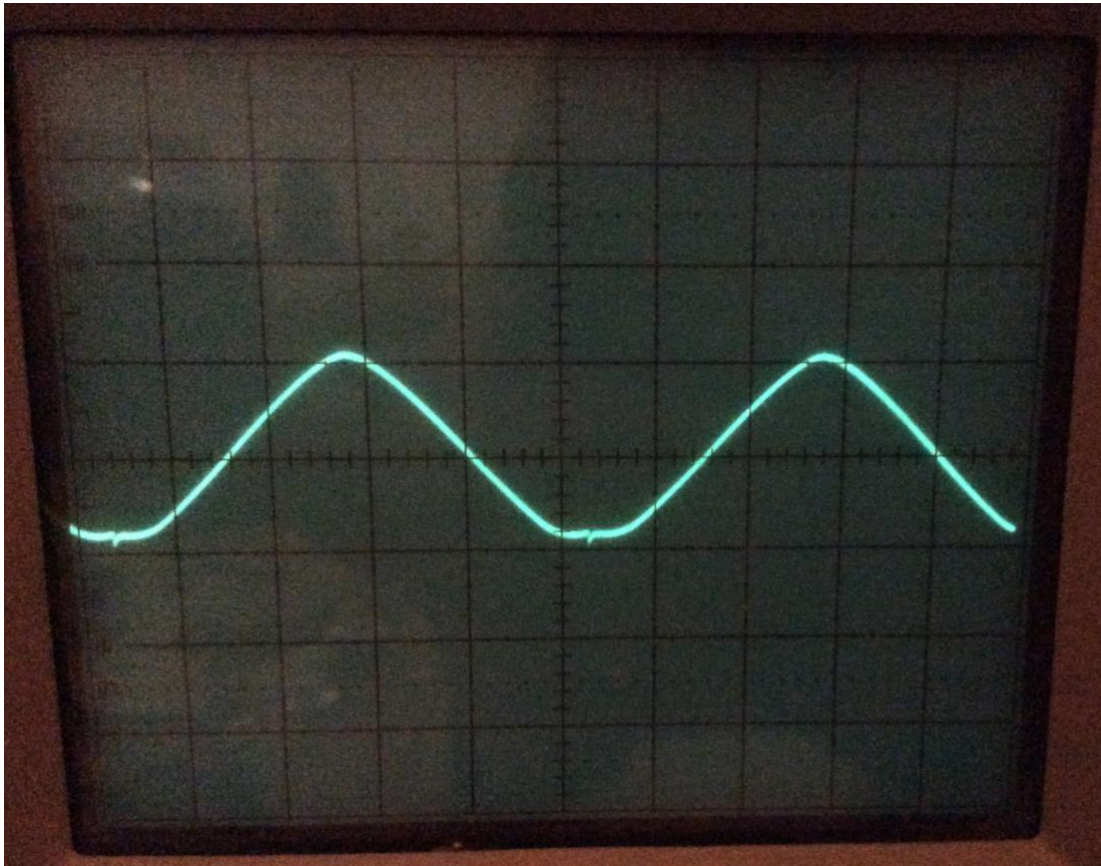

9 – Turn the WS_TRIM trim pot clockwise until you see the trough of the sine wave start to change, then back anti-clockwise again about a half turn or so, until you see the pure sine wave.

V/OCT CALIBRATION

This can be done using a guitar tuner or by listening if you have a good sense of pitch! The procedure uses 3 octaves but it can also be done over 4 or 5 octaves if you wish.

- 1 – Connect voltage source / keyboard to v/oct input.
- 2 – Send 4V (C2) from voltage source / keyboard.
- 3 – Adjust front panel frequency controls to produce note C2
- 4 – Send 7V (C5) from voltage source / keyboard.
- 5 – Adjust V/OCT trim pot and repeat steps 3 to 5 until the interval between the two notes is 3 octaves.
- 6 – Adjust the MASTER TUNE trim pot (if inserted) to set the pitch of the oscillator.

Modifications

All these changes are on the pots board.

A useful modification for systems using note voltages based around 0V is to change R227 to 39k and R222 to 5k6. This gives a wider range on the main frequency control pot.

The LED brightness can be adjusted by changing the values of R213, R223, R210, R214 and R225 for the PWM, LIN FM, LOG FM, WS CV and LFO switch respectively.

Higher resistance = less brightness.

The Range for the main frequency and fine frequency can also be increased or decreased by adjusting the values of R219 and R220 respectively. Higher resistance = more limited range. This mod tends to increase the lower frequency range on the main frequency pot.