

Timbre

Build Guide v1

Dannysound

1 Introduction

2 Construction Tips

3 Parts Lists

4 Outer Board

5 Mid Board

6 Pots Board

7 Panel Components

8 Final Assembly

9 Testing and Calibration

10 Modifications

1 Introduction

The Timbre module is based on the wave folder section of the Buchla 259 oscillator as implemented in the Music Easel.

The wave folder adds harmonics to input signals that have low harmonic content such as Sine and Triangle waves creating rich timbres.

The addition of an extra input to allow 2 oscillators to drive the wave folder dramatically increases the range of possible tones that can be generated.

Features:

Osc1 / Osc2 Mix – Adjusts mix between oscillator 1 and 2 inputs, also acts as an attenuator if only one of the inputs is used.

Timbre – Adjusts the wave fold amount.

Timbre CV – Bipolar (attenuverter) control of Timbre CV.

Symmetry – Adds offset to input so top half of wave starts folding earlier.

Blend – Mixes between clean and effected sound.

Connections:

Inputs

Osc 1

Osc 2

Timbre CV

Symmetry CV

Blend CV

Output

1 x Output.

2 Construction Tips

These tools come in very handy, especially if you do a lot of DIY projects. They should be available from most electronics hobbyist stores.

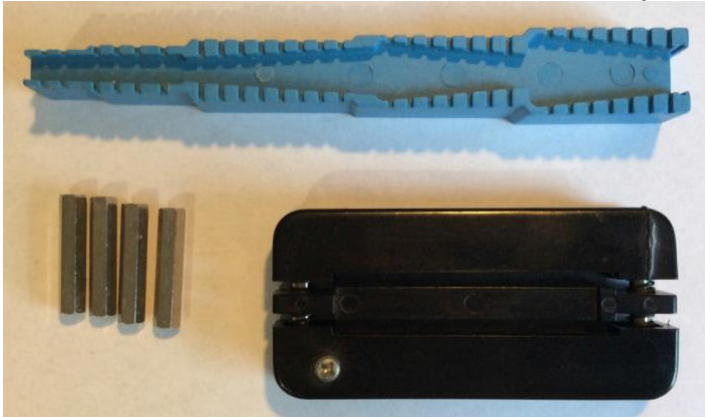

The blue bending gauge is for bending the resistor and diode legs to the right size. The black IC straightener is for straightening pins of op-amps etc. The silver standoffs are 25mm Female to Female.

You can use this setup with the 25mm standoffs for inserting the resistors and diodes.

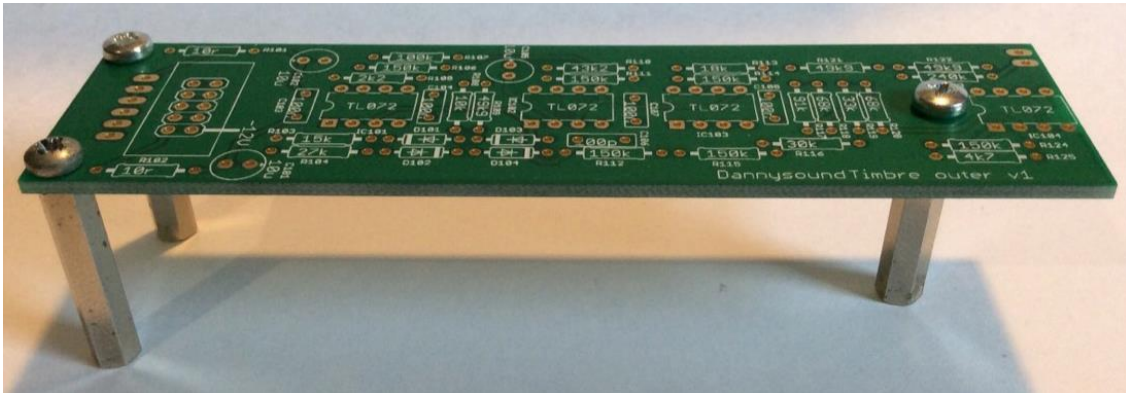

It has the advantage of being much quicker to place all the resistors etc and it's easy to fix any mistakes. You can then solder everything from the top in one go (make sure you have decent temp. solder iron with not too fat tip!).

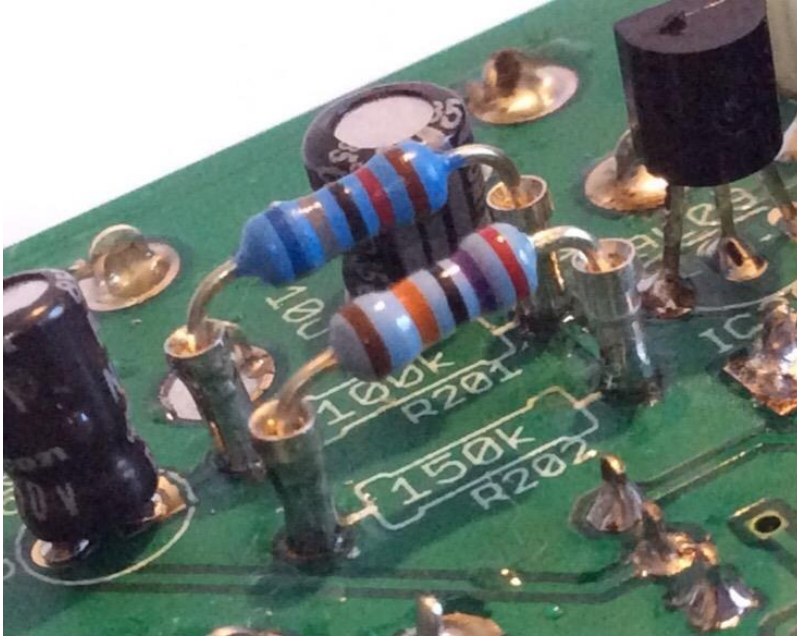

Cutting the pins from a SIL connector and soldering as shown above is useful for experimenting with different component values if you want to try out any of the modifications.

Note though that the Think kit contains all the parts you'll need for a well-functioning build, chosen to give you what we think is the best place to start.

3 Parts Lists

TIMBRE OUTER BOARD

RESISTORS		
150k	6	R106 R111 R112 R114 R115 R124
10r	2	R101 R102
2K2	1	R105
4K7	1	R125
10K	1	R108
15K	1	R103
18K	1	R113
27K	1	R104
30K	1	R116
33K	1	R119
68K	2	R118 R120
43K2	1	R110
49K9	3	R109 R121 R122
91K	1	R117
100K	1	R107
240K	1	R123

CAPS		
100n polyester box - 5mm pitch leads	4	C103 C104 C107 C108
100p ceramic	1	C106
10u electrolytic	3	C101 C102 C105

DIODES		
1N4148	4	D101 D102 D103 D104

OPAMPS		
TL072	4	IC101 IC102 IC103 IC104

SOCKETS		
8 pin DIL socket	4	

HEADERS		
1 X 6 FEMALE	1	
1 X 2 FEMALE	1	
Shrouded 2 x 5 power socket	1	

TIMBRE MID BOARD

RESISTORS		
220r	1	R208

1k	2	R207 R209
3k3	1	R221
4k7	3	R203 R211 R212
10k	4	R204 R218 R226 R206
22k	1	R210
33k	1	R213
39k	1	R220
47k	1	R217
68k	3	R202 R216 R222
150k	1	R219
100k	4	R205 R223 R224 R227
130k	1	R225
300k	1	R201
820K	1	R215
910K	1	R214
CAPS		
100n polyester box - 5mm pitch leads	2	C201 C203
470p ceramic	1	C202
DIODES		
1N4148	1	D201
TRIM POTS		
100k SIDE ADJUST	1	IN LEVEL
20k SIDE ADJUST	1	RANGE
OPAMPS		
TL072	2	IC201 IC203
TL074	1	IC202
VACTROLS		
VTL5C3	2	LDR201 LDR202
SOCKETS		
8 pin DIL socket	2	
14 pin DIL socket	1	
TRANSISTORS		
2N3819	2	Q203 Q204
BC547	2	Q201 Q202
HEADERS		
1 X 6 MALE	1	
1 X 6 FEMALE	2	
1 X 2 MALE	1	

TIMBRE POTS BOARD

RESISTORS		
1k	1	R307
2k2	1	R306
100k	3	R301 R303 R305
150k	3	R304 R302 R310

180k	1	R308
1M	2	R309 R311

SOCKETS		
8 pin DIL socket	1	

OPAMPS		
TL072	1	IC301

TRANSISTORS		
2N3906	1	Q301

HEADERS		
1 X 6 MALE	2	

POTS		
ALPHA 10k LIN	1	TIMBRE
ALPHA 10k LIN CENTRE DETENT	1	TIMBRE CV
TALL TRIMMERS 10K LIN	3	BLEND SYM OSC MIX

LEDS		
RED FLAT TOP	2	BLEND SYM

JACK SOCKETS		
PJ301	6	BLEND SYM TIMBRE OSC1 OSC2 OUT

TIMBRE HARDWARE		
-----------------	--	--

STANDOFFS		
M3 MALE-FEMALE 12MM	3	
M3 FEMALE 11MM	3	

SCREWS		
M3	6	

KNOBS		
ROGAN SKIRT SMALL	1	
ROGAN SMALL	1	

LIGHTPIPES		
5mm	2	

4 - Outer Board

Resistors

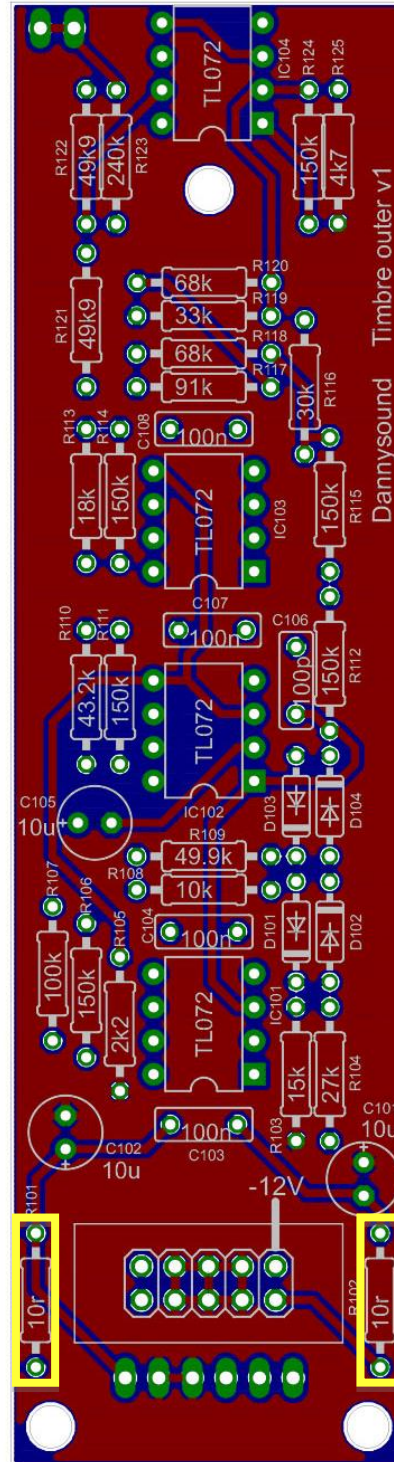
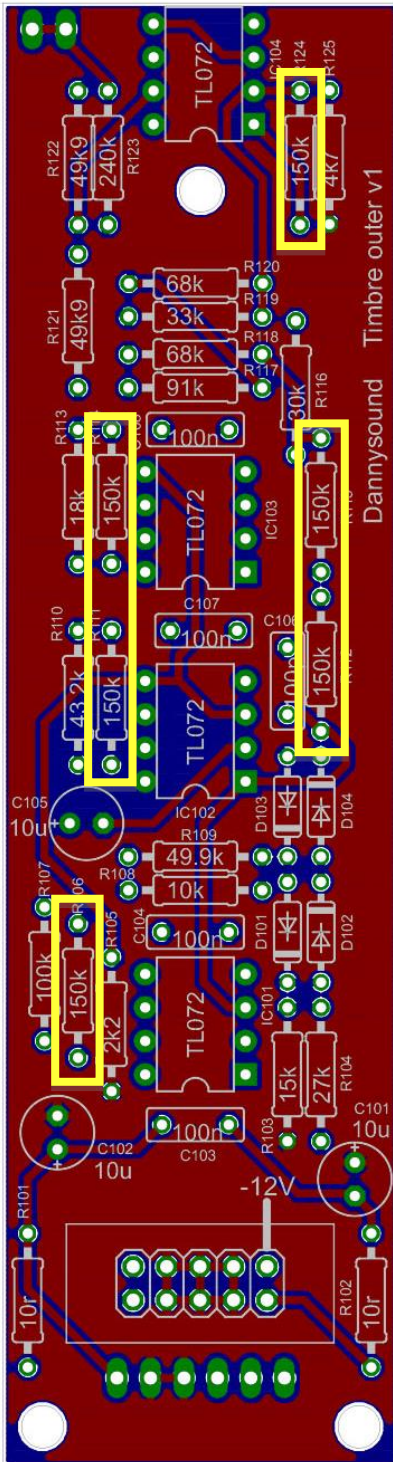

1 - 6 x 150k
(R106, R111, R112, R114, R115, R124)

2 - 2 x 10r (R101, R102)

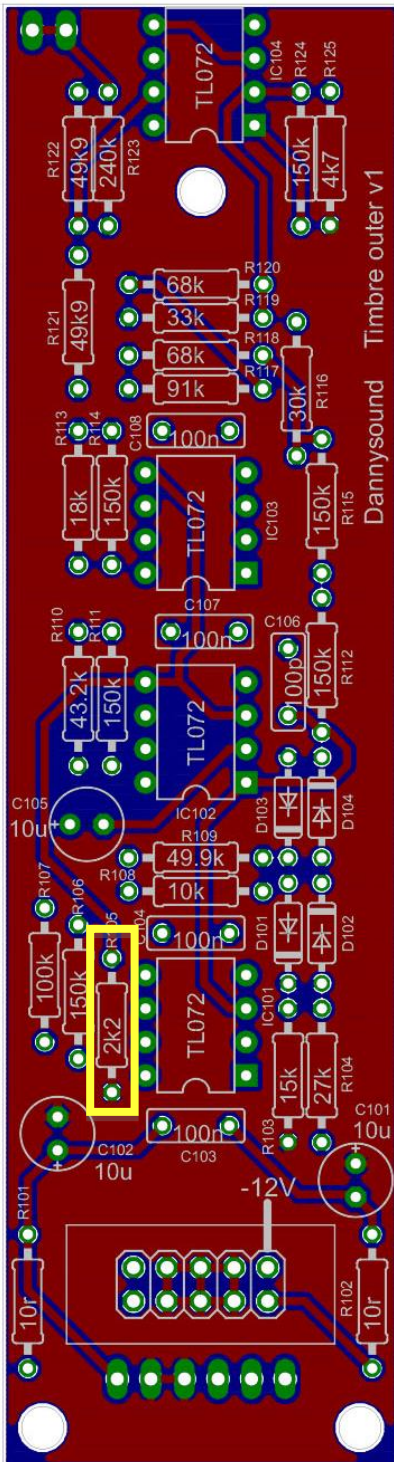

3 - 1 x 2k2 (R105)

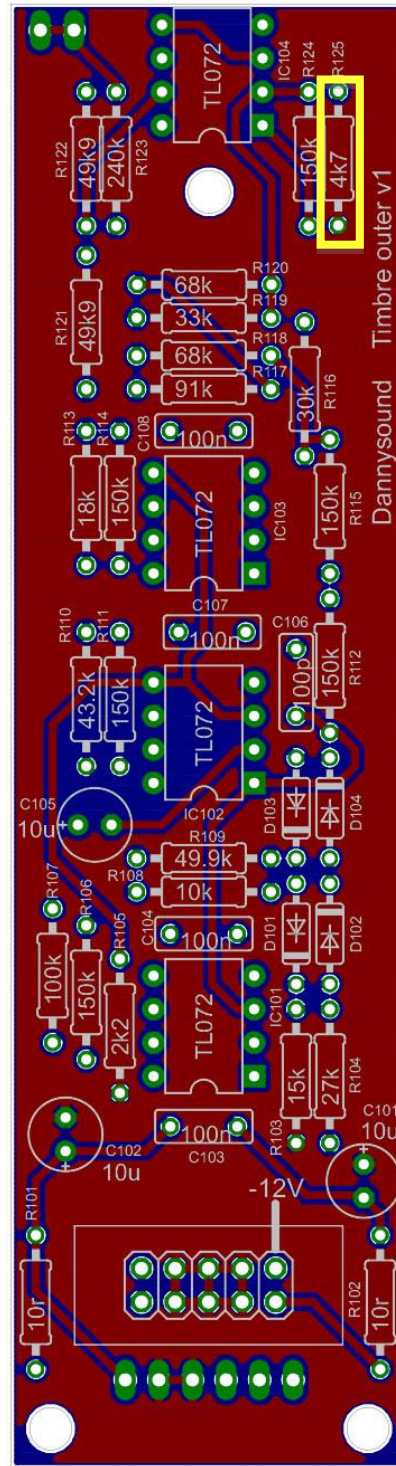

4 - 1 x 4k7 (R125)

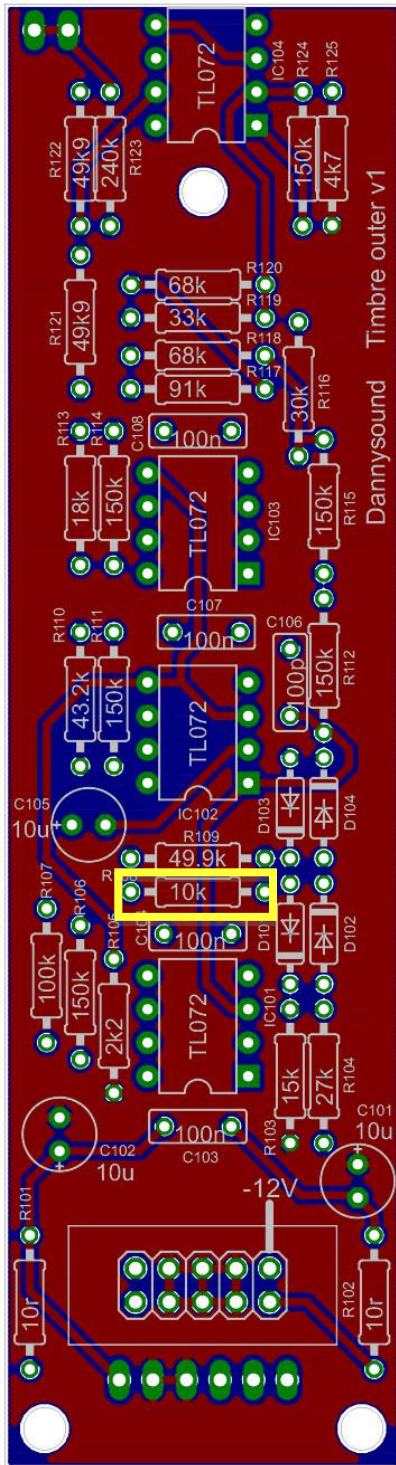

5 - 1 x 10k (R108)

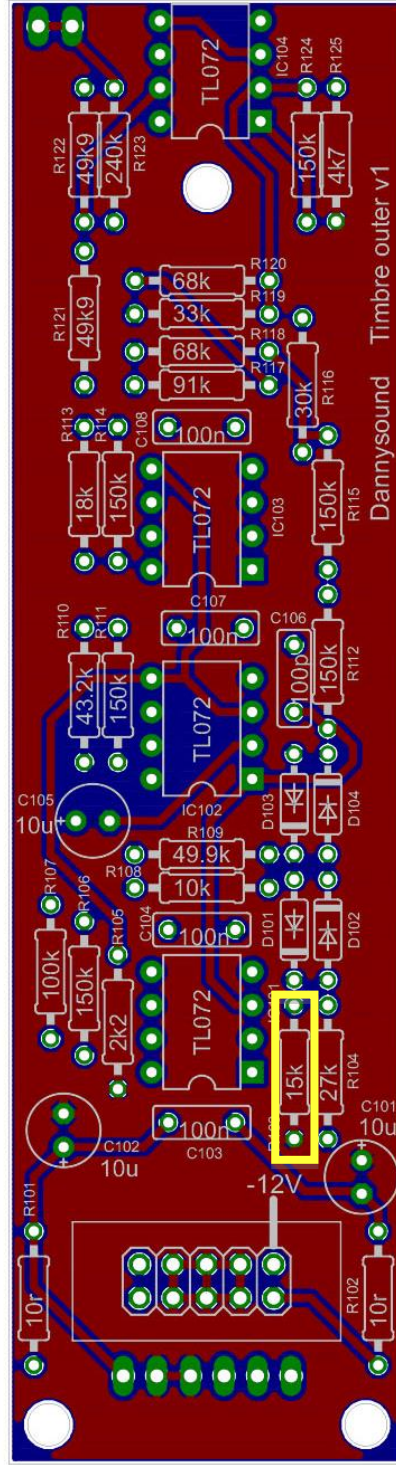

6 - 1 x 15k (R103)

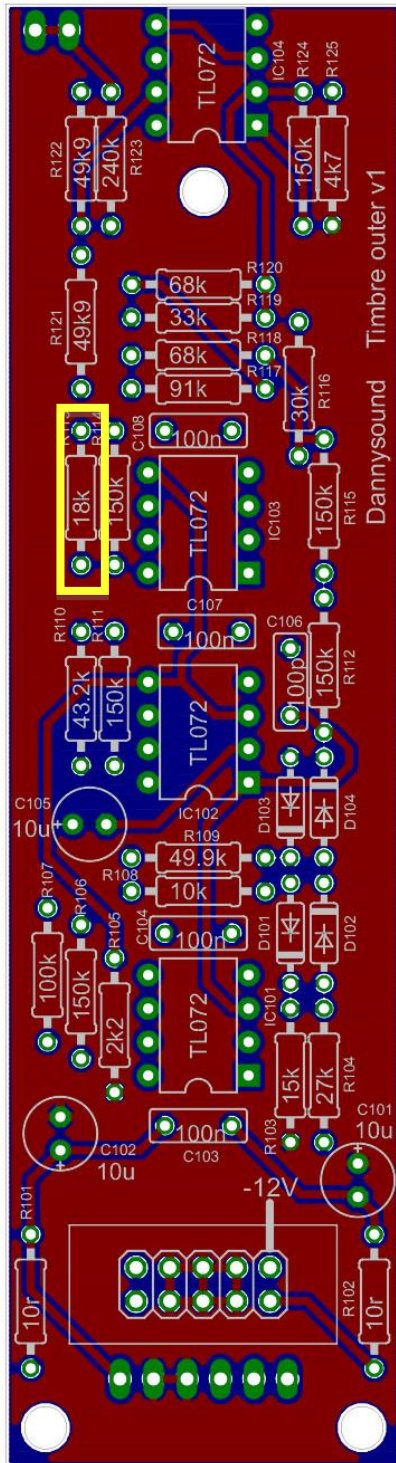

7 - 1 x 18k (R113)

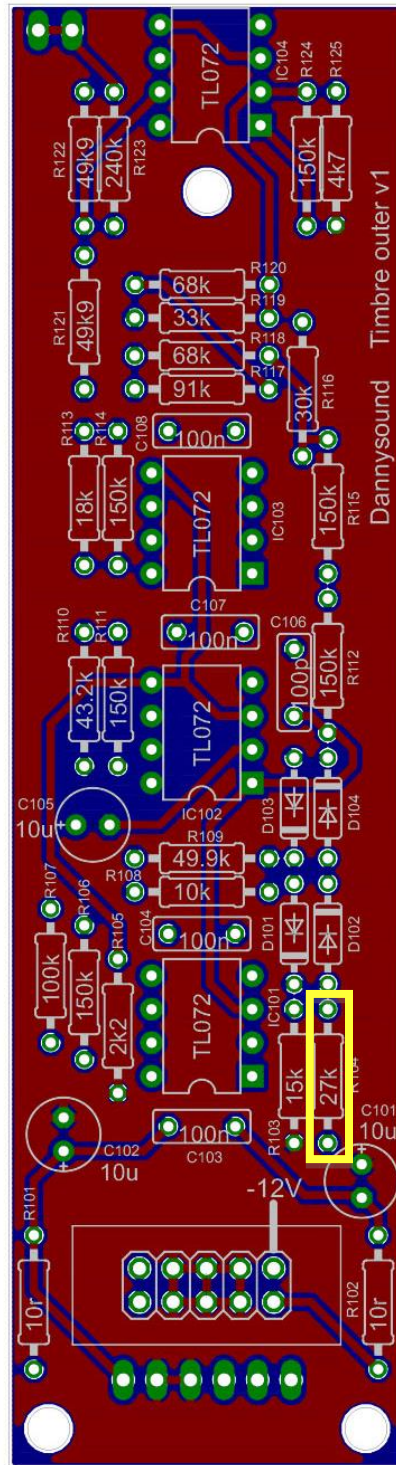

8 - 1 x 27k (R104)

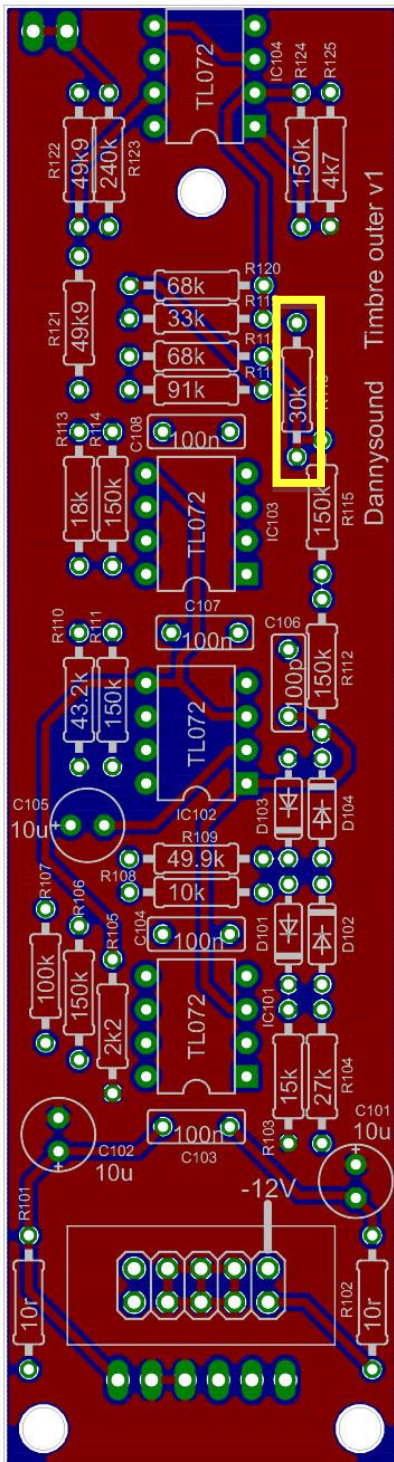

9 - 1 x 30k (R116)

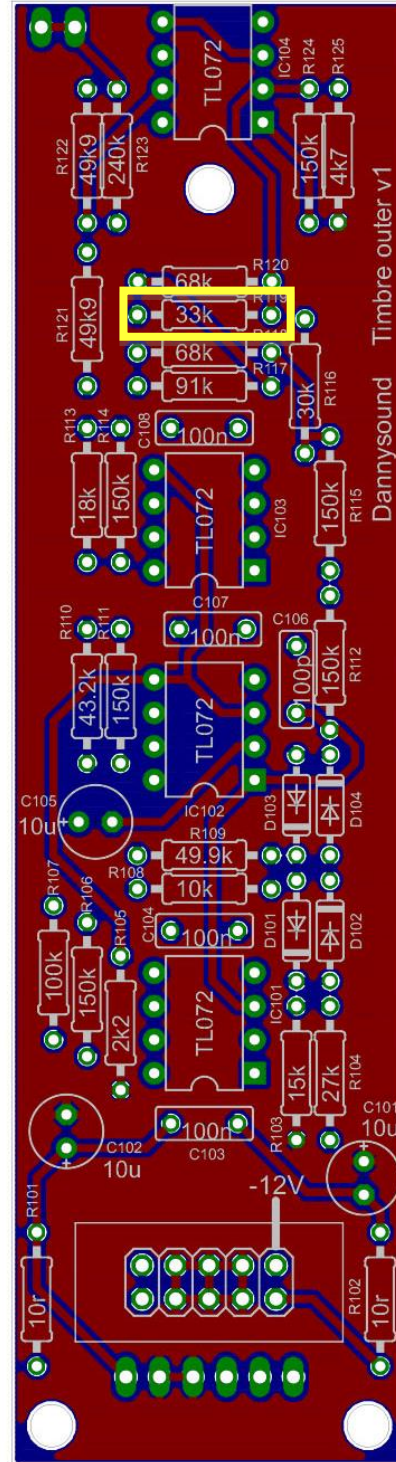

10 - 1 x 33k (R119)

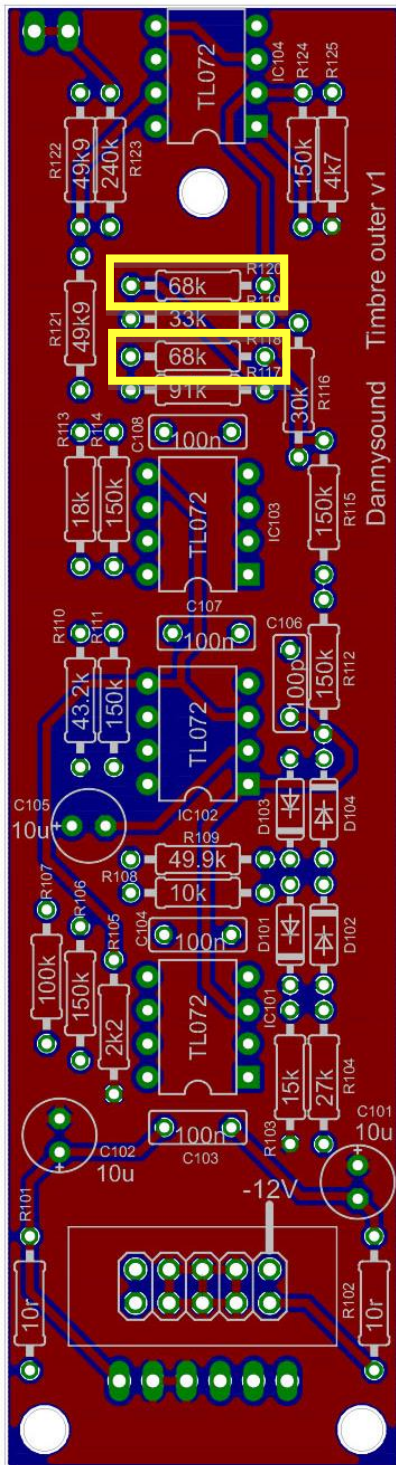

11 - 2 x 68k (R118, R120)

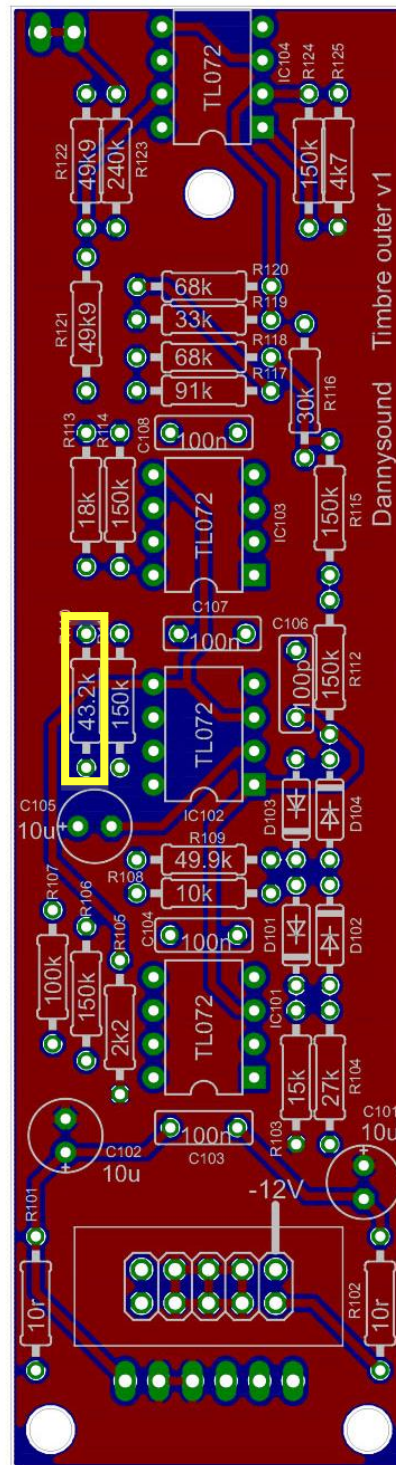

12 - 1 x 43k2 (R110)

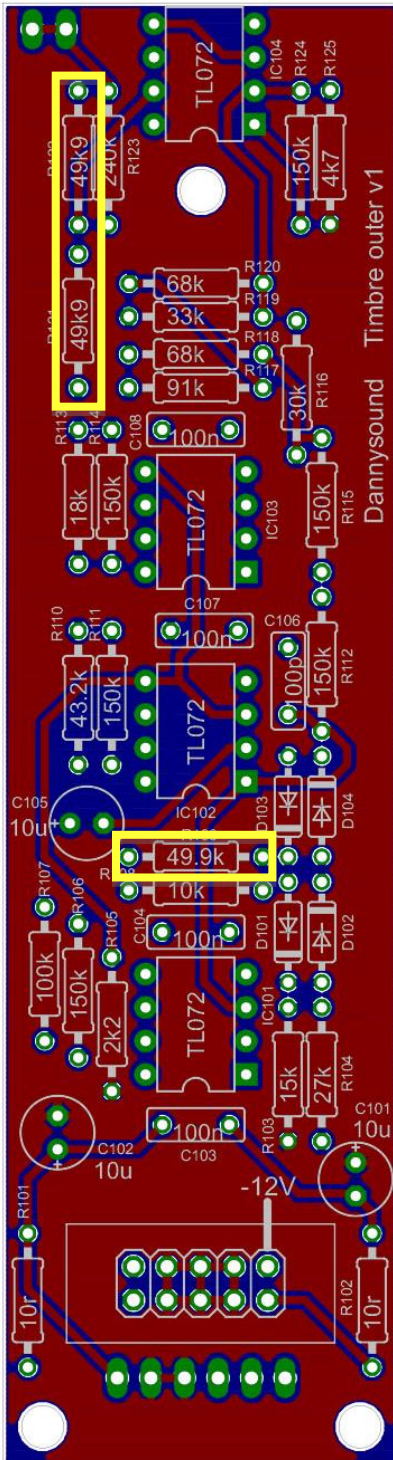

13 - 3 x 49k9 (R109, R121, R122)

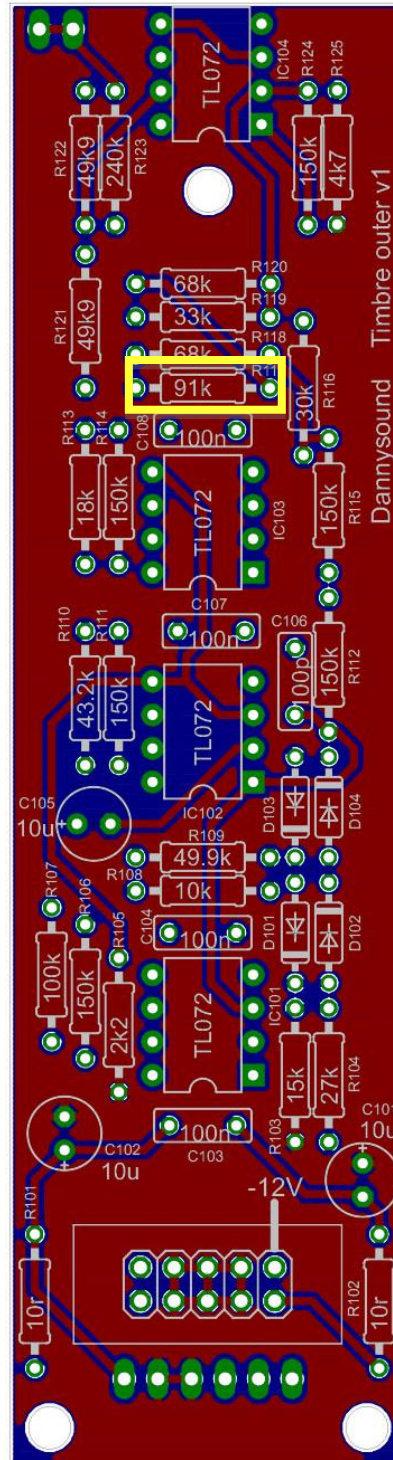

14 - 1 x 91k (R117)

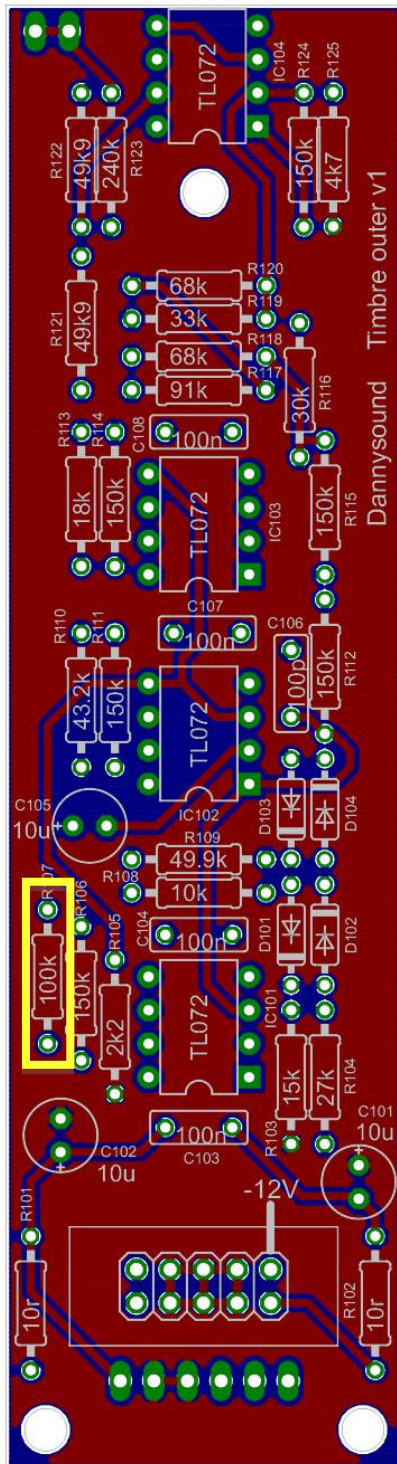

15 - 1 x 100k (R107)

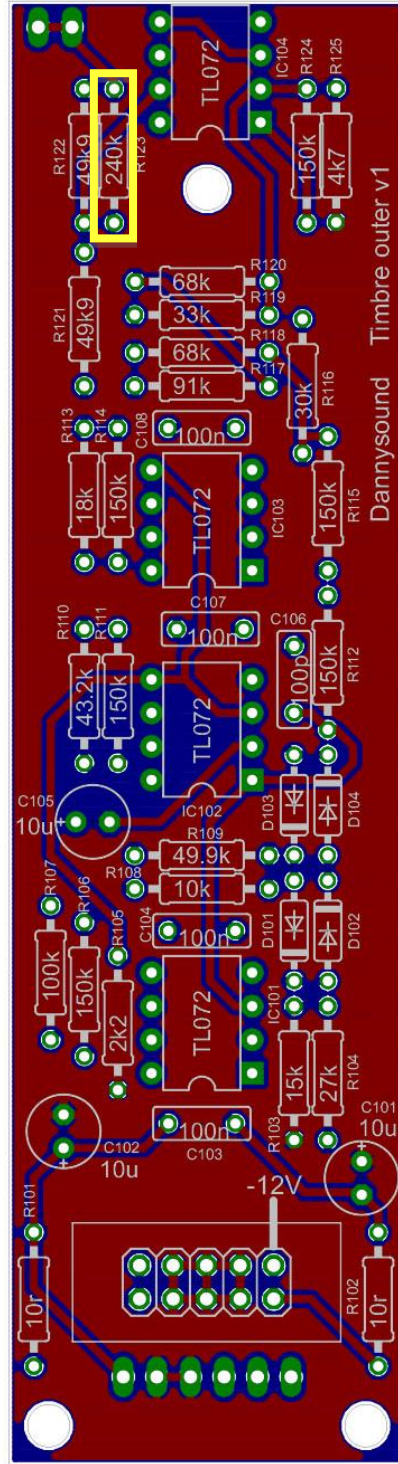

16 - 1 x 240k (R123)

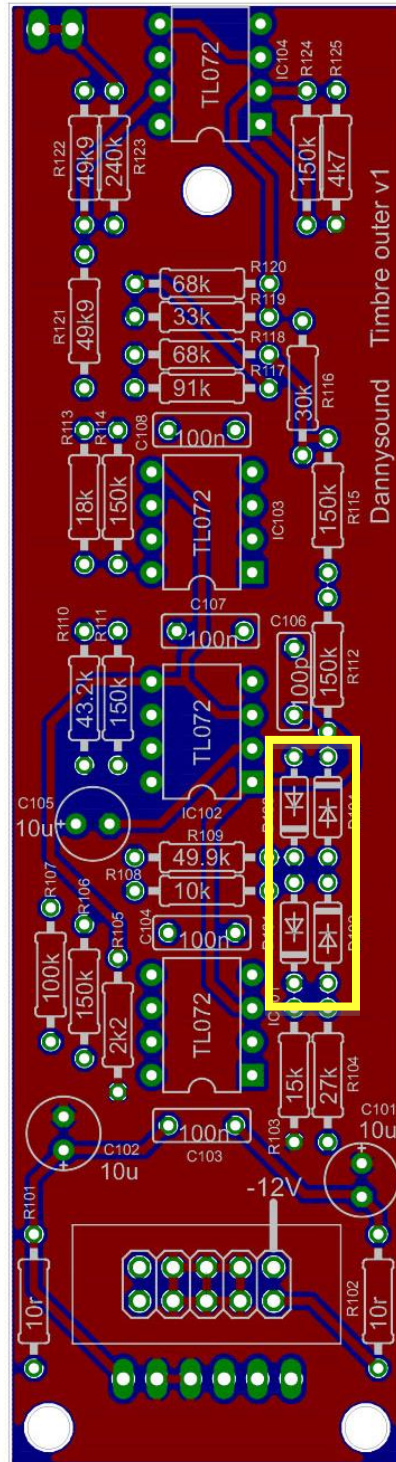

17 - 4 x 1N4148 (D101, D102, D103, D104)

Note: orientation of this part is vital - be sure to match the line on the component with that on the PCB silkscreen

OPAMP SOCKETS

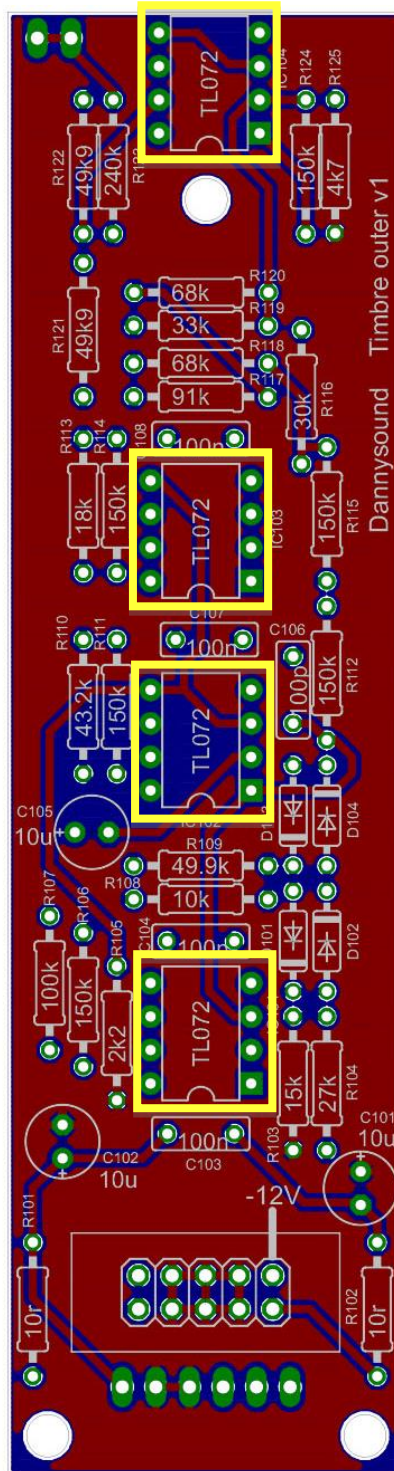

18 - 4 x 8 pin IC sockets - make sure the notches on each socket match the notches on the PCB silkscreen.

CAPACITORS

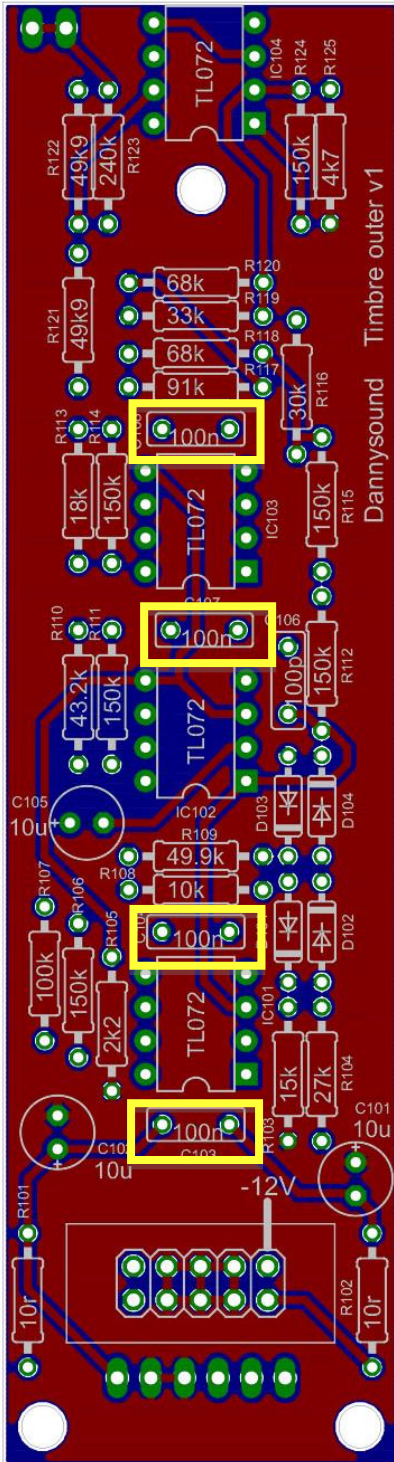

19 - 4 x 100n (C103, C104, C107)

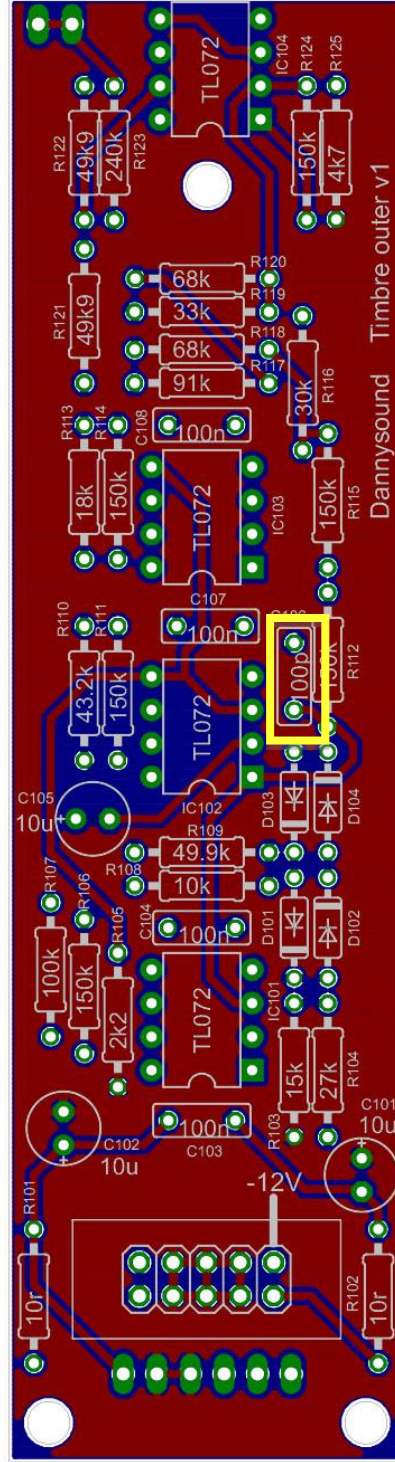

20 - 1 x 100p (C106)

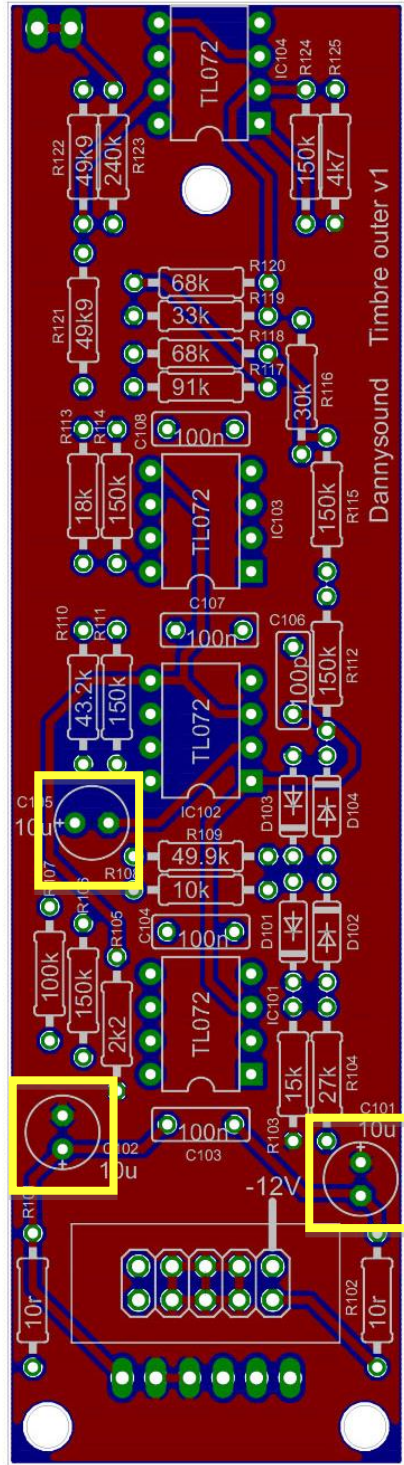

21 - 3 x 10u (C101, C102, C105) - orientation is vital, the longer lead on the component should go to the pad marked with a plus '+' on the PCB. Note the component has a grey stripe on the cylindrical body on the minus side.

OPAMPS

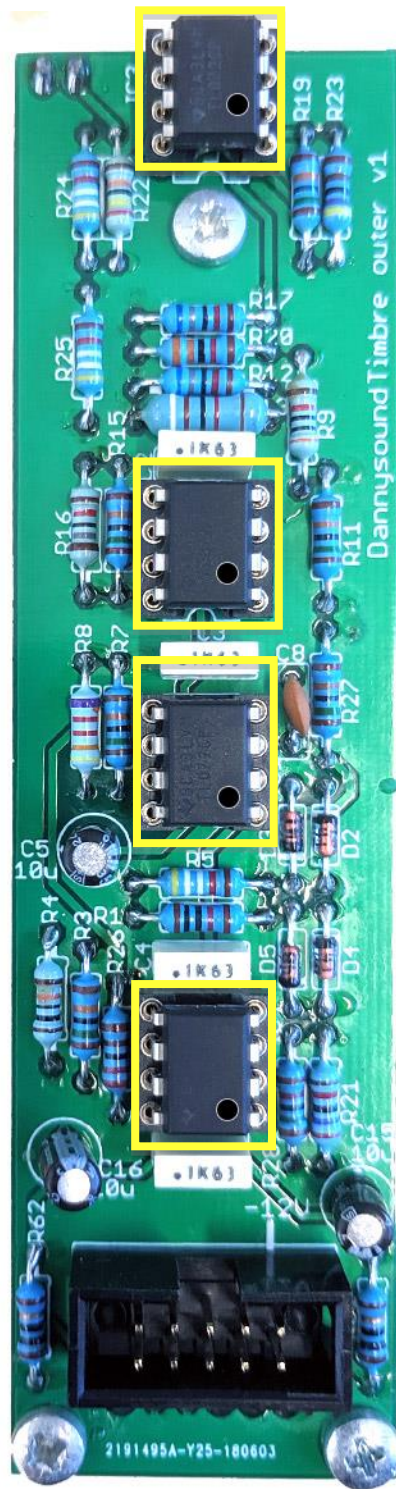

22 - 4 x TL072 opamps - orientation is vital, for these opamps match the dot with the notch on the PCB silkscreen and IC Socket.

HEADERS

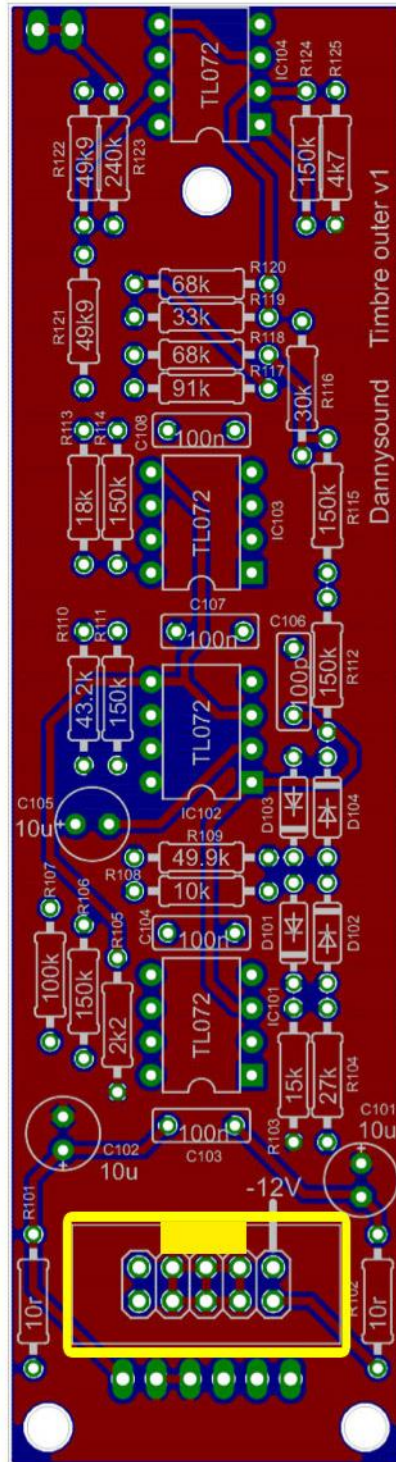

23 - 2x5 shrouded power header - **make sure the slot is facing away** from the edge of the PCB as indicated above. Orientation is vital!

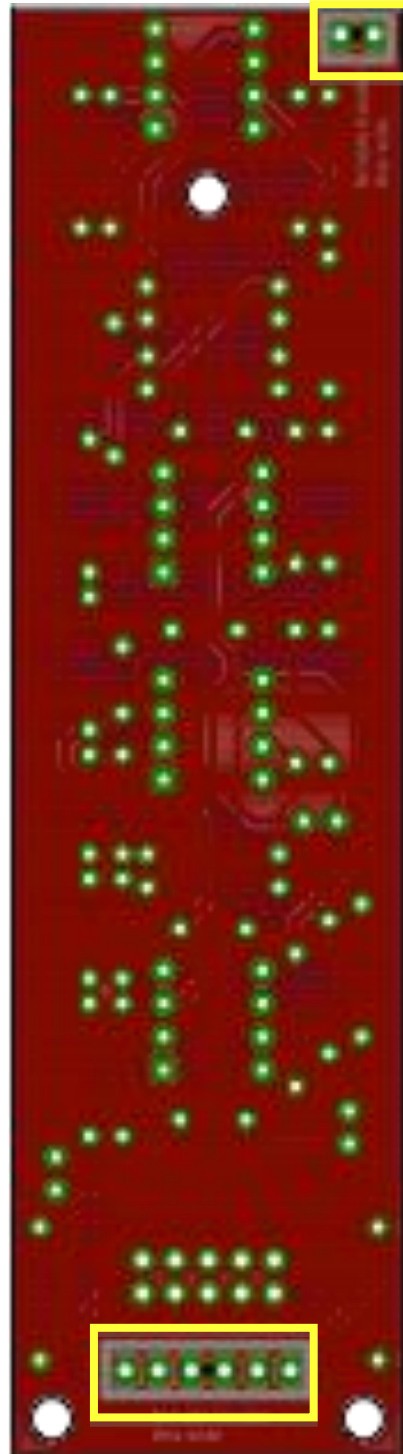

24 - 1x6 pin and 1x2 pin female pin headers

NOTE! These headers are placed on the **opposite side** of all the other components on this PCB!

5 - Mid Board RESISTORS

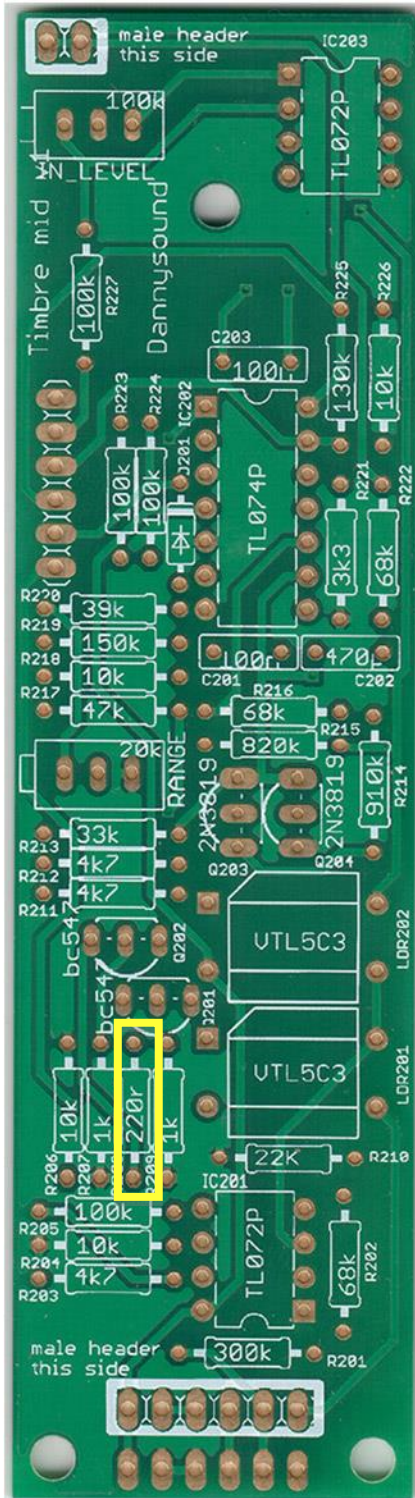

25 - 1 X 220r (R208)

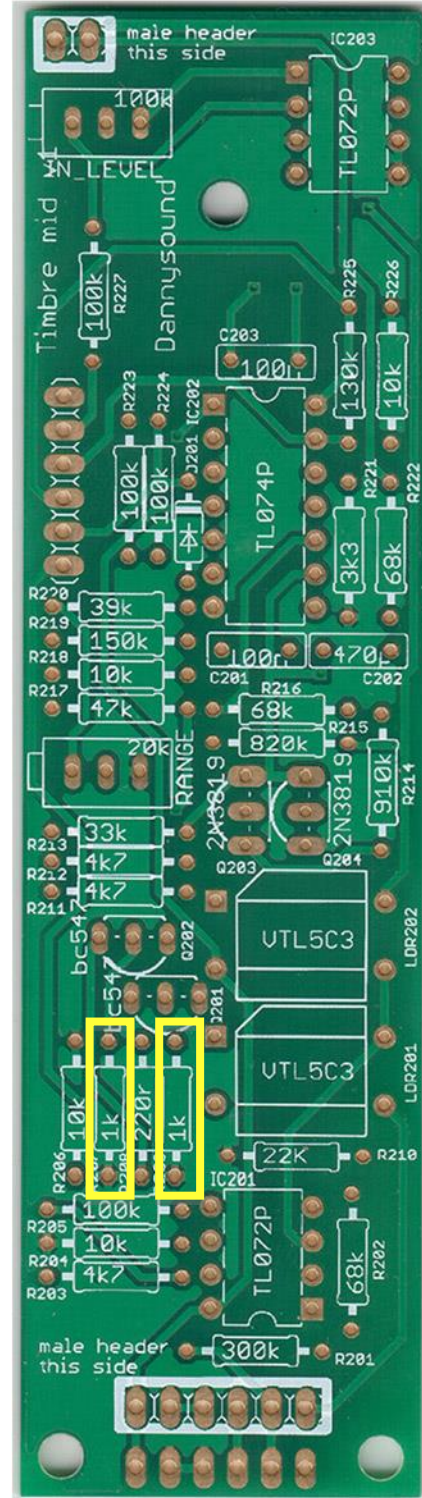

26 - 2 x 1k (R207, R209)

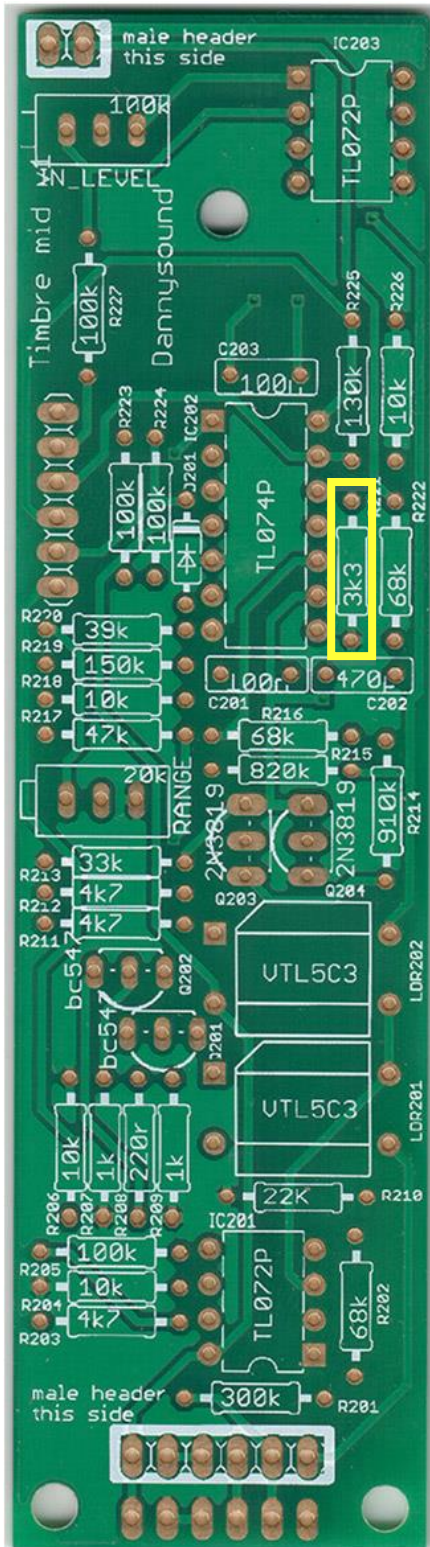

27 - 1 X 3k3 (R221)

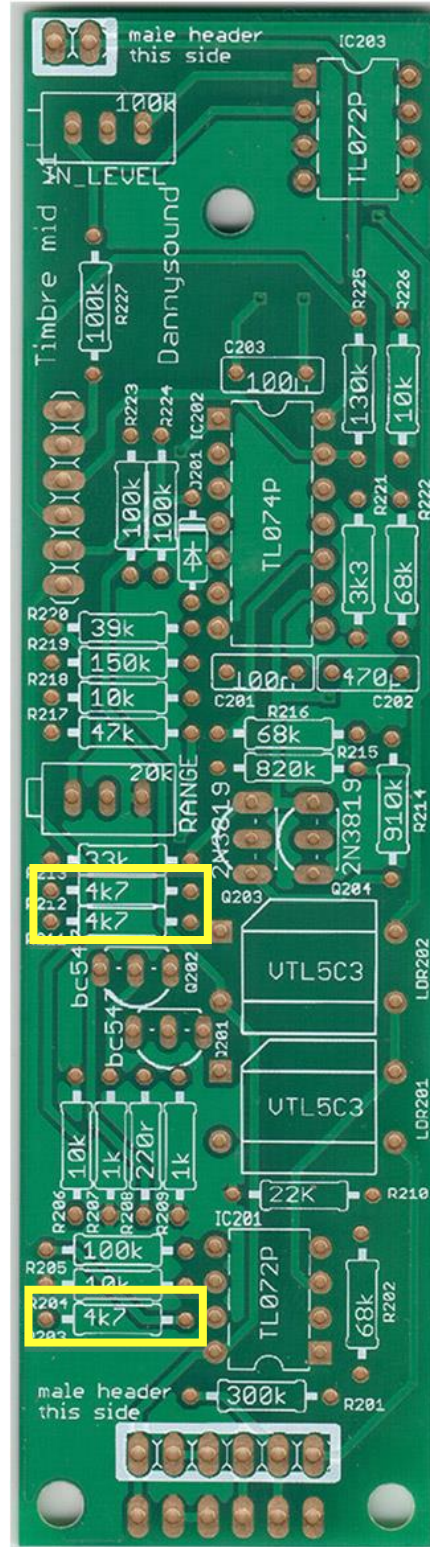

28 - 3 x 4k7 (R203, R211, R212)

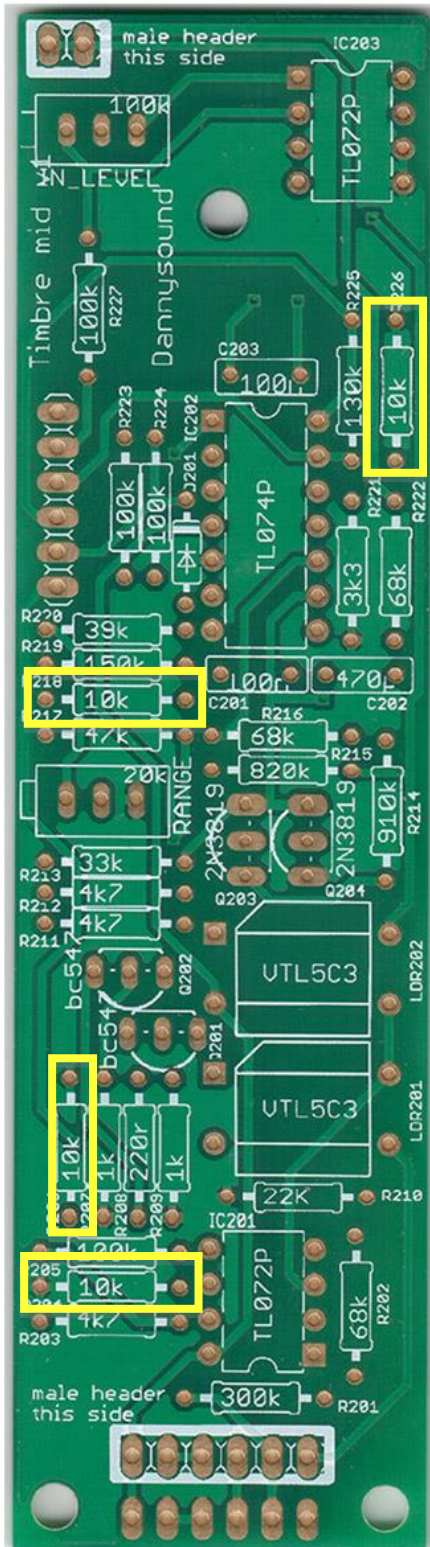

29 - 4 x 10k (R204, R206, R218, R226)

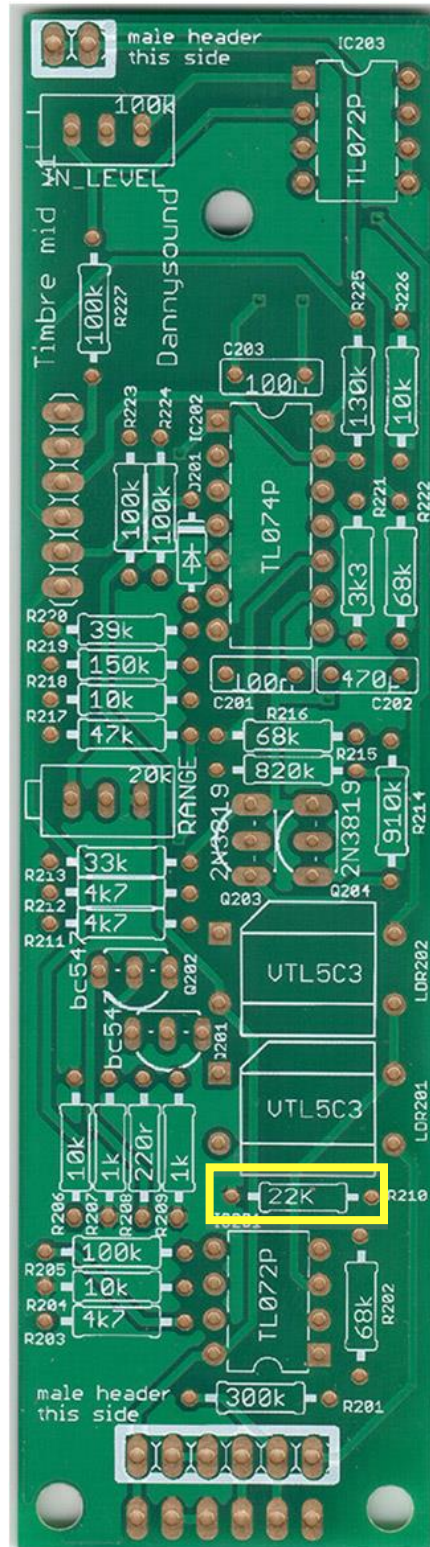

30 - 1 x 22k (R210)

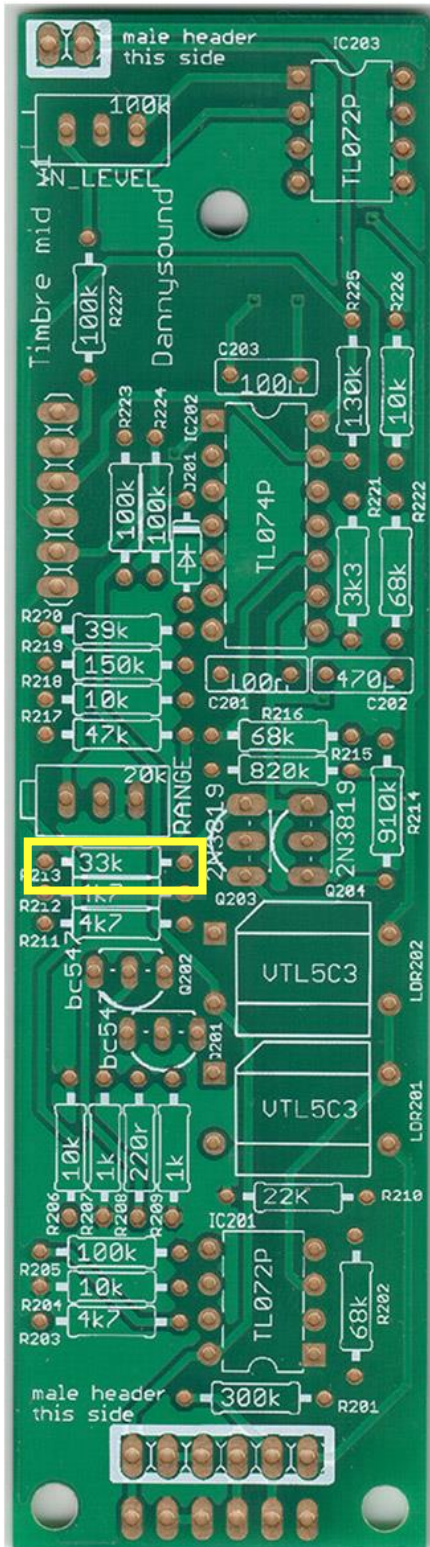

31 - 1 x 33k (R213)

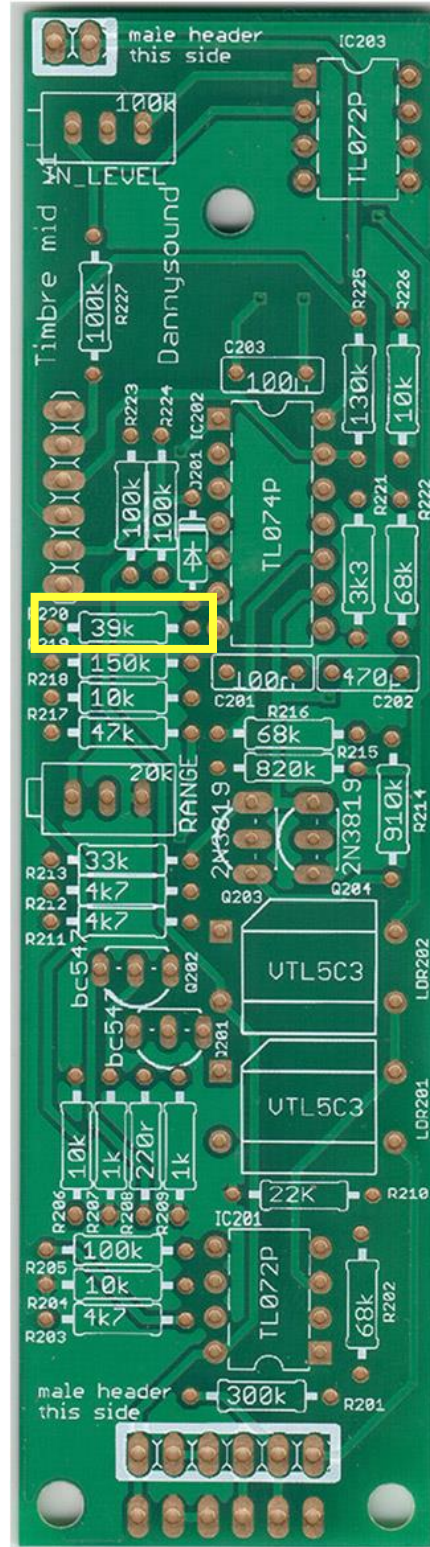

32 - 1 x 39k (R220)

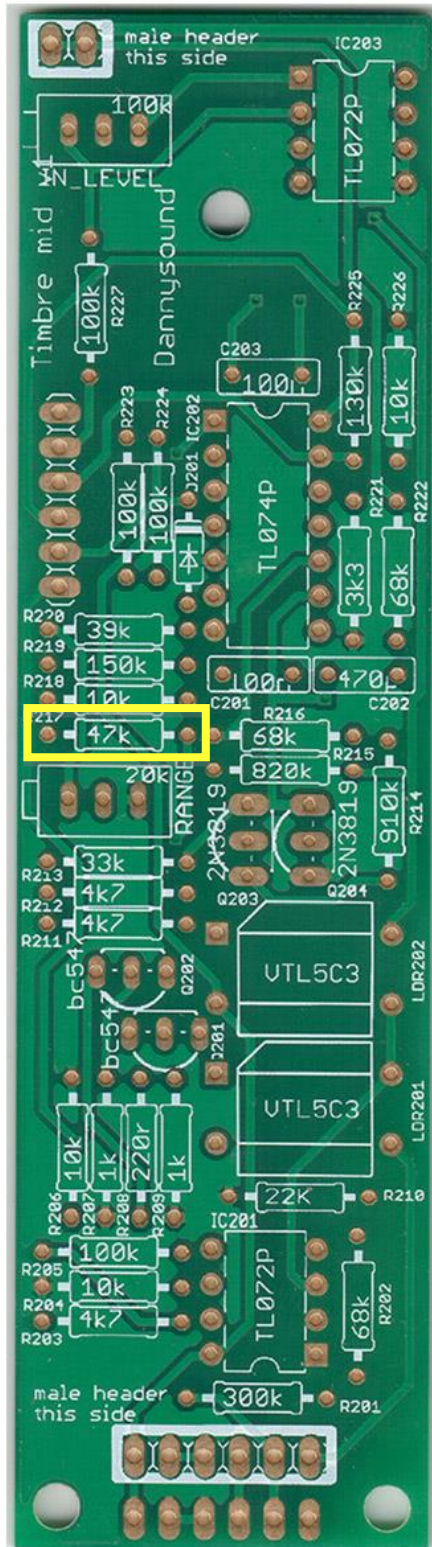

33 - 1 X 47k (R217)

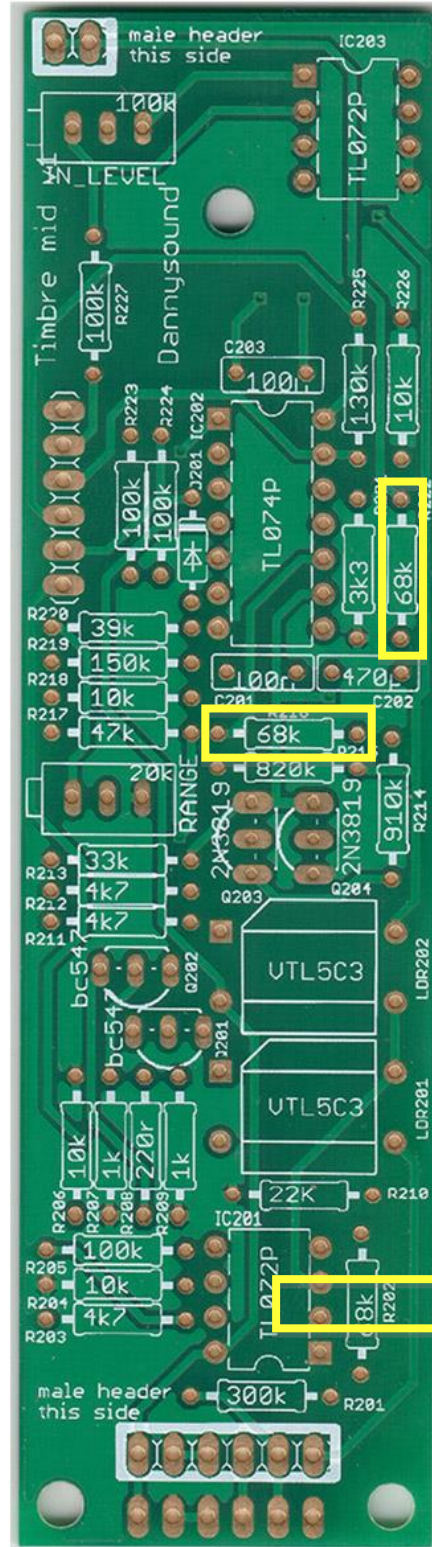

34 - 3 x 68k (R202, R216, R222)

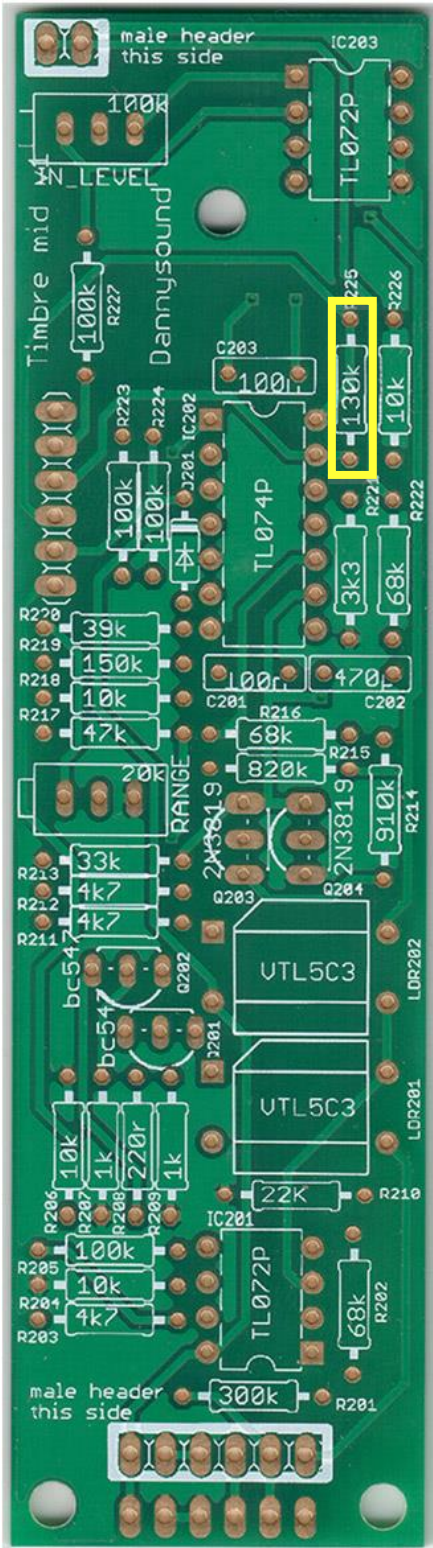

37 - 1 x 130k (R225)

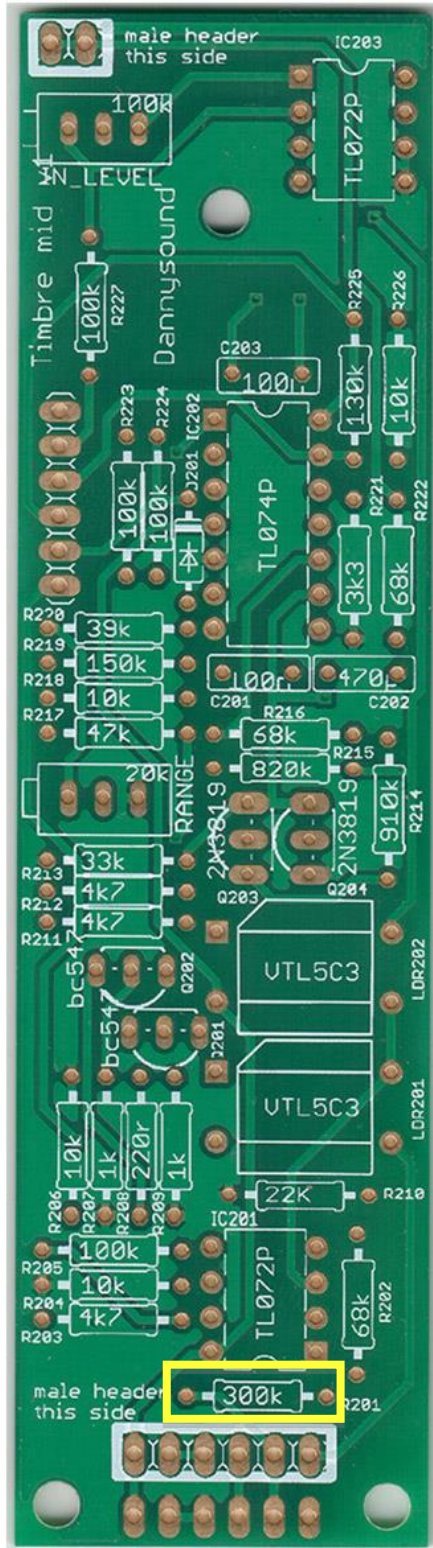

38 - 1 x 300k (R201)

DIODE

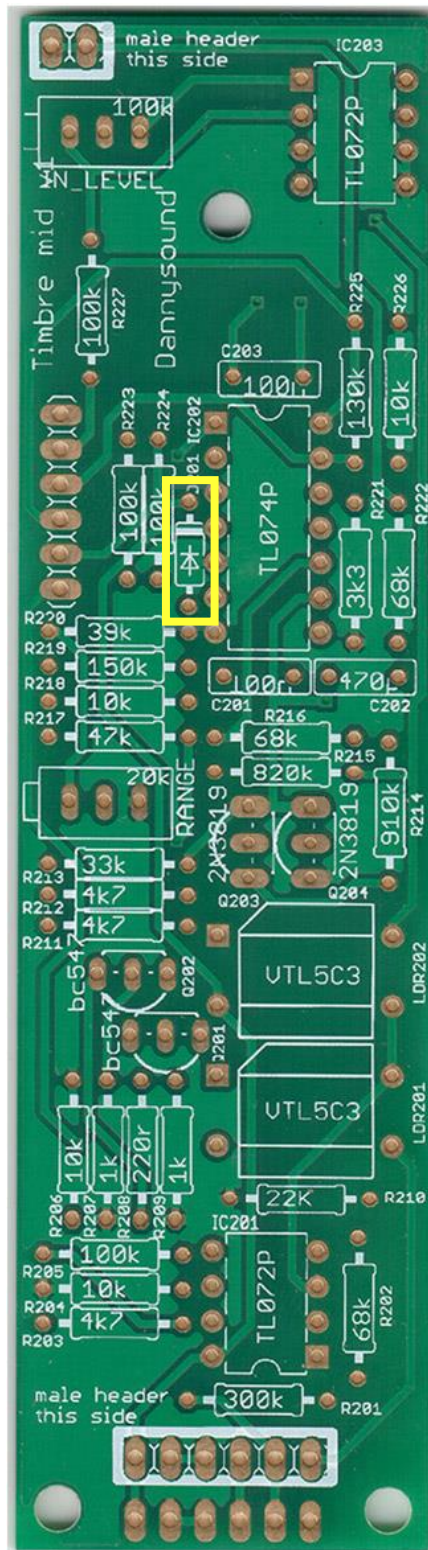

41 - 1 x 1N4148 (D201) **NOTE:** orientation of this part is vital - be sure to match the line on the component with the line on the PCB silkscreen

IC SOCKETS

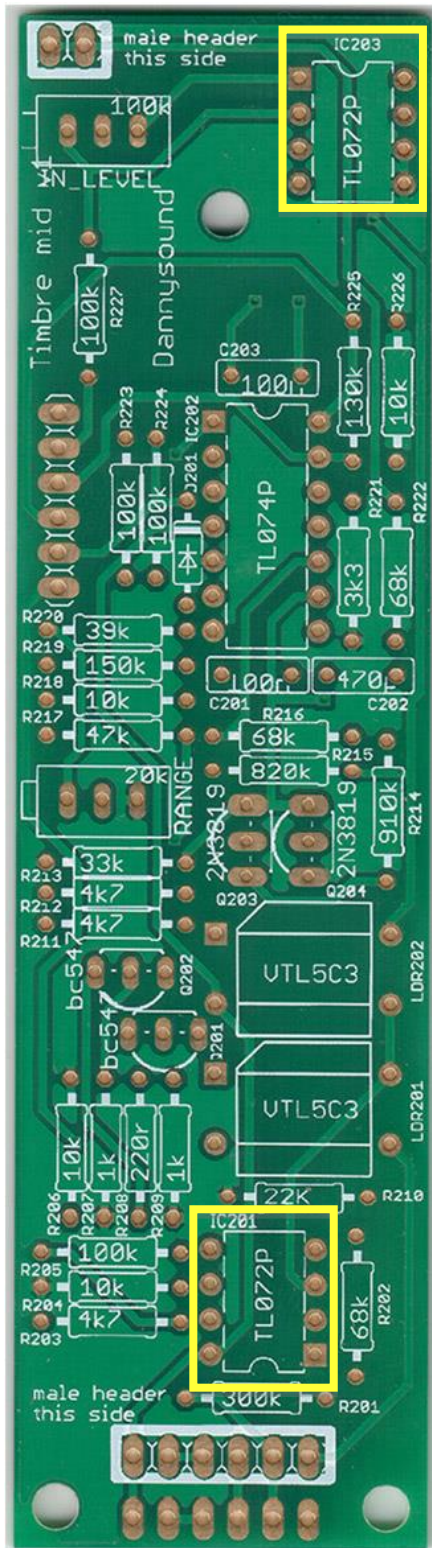

42 - 2 x 8 pin

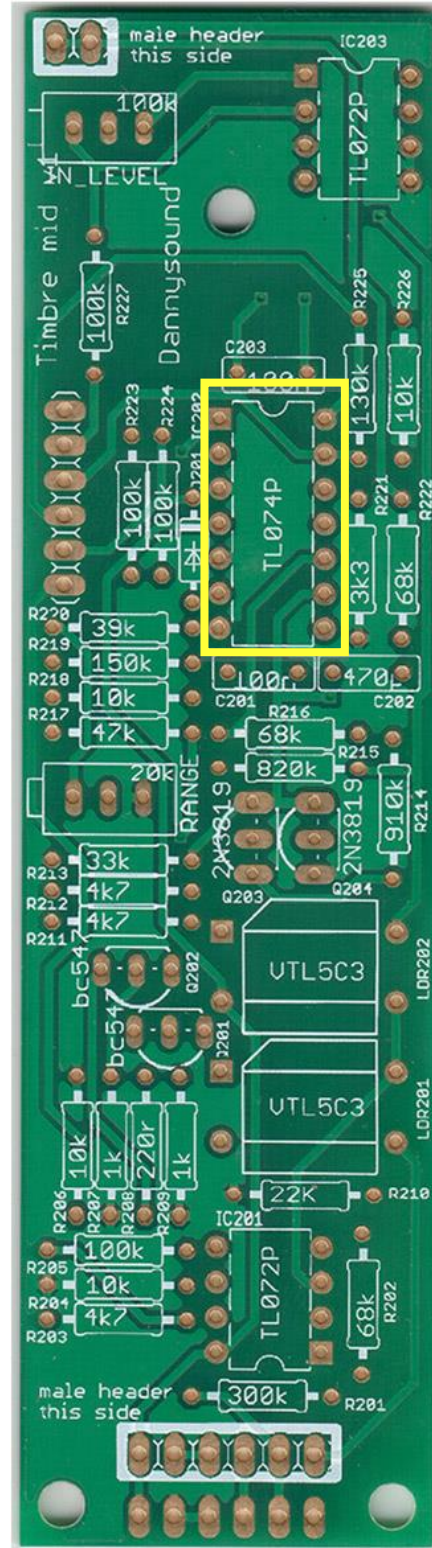

43 - 1 x 14 pin

NOTE: make sure the notches in the sockets match the notches on the PCB silkscreen.

TRIMMERS

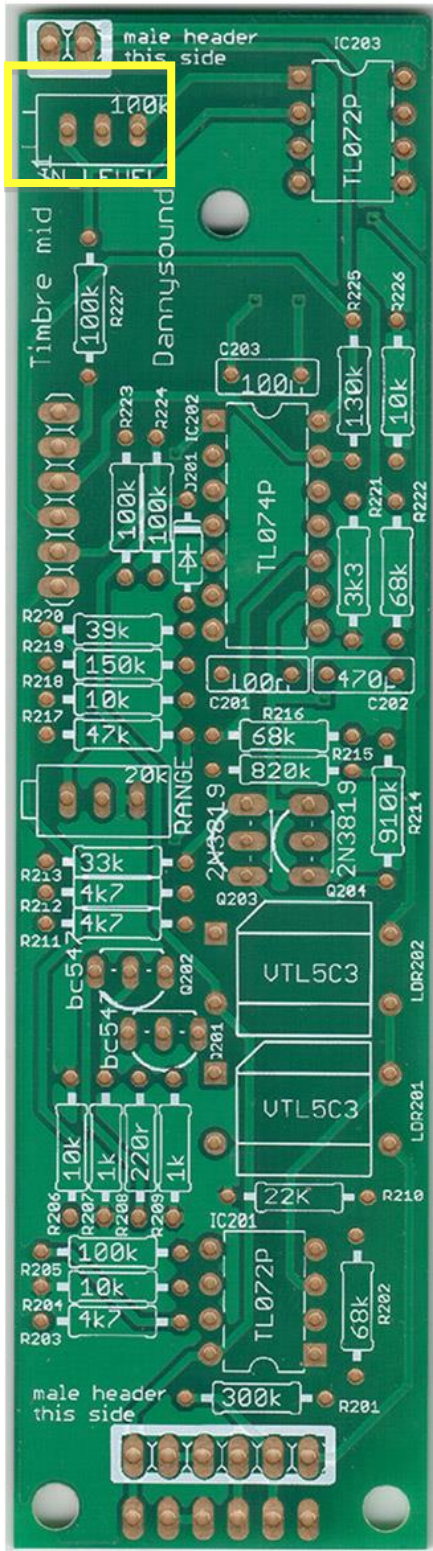

46 - 1 x 100k side adjust trimmer (IN_LEVEL)

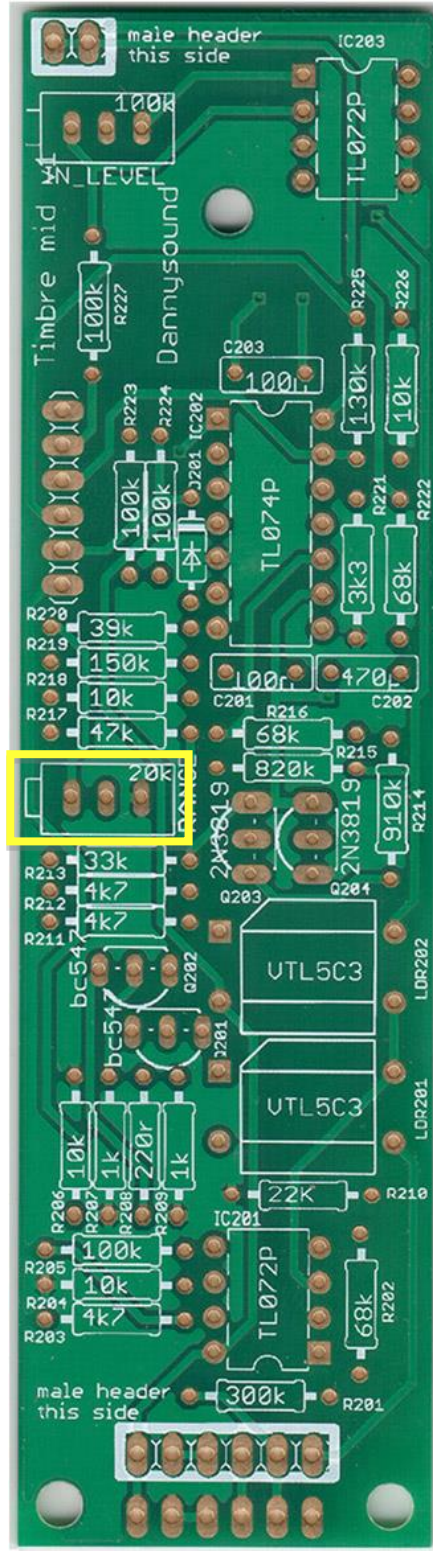

47 - 1 x 20k side adjust trimmer (RANGE)

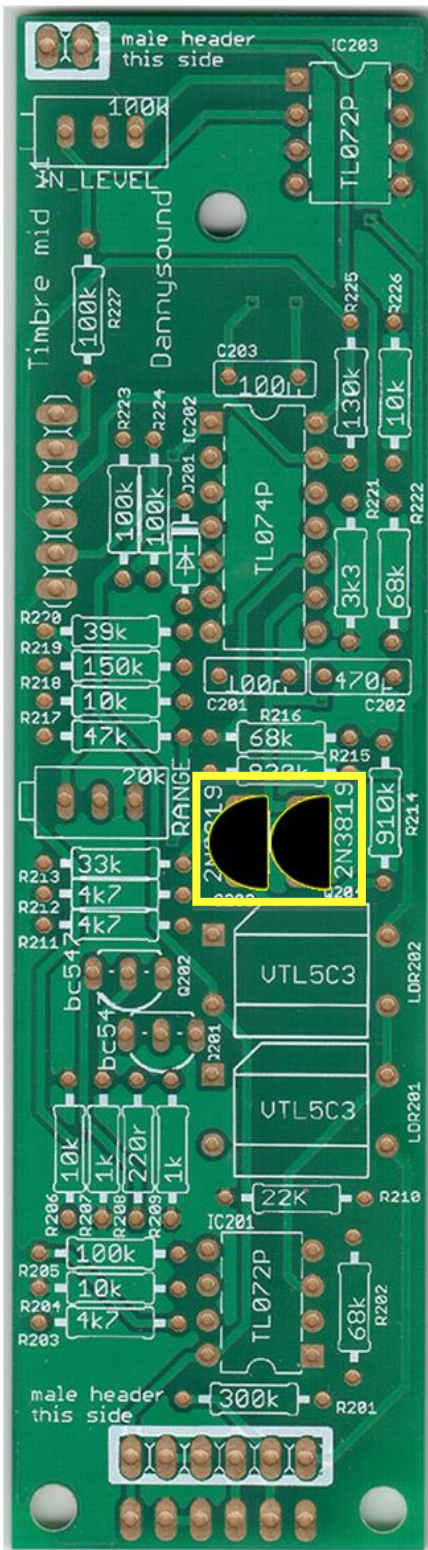

48 - 2 x 2N3819 (Q203, Q204)

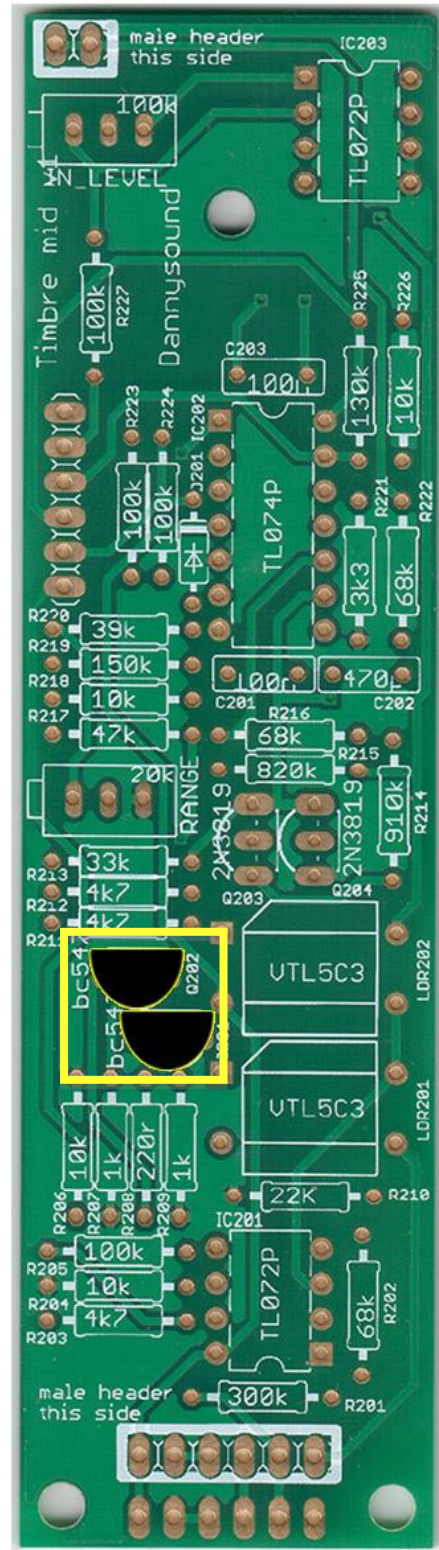

49 - 2 x BC547 (Q201, Q202)

NOTE! Ensure the flat face on the components matches the flat face on the PCB silkscreen. Orientation is vital!

VACTROLS

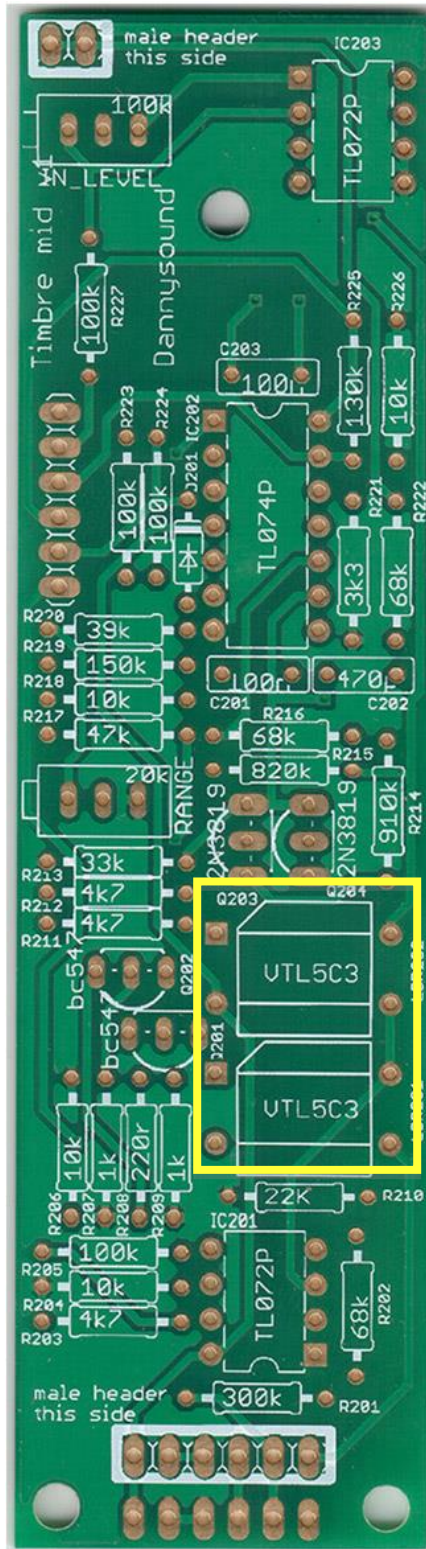

50 - 2 x VTL5C3 Vactrols - Note: orientation matters -the sloped edge of each Vactrol must line up with the sloped edge on the PCB silkscreen.

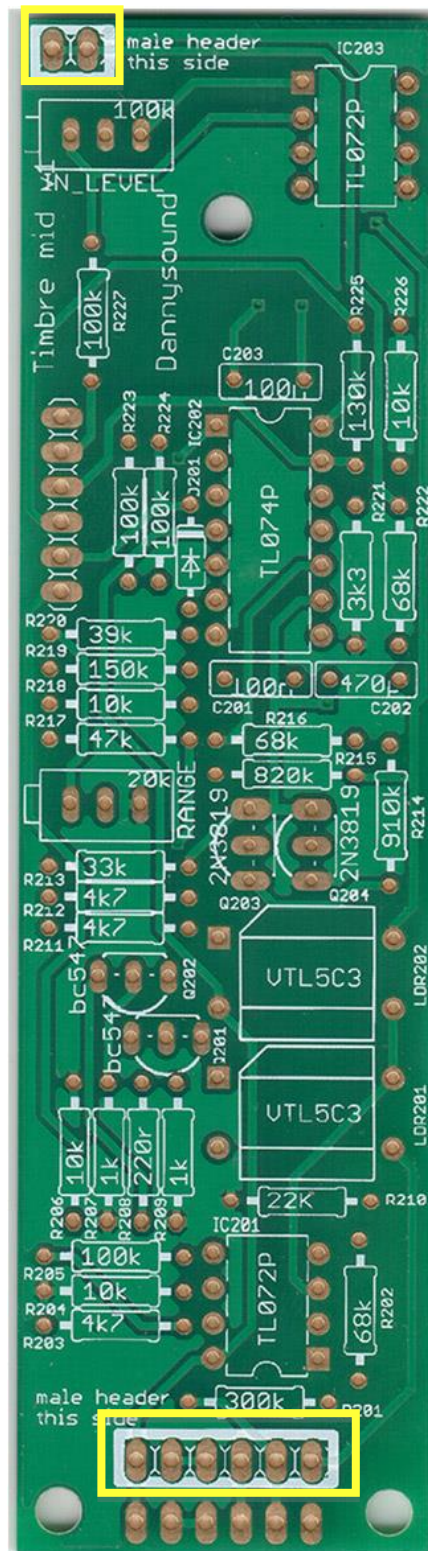

51 - 1x6 pin and 1x2 pin male header - these headers are placed on the same side as the rest of the components on this PCB

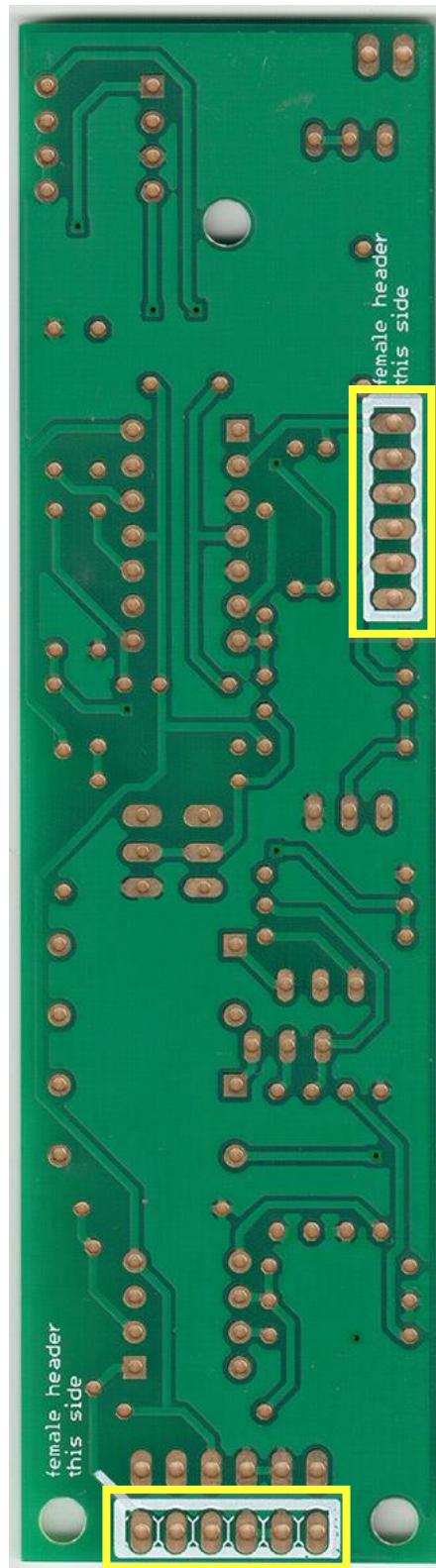

52 - 2 x 1x6 pin female header

NOTE! These headers are placed on the **opposite side** of all the other components on this PCB!

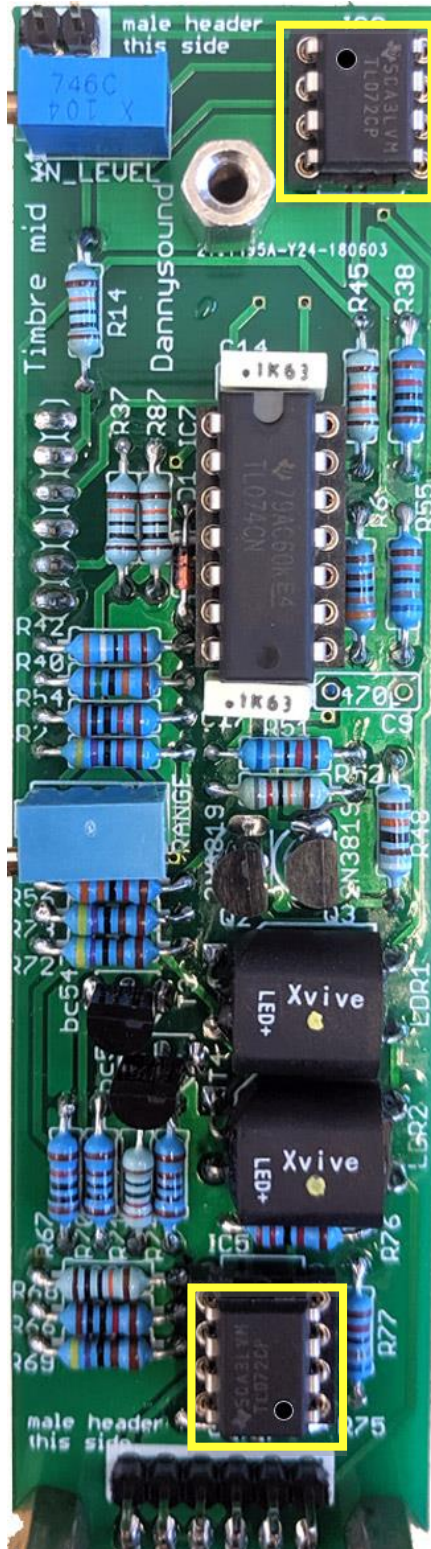

53 - 2 x TL072 opamps - orientation is vital, for these opamps match the dot with the notch on the PCB silkscreen and IC socket

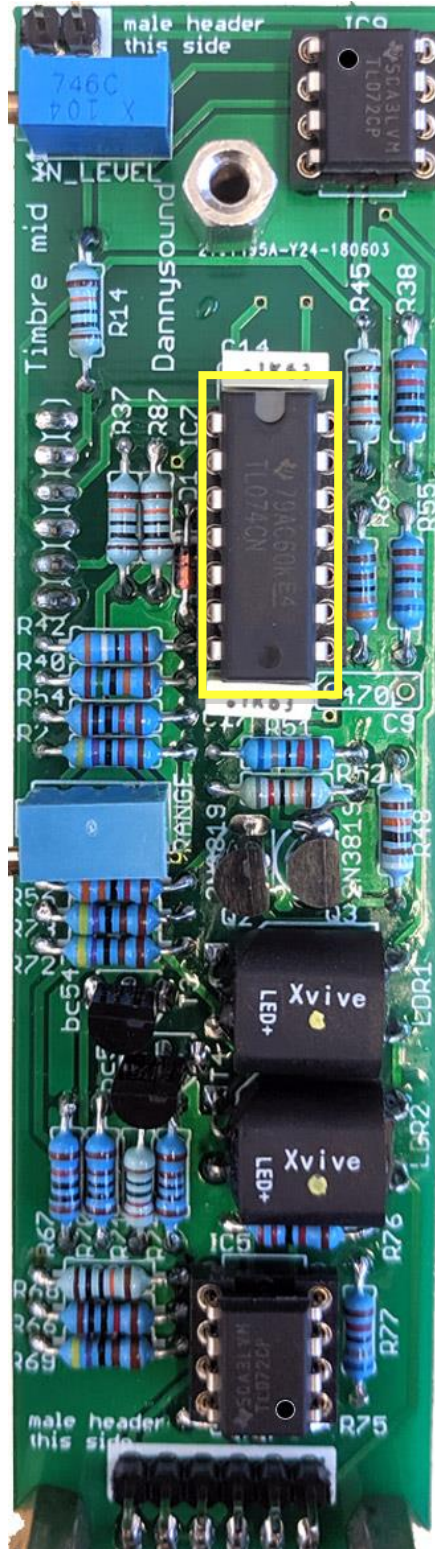

54 - 1 x TL074 opamp - orientation is vital, for this opamp match the notch on the chip with the notch on the PCB silkscreen and IC socket

6 - Pots Board RESISTORS

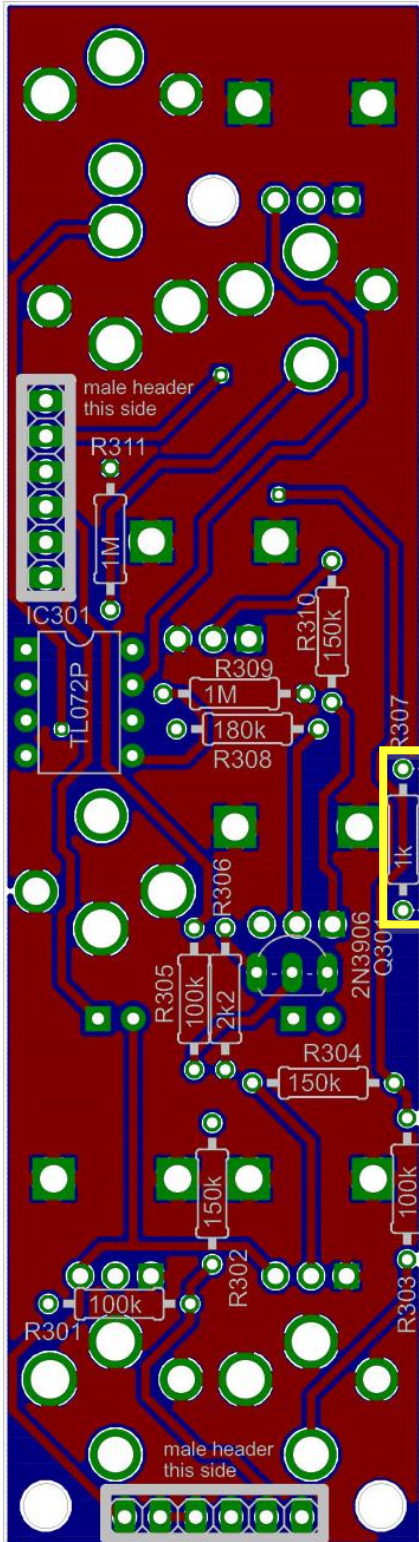

55 - 1 x 1k (R307)

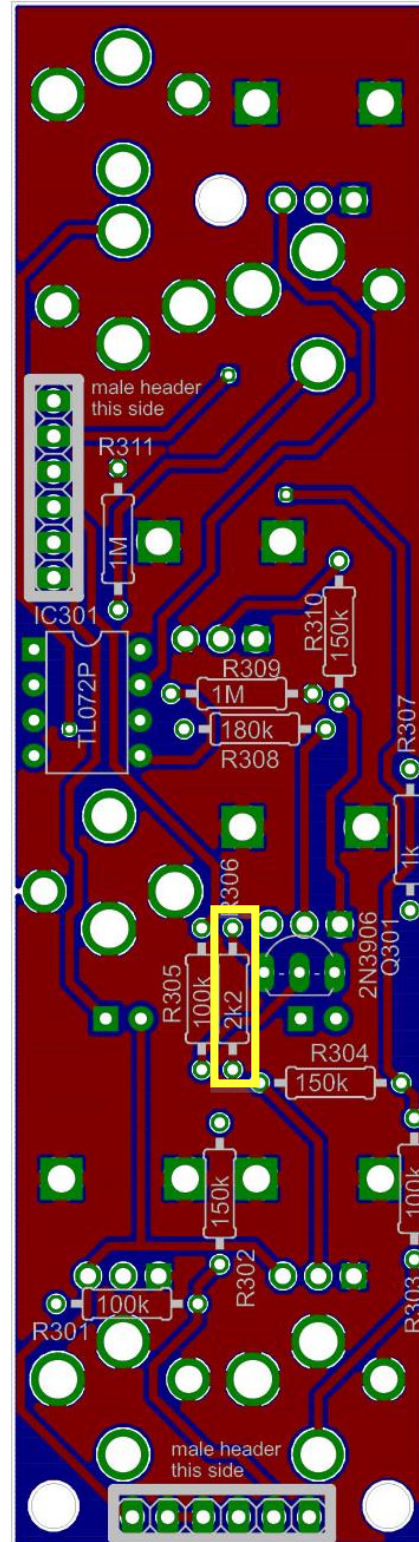

56 - 1 x 2k2 (R306)

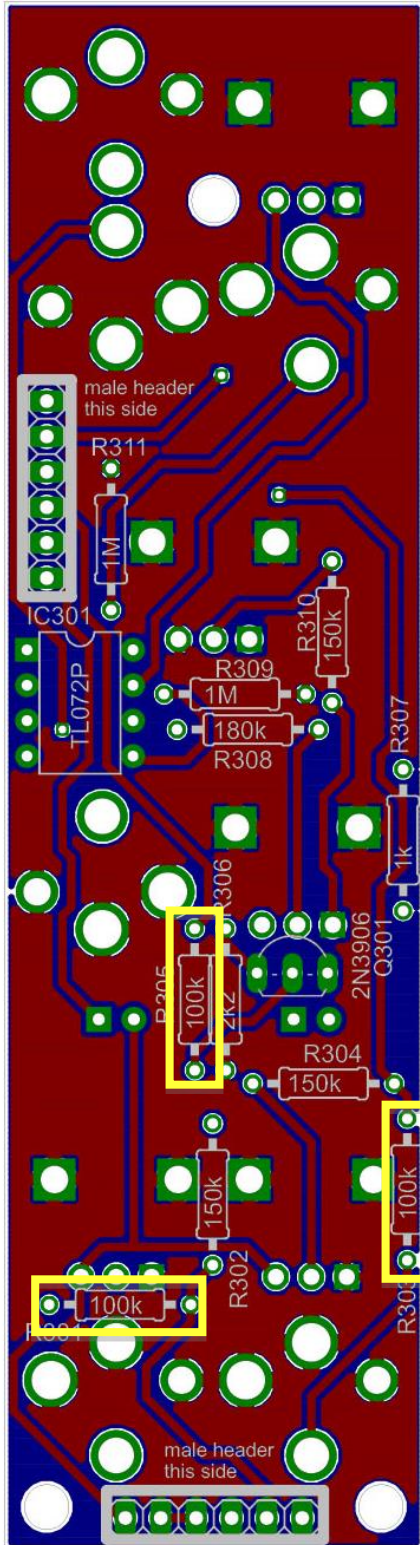

57 - 3 x 100k (R301, R303, R305)

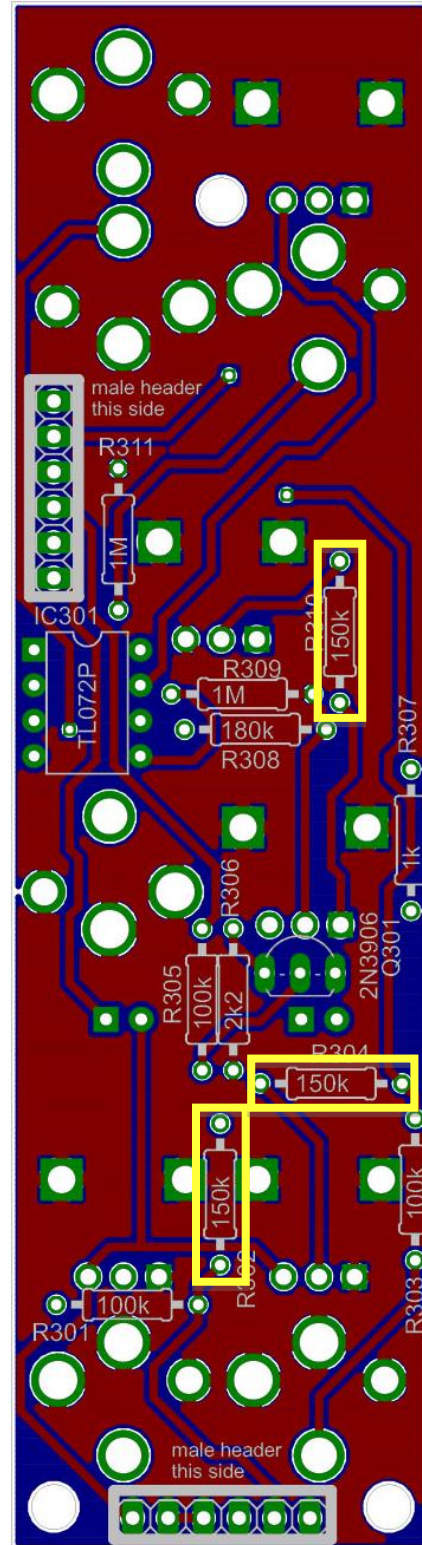

58 - 3 x 150k (R302, 304, 310)

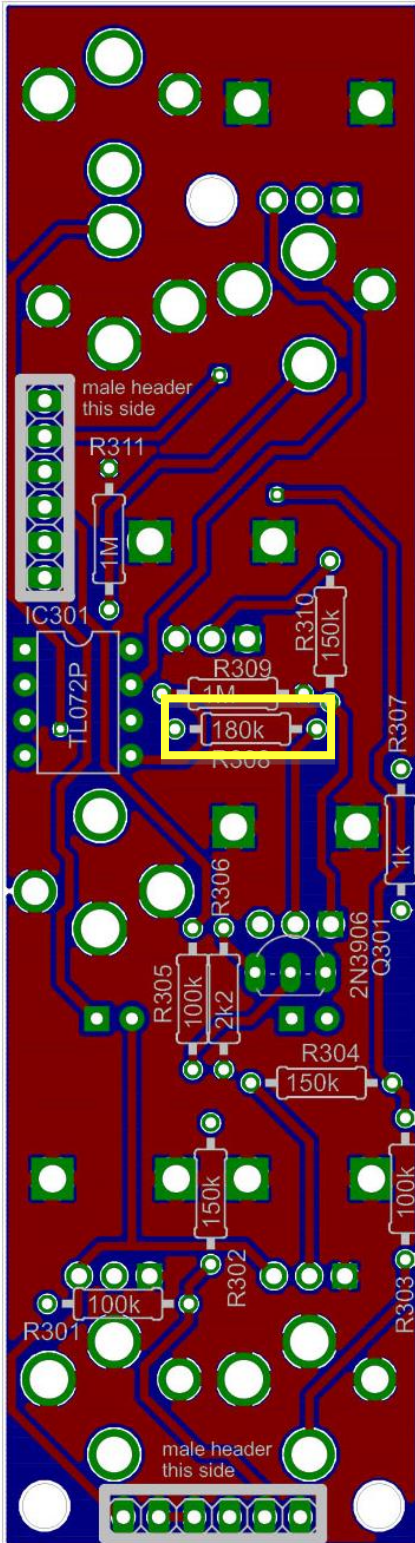

59 - 1 x 180k (R308)

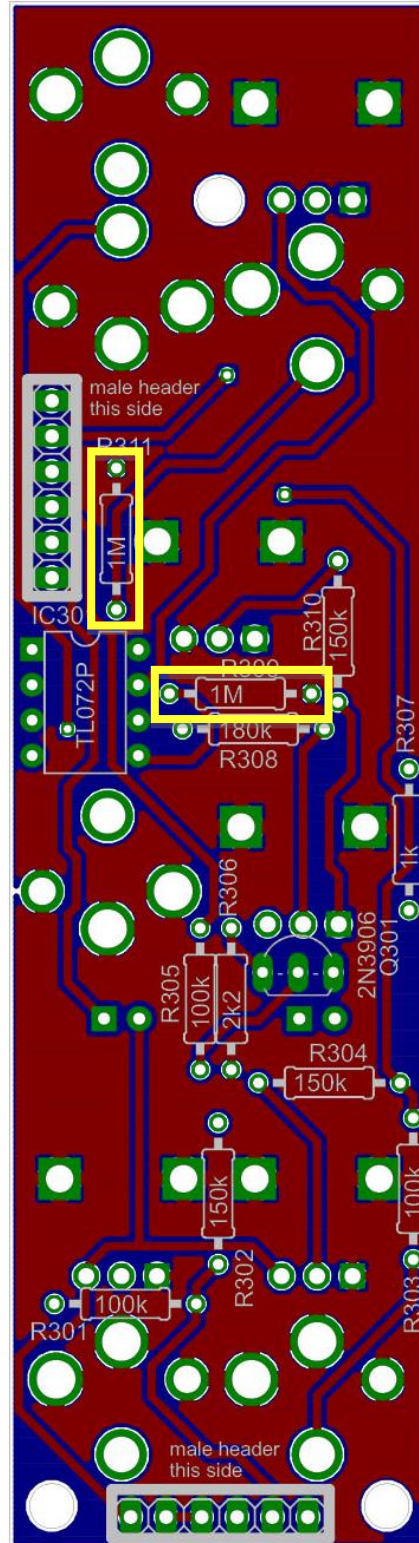

60 - 2 x 1M (R309, R311)

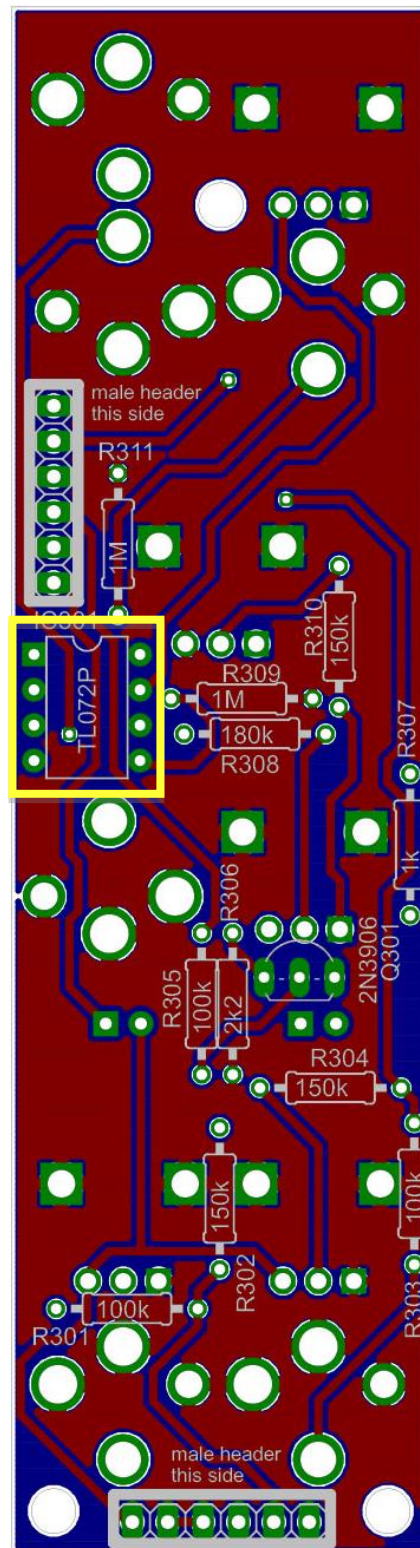

61 - 1 x 8 pin IC socket - make sure the notch in the socket matches the notch on the PCB silkscreen.

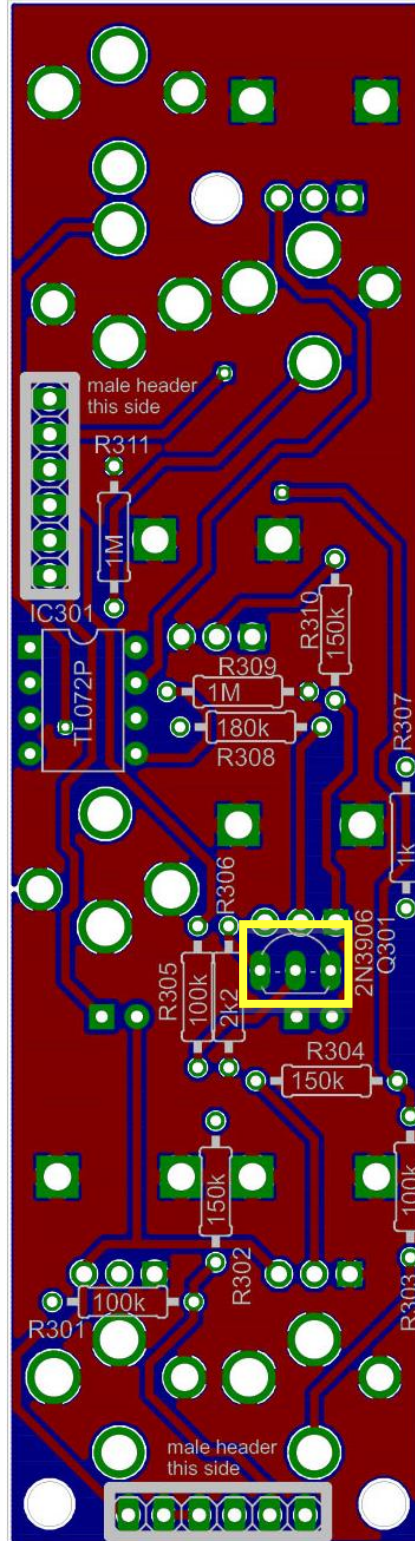

62 - 1 x 2N3906 - **NOTE!** Ensure the flat face on the components matches the flat face on the PCB silkscreen. Orientation is vital!

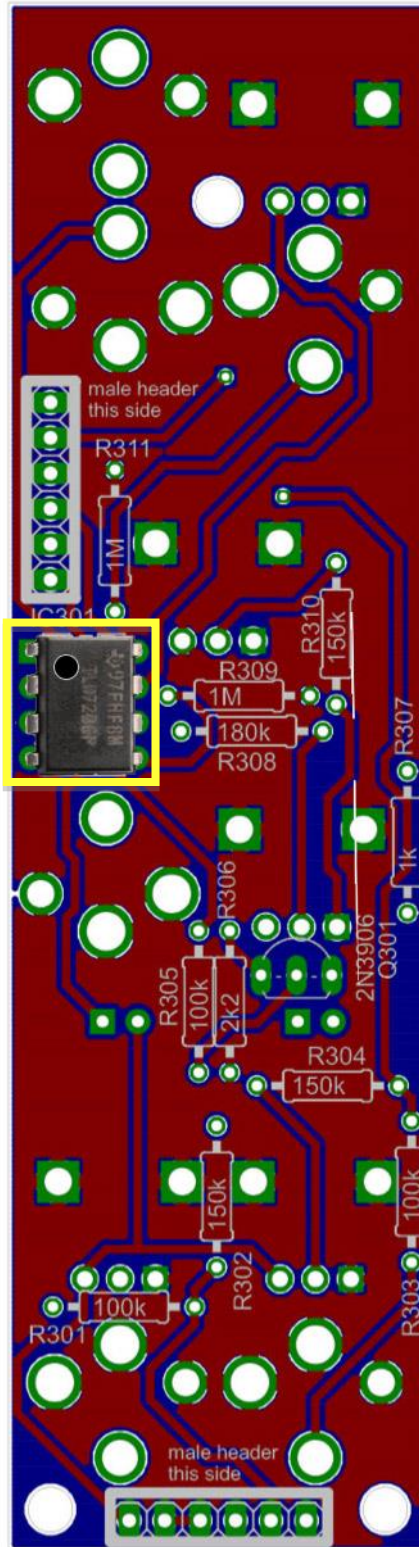

63 - 1 x TL072 opamp - orientation is vital, for this opamp match the dot with the notch on the PCB silkscreen and IC Socket

HEADER

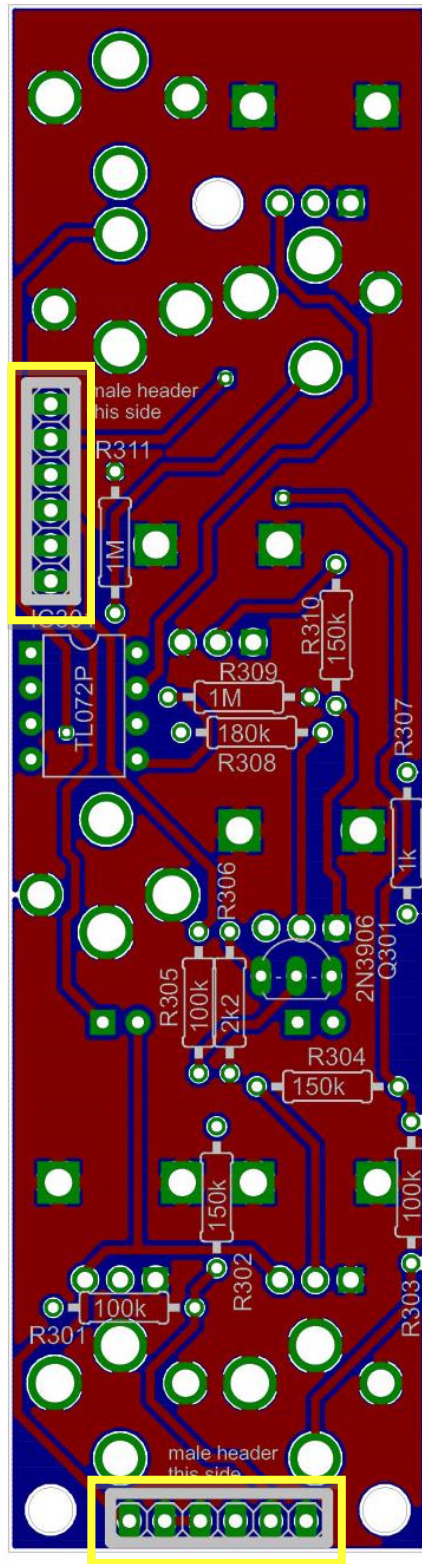

64 - 2 x 1x6 pin male headers - these headers are placed on the same side as the rest of the components already soldered on this PCB

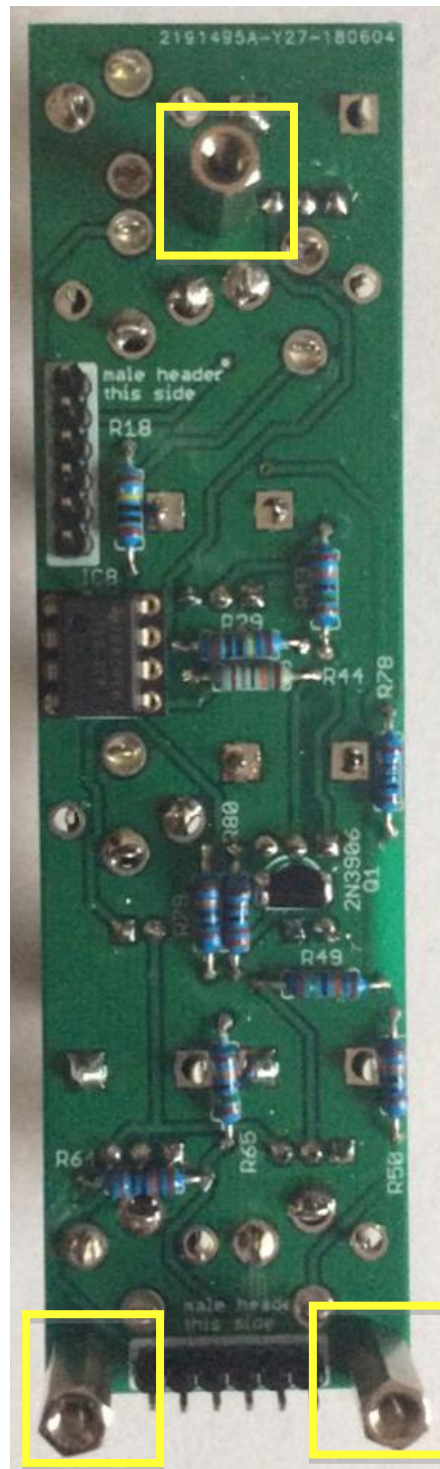

65 - Install the 3 x Female to Female 11mm standoffs to the PCB using supplied screws

7 Panel Components

These components should be inserted but **NOT SOLDERED** until the panel has been placed on top of the PCB. This is to ensure that the PCB fits the panel properly.

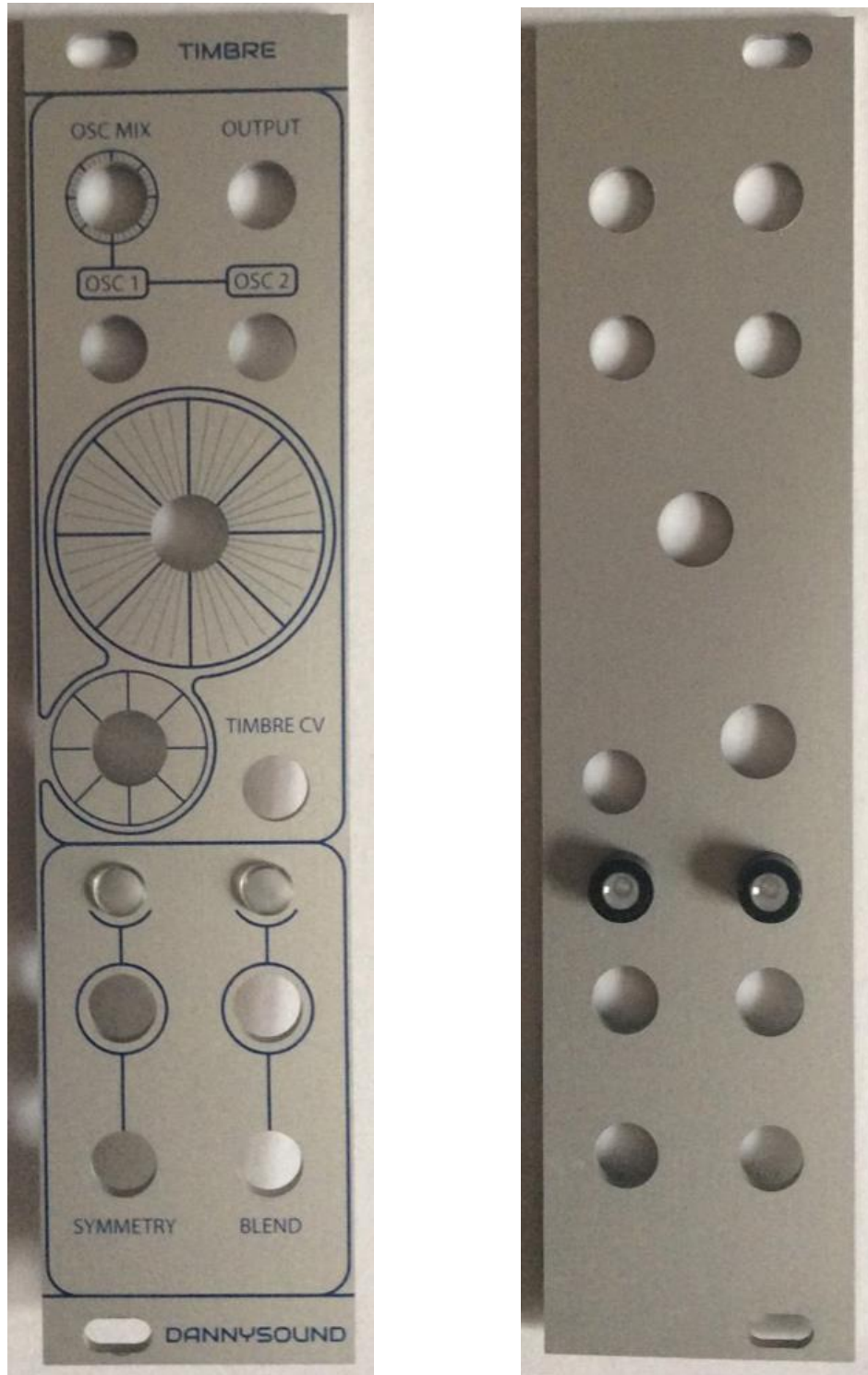

66 - Install the 2 x light pipes and retainer clips

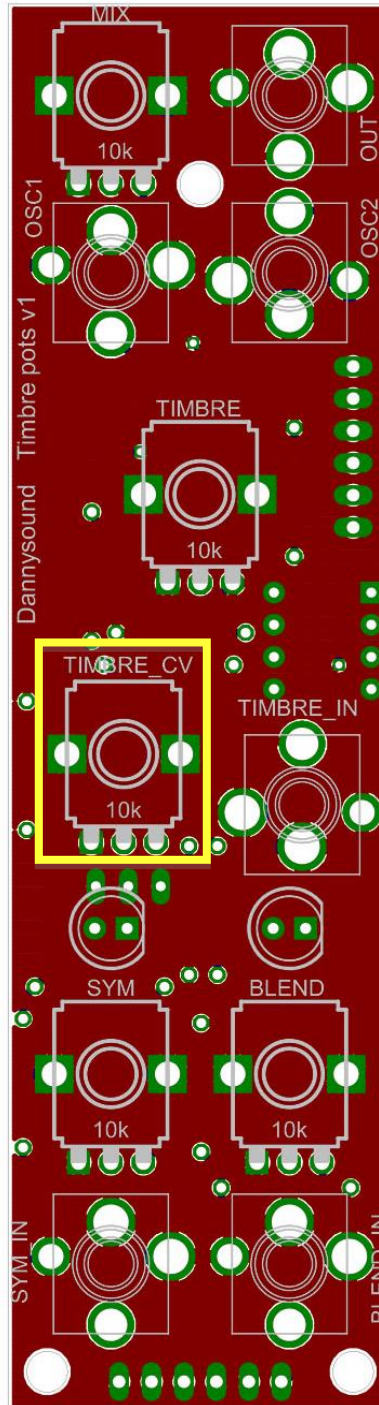

67 - 1 x B10K Centre-Detent Alpha Pot



B10K Centre Detent

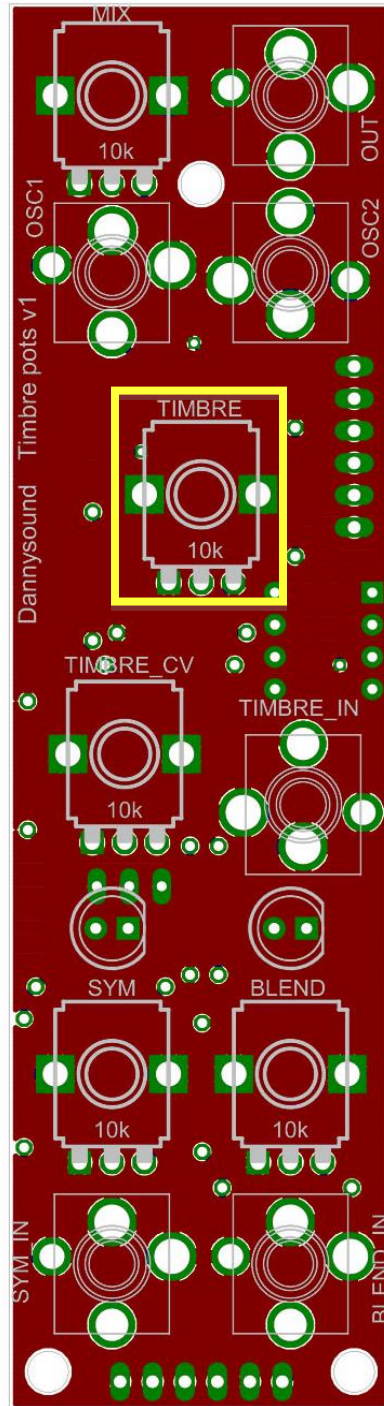

68 - 1 x B10K alpha pot - no detent



B10K

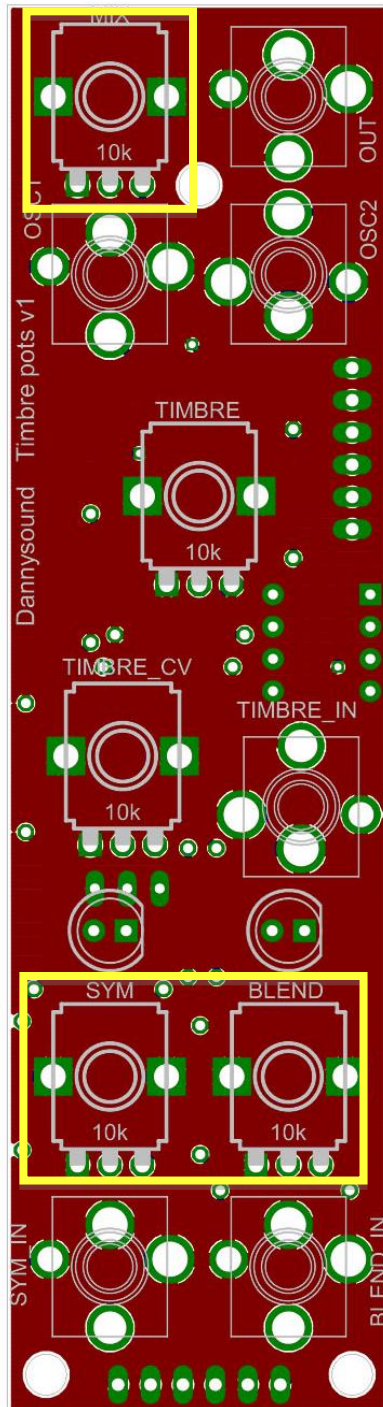

B100K (B104)

69 - 3 x B100k (B104) blue body plastic shaft pots

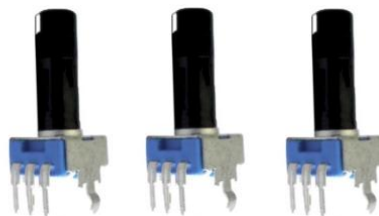

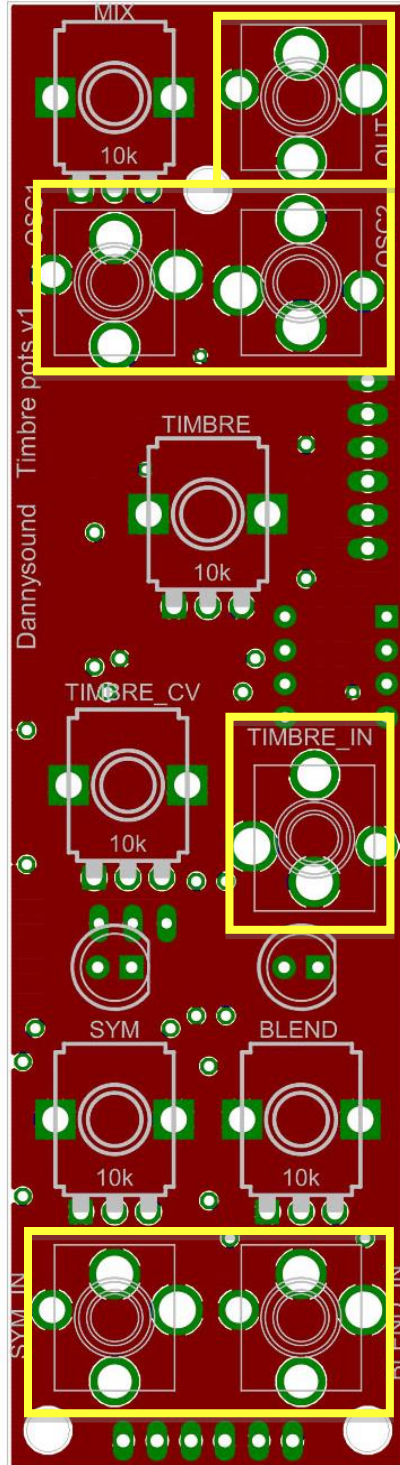

70 - 6 x Jack Sockets (PJ301BM or PJ398S-BM)



71 - 2 x 3mm Red LEDs - **NOTE:** orientation is vital, the shorter leg of the LED should go to the square pad and flat side of the PCB silkscreen diagram.



72 – Fit the panel in place then while holding everything together turn over and solder one pin of the lower symmetry jack socket and one pin of the output jack socket. Ensure these sockets are pressed to the PCB properly (reflow the solder whilst applying pressure to the socket if it's not a snug fit) then attach the 2 knurled nuts as shown above to keep everything in place.

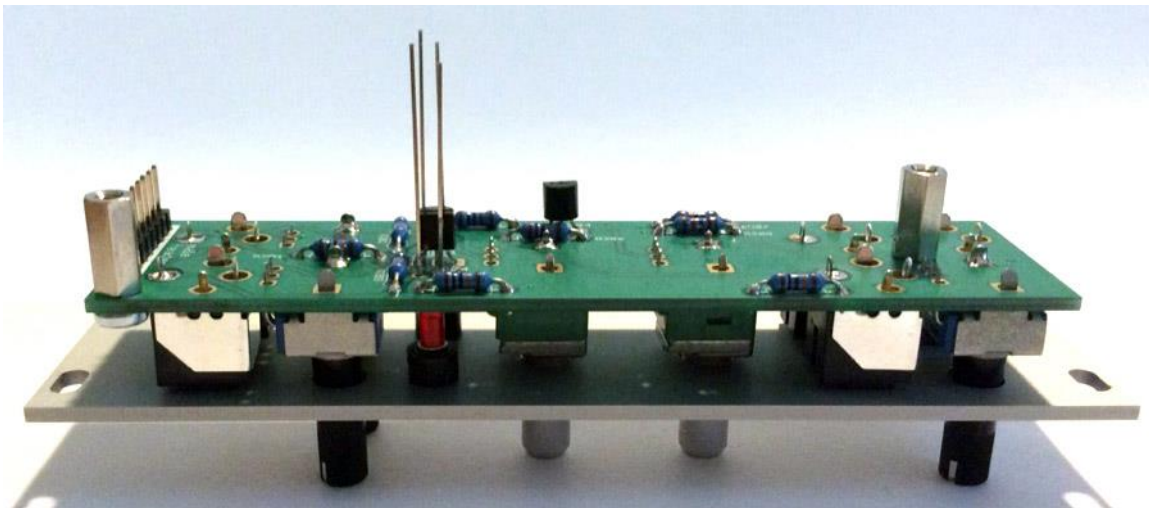
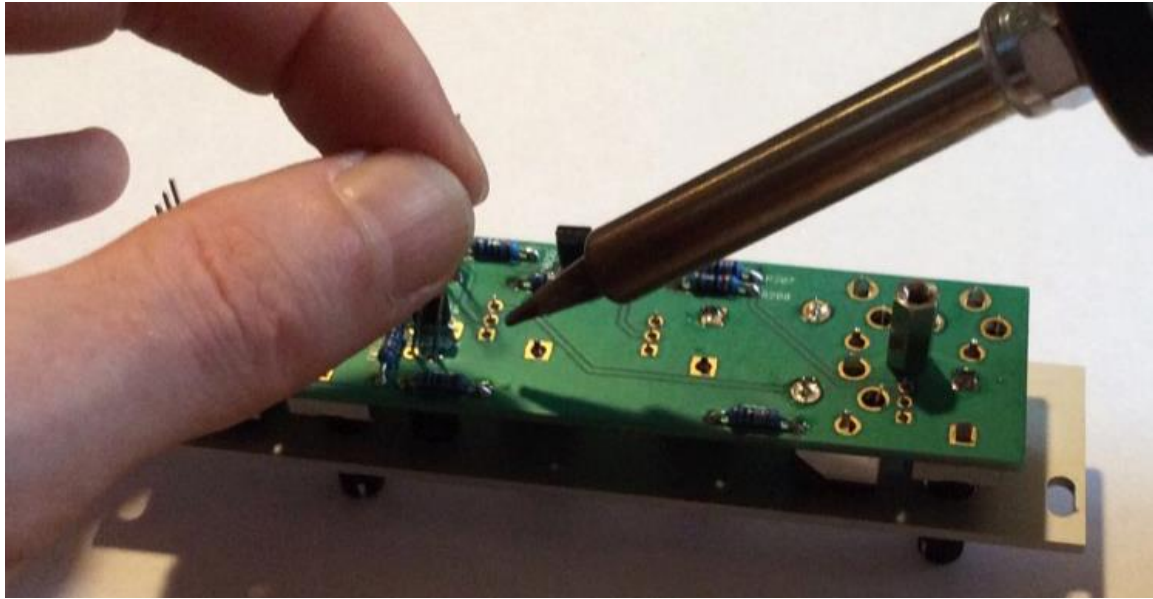

73 - Solder one leg of each of the LEDs, you can then reflow the solder to that pin while holding the LED legs to position it nicely against the light pipes.



74 – Add the knobs then solder one of the ground tabs of each pot (including the tall trimmers). There is a little room for adjustment of the tall trimmers and pots so if they look out of alignment against the graphics or if the tall trimmers slightly rub when turn them you can reflow the solder whilst applying a little pressure to get them positioned perfectly.



75 – Add the rest of the nuts to jack sockets to hold everything together firmly. Once that’s all done and looking good you can solder the rest of the pins of each component.

8 Final Assembly

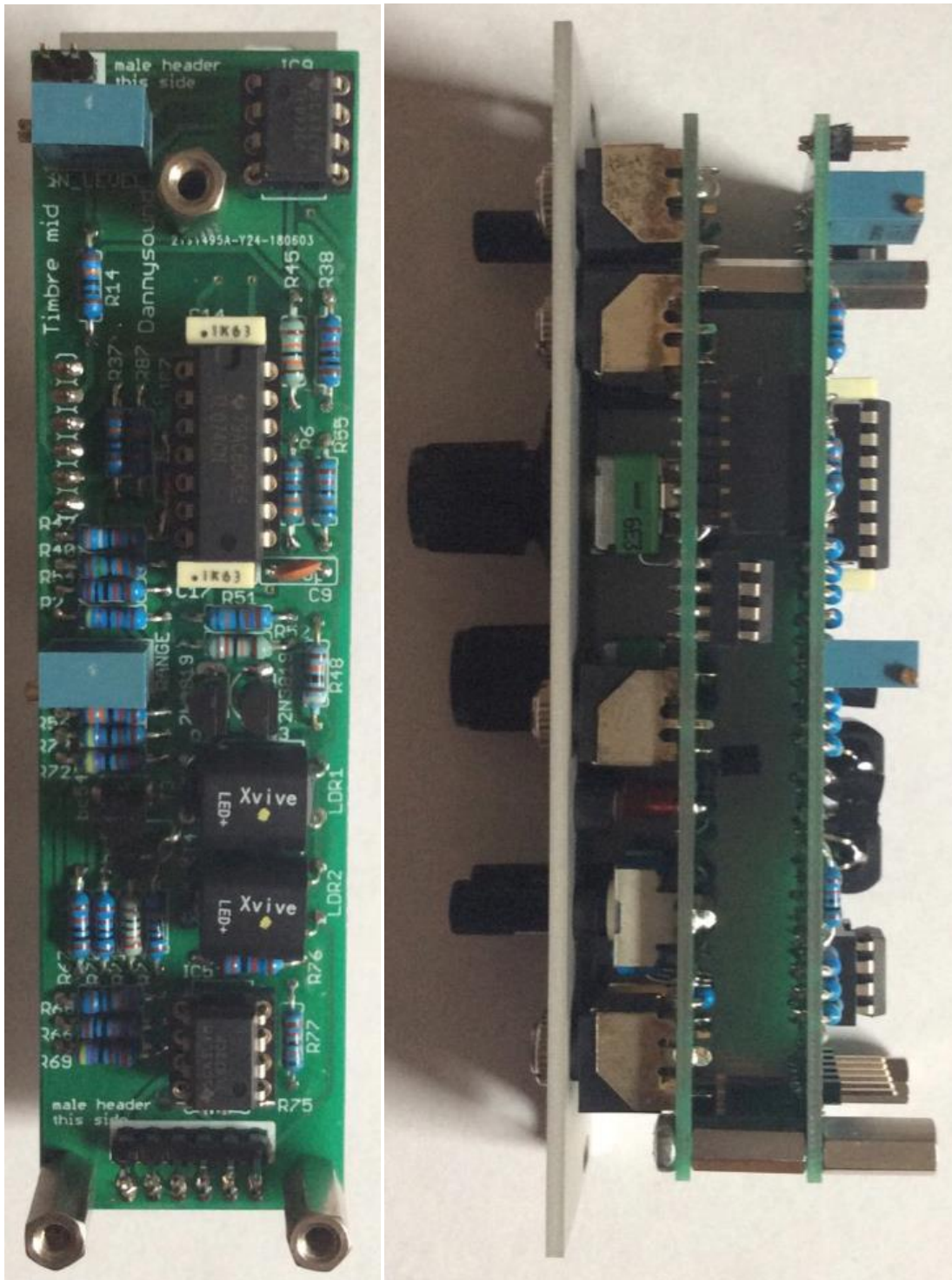

76 - Attach the mid board to the pot board using the 3 x Male to Female 12mm standoffs.

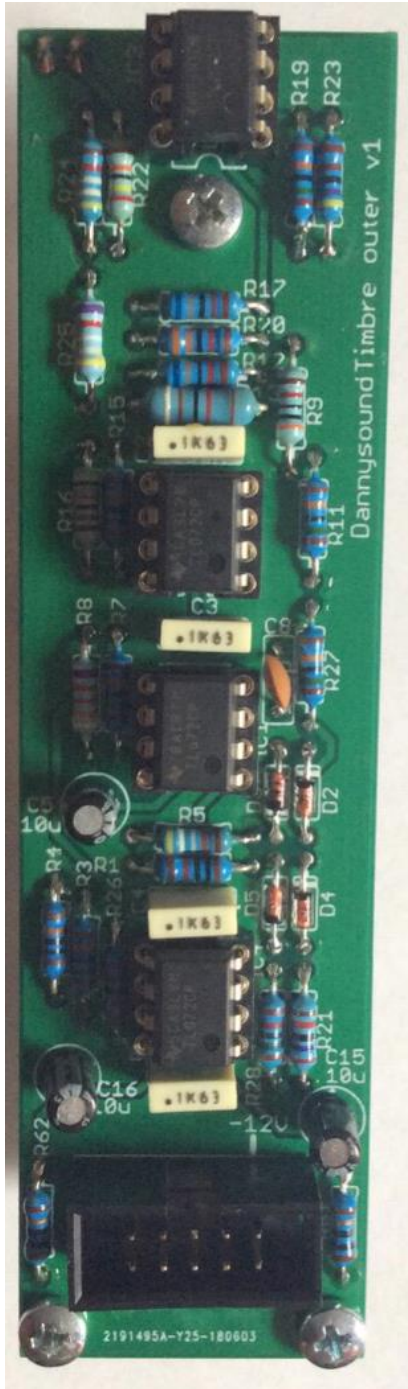

77 - Attach the outer board and screws

9 Testing and Calibration

Calibration is simple and can be done by ear or by computer oscilloscope software that allows you to see the audio waveform in realtime (WaveWindow by RustyKat for the Mac is good, PC users seem to like Soundcard Scope by Zeitnitz). You can also just do it by ear then zoom in on an audio recording on your DAW later to confirm the results. If you have a Eurorack oscilloscope module like the Mordax DATA or Jones O'Tool those can be handy too, but are really not vital at all. Calibrating these modules purely by ear will still get you very good results, it'll just take a little longer.

The first step is to calibrate the IN_LEVEL trimmer so the bypassed level (Blend Control at 0) is the same as the input level.

If you have an amplifier with 2 inputs that will work perfectly for comparing both signals or you can monitor the signals on an oscilloscope.

If you have 2 different amplifiers you can connect the sine or triangle to each amplifier and adjust them to the same volume level.

The following method assumes an amplifier with 2 inputs.

- 1 – Connect a sine or triangle wave to amplifier input 1 AND to the OSC 1 input of the TIMBRE, set the MIX control to OSC 1 (fully CCW).
- 2 – Connect the Timbre Output to amplifier input 2.
- 3 – Set the Blend control to 0.
- 4 – Adjust the IN_LEVEL trimmer so both channel 1 and channel 2 are the same volume level.

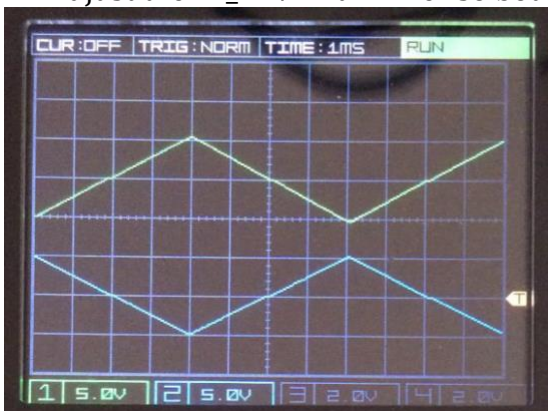

- 5 – Turn the BLEND Control to 100%, set the TIMBRE Control to 0 and set the SYMMETRY Control to 0.

6 – Adjust the RANGE trimmer so the output is a clean sine or triangle wave. If the output is already a clean sine or triangle, adjust RANGE until you hear some higher harmonics start to appear in the waveform then adjust it back to the point where the harmonics just disappear.

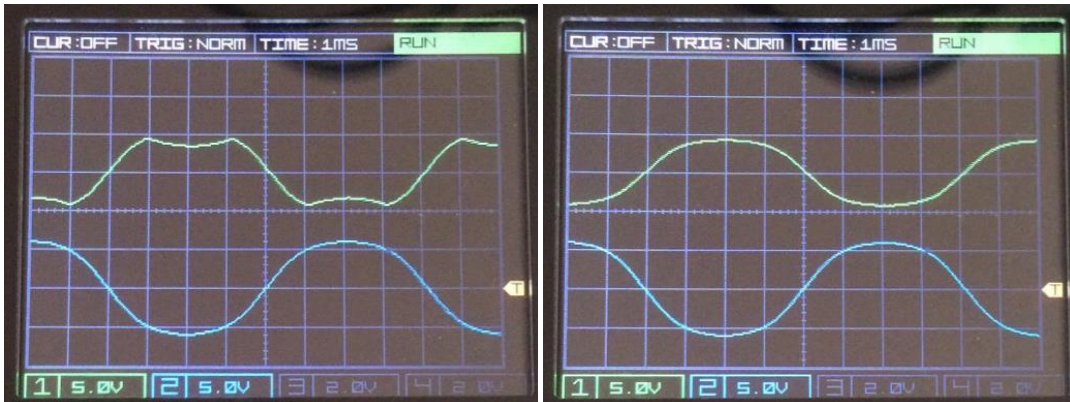

7 – Set SYMMETRY to 100% and listen to the output. You should hear the signal sounds like it's producing an octave up effect. This is a subtle effect!

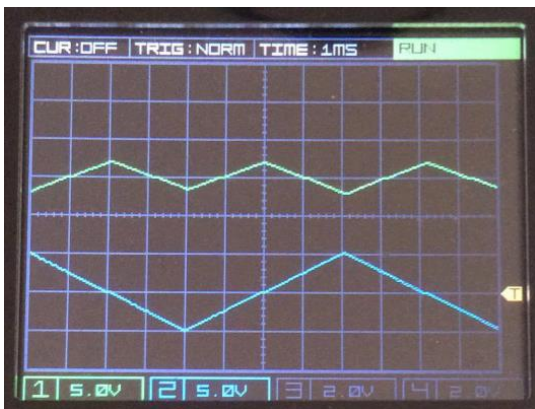

8 – Set SYMMETRY to 0 and set TIMBRE to 100%, you should hear the wave folding adding harmonics to the signal.

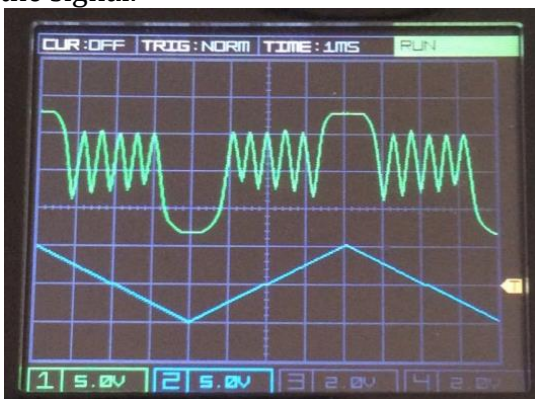

9 – Set TIMBRE to 50%, connect an LFO to the TIMBRE CV input and adjust to 100% or to 0. You should hear the TIMBRE being modulated by the LFO.

10 – Connect a second oscillator to OSC 2 input and set the MIX to 50%, you should hear the output producing extra harmonics on the mix of both oscillators.

10 Modifications

Further adjustments!

The IN_LEVEL trimmer is there to increase the amount of the fundamental against the folded wave when the BLEND control is modulated or set to some position other than full.

Increasing the IN_LEVEL trimmer requires re-adjusting the RANGE trimmer so that the output is still a clean sine or triangle wave when the TIMBRE and SYMMETRY controls are at 0.

This is down to the users preference. The recommendation is to give the fundamental a slight boost to about $\pm 6V$ from a $\pm 5V$ source. This does reduce the range of the TIMBRE control a little at its highest setting but it makes for a more balanced tone in operation.

Changing R308 from 180k down to around 100k will increase the range of the TIMBRE CV.

Changing R214 from 910k down to around 100k will increase the range of the SYMMETRY Control and CV. The change to R214 gives the SYMMETRY control a much more pronounced effect.

The recommended settings are:

R308 – 120k

R214 – 150k